

# Model 3950 and 3951

Forma 29 cu. ft. Reach-In Incubator

Operating and Maintenance Manual 7003950 Rev. 21



Visit us online to register your warranty  
[www.thermoscientific.com/labwarranty](http://www.thermoscientific.com/labwarranty)

**Thermo**  
SCIENTIFIC

Covered Models	CO <sub>2</sub> Sensor*	Voltage**
3950	T/C	100-120
3951	T/C	200-230

\* T/C is a thermal conductivity sensor.

\*\* All units are 50/60 Hz.

### Manual Number 7003950

21	29318//IN-4272	12/14/12	Clarified usage on exploded drawing 3950-08-4 list	ccs
20	28773//IN-4231	10/8/12	Updated Figure 1-6 to current	ccs
19	28267	2/20/12	Added cautions for running high RH or temps	ccs
18	24921//IN-3939	2/16/12	Removed accessory list - pg 7-2	ccs
17	27292//IN-4073	9/29/11	Updated component mount assy drawing - spacers (pg 8-7 & 8-8)	ccs
16	27398//IN-4107	9/13/11	Updated float sw 360171 to 1900471 assy with pins 370397 - pg 8-1	ccs
15	25421//IN-3917	3/25/09	Corrected Mode Menu list pg 1-3	ccs
14	24975	10/31/08	Updated water specs on page 1-6	ccs



**Important** Read this instruction manual. Failure to read, understand and follow the instructions in this manual may result in damage to the unit, injury to operating personnel, and poor equipment performance. ▲

**Caution** All internal adjustments and maintenance must be performed by qualified service personnel. ▲

**Warning** If the incubator is not used in the manner specified in this operating manual, the protection provided by the equipment design may be impaired. ▲

**Caution** When operating this unit under high temperatures and/or relative humidity (RH), caution must be observed when the unit is shut down, unexpectedly or by choice. Condensate can form on the interior of the chamber as it cools. This includes the heating element surfaces. Heavy condensate can bridge the ceramic insulators and cause a temporary electrical short to ground. This electrical circuit is protected by a circuit breaker. However, to avoid this contingency if these conditions occur, open the door of the unit and allow it to stand open until the water vapor disperses. ▲

Material in this manual is for information purposes only. The contents and the product it describes are subject to change without notice. Thermo Fisher Scientific makes no representations or warranties with respect to this manual. In no event shall Thermo be held liable for any damages, direct or incidental, arising out of or related to the use of this manual.

©2000 Thermo Fisher Scientific. All rights reserved.



Important operating and/or maintenance instructions. Read the accompanying text carefully.



Potential electrical hazards. Only qualified persons should perform procedures associated with this symbol.



Equipment being maintained or serviced must be turned off and locked off to prevent possible injury.



Hot surface(s) present which may cause burns to unprotected skin, or to materials which may be damaged by elevated temperatures.



Marking of electrical and electronic equipment, which applies to electrical and electronic equipment falling under the Directive 2002/96/EC (WEEE) and the equipment that has been put on the market after 13 August 2005.



This product is required to comply with the European Union's Waste Electrical & Electronic Equipment (WEEE) Directive 2002/96/EC. It is marked with the WEEE symbol. Thermo Fisher Scientific has contracted with one or more recycling/disposal companies in each EU Member State European Country, and this product should be disposed of or recycled through them. Further information on Thermo's compliance with this directive, the recyclers in your country and information on Thermo Scientific products will be available at [www.thermofisher.com](http://www.thermofisher.com).

- ✓ Always use the proper protective equipment (clothing, gloves, goggles, etc.)
- ✓ Always dissipate extreme cold or heat and wear protective clothing.
- ✓ Always follow good hygiene practices.
- ✓ Each individual is responsible for his or her own safety.

## Do You Need Information or Assistance on Thermo Scientific Products?

If you do, please contact us 8:00 a.m. to 6:00 p.m. (Eastern Time) at:

1-740-373-4763

1-800-438-4851

1-877-213-8051

<http://www.thermoscientific.com>

[service.led.marietta@thermofisher.com](mailto:service.led.marietta@thermofisher.com)

[www.unitylabservices.com](http://www.unitylabservices.com)

Direct

Toll Free, U.S. and Canada

FAX

Internet Worldwide Web Home Page

Tech Support Email Address

Certified Service Web Page

Our **Sales Support** staff can provide information on pricing and give you quotations. We can take your order and provide delivery information on major equipment items or make arrangements to have your local sales representative contact you. Our products are listed on the Internet and we can be contacted through our Internet home page.

Our **Service Support** staff can supply technical information about proper setup, operation or troubleshooting of your equipment. We can fill your needs for spare or replacement parts or provide you with on-site service. We can also provide you with a quotation on our Extended Warranty for your Thermo Scientific products.

Whatever Thermo Scientific products you need or use, we will be happy to discuss your applications. If you are experiencing technical problems, working together, we will help you locate the problem and, chances are, correct it yourself...over the telephone without a service call.

When more extensive service is necessary, we will assist you with direct factory trained technicians or a qualified service organization for on-the-spot repair. If your service need is covered by the warranty, we will arrange for the unit to be repaired at our expense and to your satisfaction.

Regardless of your needs, our professional telephone technicians are available to assist you Monday through Friday from 8:00 a.m. to 6:00 p.m. Eastern Time. Please contact us by telephone or fax. If you wish to write, our mailing address is:

Thermo Fisher Scientific  
401 Millcreek Road, Box 649  
Marietta, OH 45750

International customers, please contact your local Thermo Scientific distributor.

## Warranty Notes

### Information You Should Know Before Requesting Warranty Service

- **Locate the model and serial numbers.** A serial tag is located on the unit itself.
- For equipment service or maintenance, or with technical or special application inquiries, contact Technical Services at 1-800-438-4851 or 1-740-373-4763 (USA and Canada). Outside the USA, contact your local distributor.

### Repairs NOT Covered Under Warranty

- **Calibration of control parameters.** Nominal calibrations are performed at the factory; typically  $\pm 1^{\circ}\text{C}$  for temperature,  $\pm 1\%$  for gases, and  $\pm 5\%$  for humidity. Our service personnel can provide precise calibrations as a billable service at your location. Calibration after a warranty repair is covered under the warranty.
- **Damage resulting from use of improper quality water, chemicals or cleaning agents detrimental to equipment materials.**
- **Service calls for improper installation or operating instructions.** Corrections to any of the following are billable services:
  - 1) electrical service connection
  - 2) tubing connections
  - 3) gas regulators
  - 4) gas tanks
  - 5) unit leveling
  - 6) room ventilation
  - 7) adverse ambient temperature fluctuations
  - 8) any repair external to the unit
- **Damage resulting from accident, alteration, misuse, abuse, fire, flood, acts of God, or improper installation.**
- **Repairs to parts or systems resulting from unauthorized unit modifications.**
- **Any labor costs other than that specified during the parts and labor warranty period, which may include additional warranty on CO<sub>2</sub> sensors, blower motors, water jackets, etc.**



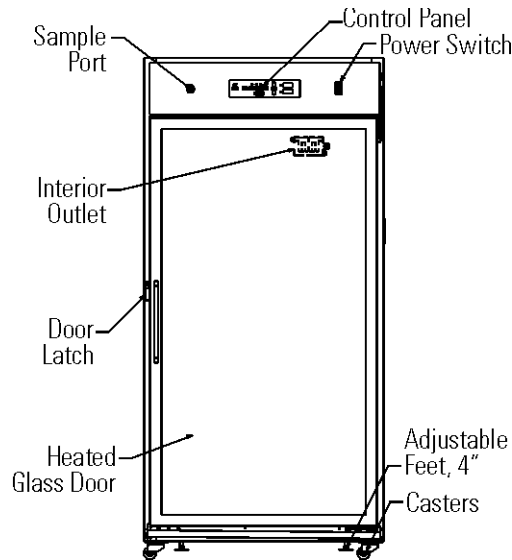
# Table of Contents

<b>Section 1</b>	<b>Installation and Start-Up</b> .....	<b>1-1</b>
	Control Panel Keys, Displays, & Indicators .....	1-2
	Keypad Operation .....	1-3
	Unit Installation .....	1-4
	Preliminary Cleaning and Disinfecting .....	1-4
	Installing the Shelves .....	1-5
	Leveling the Unit .....	1-5
	Attaching the Drain Lines .....	1-5
	The Water Supply .....	1-6
	Filling the Humidity Reservoir .....	1-6
	Connecting the Unit to Electrical Power .....	1-7
	Connecting the CO <sub>2</sub> Gas Supply .....	1-8
	Incubator Start-Up .....	1-9
	Setting the Operating Temperature .....	1-9
	Setting the Overtemp Setpoint .....	1-10
	Setting the CO <sub>2</sub> Setpoint .....	1-10
<b>Section 2</b>	<b>Calibration</b> .....	<b>2-1</b>
	Calibrating the Temperature .....	2-1
	Calibrating the CO <sub>2</sub> System .....	2-2
<b>Section 3</b>	<b>Configuration</b> .....	<b>3-1</b>
	Disable the ADD WATER Alarm .....	3-1
	Turn All Audible Alarms ON/OFF .....	3-1
	Set an Access Code .....	3-2
	Set a Low Temp Alarm Limit .....	3-2
	Enable Temp Alarms to Trip Relay Contacts .....	3-3
	Set Low CO <sub>2</sub> Alarm Limit .....	3-3
	Set High CO <sub>2</sub> Alarm Limit .....	3-4
	Enable CO <sub>2</sub> Alarms to Trip Relay Contacts .....	3-4
	Set New Zero No. for New CO <sub>2</sub> Sensors .....	3-5
	Set New Span No. for CO <sub>2</sub> Sensors .....	3-5
	Enable the High Humidity Feature .....	3-6
	Select a Primary Tank w/ Gas Guard Option .....	3-6
	Disable the Gas Guard System .....	3-7
	Set RS485 Address .....	3-7

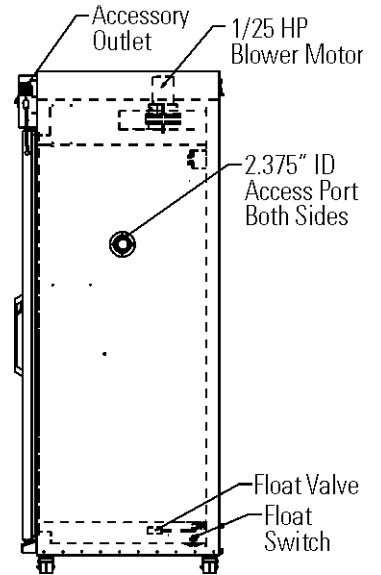


<b>Section 4</b>	<b>Alarms</b> .....	<b>4-1</b>
	Sensor Fault Alarms .....	4-2
	<b>Preventive Maintenance</b> .....	<b>4-3</b>
<b>Section 5</b>	<b>Maintenance</b> .....	<b>5-1</b>
	Cleaning .....	5-1
	Cleaning the Glass Doors .....	5-1
	Cleaning the Humidity Reservoir .....	5-2
	Replacing the Power Fuses .....	5-3
	Discarding/Removing Incubator from Service .....	5-3
<b>Section 6</b>	<b>Factory Options</b> .....	<b>6-1</b>
	Connect the Remote Alarm Contacts .....	6-1
	Connect the RS485 Interface (P/N 190523) .....	6-2
	Connect Analog Output Boards (P/N 190512, 190543, & 190544) .....	6-3
	CO <sub>2</sub> Gas Guard (P/N 1900000) .....	6-4
	Connect CO <sub>2</sub> Gas Supplies .....	6-5
	De-activate Gas Guard .....	6-5
	Operation of CO <sub>2</sub> Gas Guard .....	6-5
	Inner Doors .....	6-6
	Shaker Support Shelves .....	6-6
<b>Section 7</b>	<b>Specifications</b> .....	<b>7-1</b>
<b>Section 8</b>	<b>Spare Parts</b> .....	<b>8-1</b>
	Assembly Drawings .....	8-2
	Exploded Parts Drawings .....	8-3
<b>Section 9</b>	<b>Electrical Schematics</b> .....	<b>9-1</b>
<b>Section 10</b>	<b>Warranty</b> .....	<b>10-1</b>

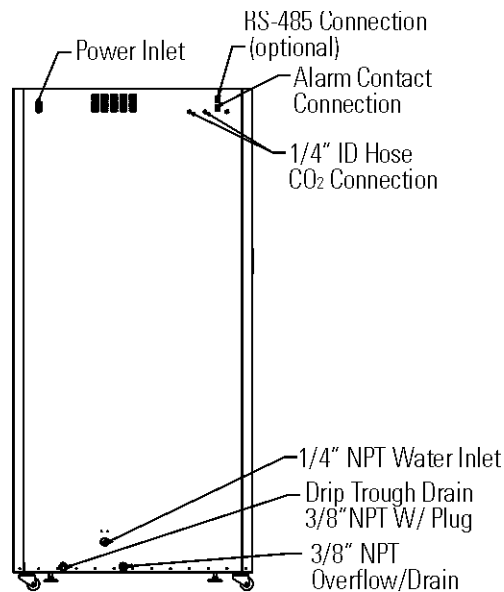
# Section 1 Installation and Start-Up



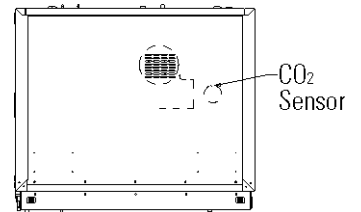
**Figure 1-1.** Front View



**Figure 1-2.** Side View

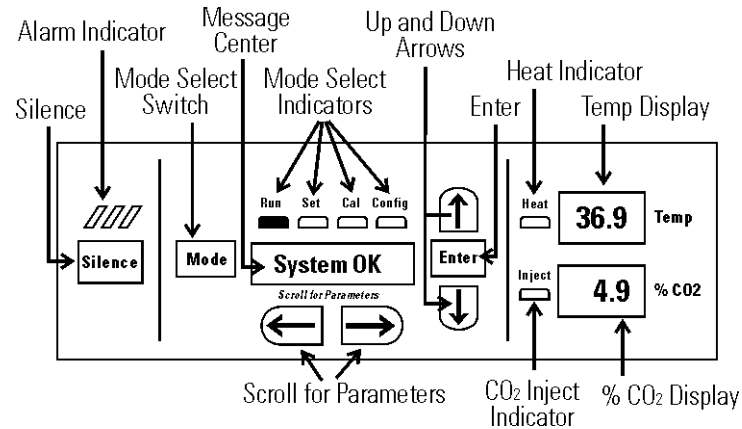


**Figure 1-3.** Back View



**Figure 1-4.** Top View

## Control Panel Keys, Displays, & Indicators



**Figure 1-4.** Control Panel Components

**Silence** - Silences the audible alarm.

**Alarm Indicator** - Light pulses on/off during an alarm condition in the cabinet.

**Mode Select Switch** - Used to select Run, Setpoints, Calibration and System Configuration Modes.

**Message Center** - Displays system status.

**Mode Select Indicators** -

- Run: Run Menu
- Set: Set Points Menu
- Cal: Calibrate Menu
- Config: Configuration Menu

**Up and Down Arrows** - Increases or decreases the number values, toggles between choices.

**Enter** - Stores the value into computer memory.

**Heat Indicator** - Lights when power is applied to the heaters.

**Temp Display** - Displays temperature continuously

**Scroll for Parameters Arrows** - Moves the operator through the choices of the selected mode.

**CO<sub>2</sub> Inject Indicator** - Lights when CO<sub>2</sub> is being injected into the incubator.

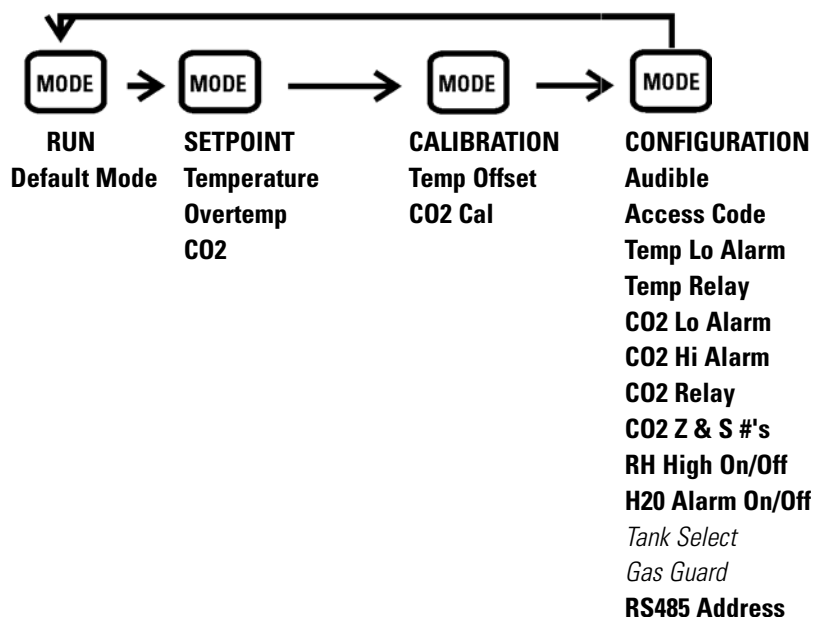
**% CO<sub>2</sub> Display** - Displays CO<sub>2</sub> percentage continuously.

## Keypad Operation

The Model 3950 Series Reach-In Incubator has four basic modes that allow incubator setup: Run, Setpoints, Calibration and System Configuration.

- Run is the default mode during normal operation.
- Set is used to enter system setpoints.
- Calibration is used to calibrate various system parameters.
- Configuration allows for custom setup of various options.

The chart below shows the selections under each of the modes.



**\*\*Base Unit Displays**

*\*\*Option Displays*

## Section 1

### Installation and Start-Up

#### Scroll for Parameters Arrows

Steps the operator through the parameters of SET, CAL and CONFIG Modes. The right arrow goes to the next parameter, the left arrow returns to the previous parameter.

#### Up Arrow

Increases or toggles the parameter values that have been selected in the SET, CAL, and CONFIG Modes.

#### Enter

Must press Enter key to save to memory all changed values.

#### Down Arrow

Decreases or toggles the parameter values that have been selected in the SET, CAL and CONFIG Modes.

#### Silence Key

Press to silence the audible alarm. See Section 4 for alarm ringback times.

## Unit Installation

**Caution** Units must be installed against a wall or similar structure. Maintain three-inch clearance behind the incubator for electrical, water and gas hook-ups. ▲

Locate the unit on a firm level surface capable of supporting the unit weight of approximately 500 lbs.

Locate the unit away from doors and windows and heating and air conditioning ducts.

**Warning** This incubator weighs approximately 500 lbs. Have sufficient personnel available when moving. ▲

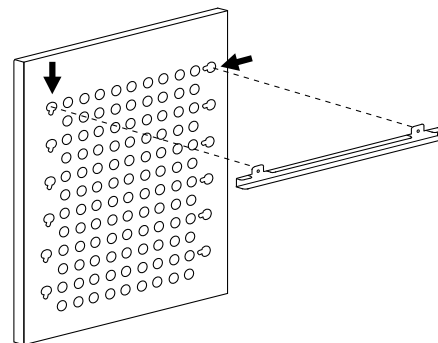
## Preliminary Cleaning and Disinfecting

Disinfect all interior surfaces with a general-use laboratory disinfectant. Rinse thoroughly with sterile distilled water, then 70% ethanol. Dry with a sterile cloth as needed. Disinfect the shelf channels and shelves, then rinse with distilled water before installing.

**Caution** Before using any cleaning or decontamination method except those recommended by the manufacturer, users should check with the manufacturer that the proposed method will not damage the equipment. Accidental spills of hazardous materials on or inside this unit are the responsibility of the user. ▲

## Installing the Shelves

The shelves may be installed at any level in the incubator. Install a shelf channel on each side. With the tabs pointing up, attach the channel by locating the rivet into a slotted hole, far end first. Pull the channel toward the front and slide the front rivet on the channel into the slotted hole and press down. Make sure that the channels are opposite each other so that the installed shelf will be level.



**Figure 1-5.** Shelf Channel

## Leveling the Unit

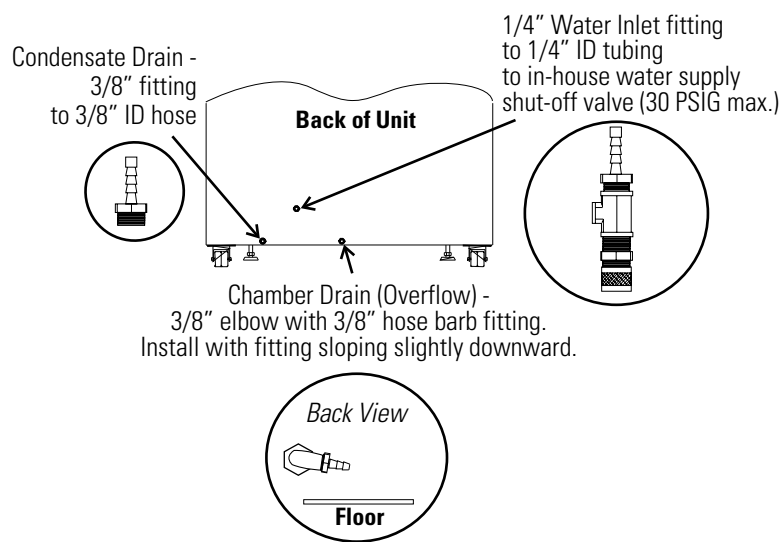
Place a bubble-type level on a shelf inside the incubator. Adjust the feet as needed; counterclockwise to lengthen or clockwise to shorten. Level the unit front-to-back and left-to-right.

## Attaching the Drain Lines

**Note** Drain connections on the back of the unit are shipped capped. If humidity is not required, the caps should be left on the drains. ▲

If manual or gravity feed method is used for humidity in the cabinet, connecting the drains is optional.

If an in-house pure water supply is used to fill the reservoir, it is recommended that the drains be connected to a floor drain.



**Figure 1-6.** Top View of Fitting Connections

## The Water Supply

For best operation of the incubator, sterilized distilled, demineralized or de-ionized water should be used in the humidity reservoir. Water purity should be in the resistance range of 50K to 1M Ohm/cm, or a conductivity range of 20.0 to 1.0 uS/cm. Refer to ASTM Standard D5391-93 or D4195-88 for measuring water purity.

Distillation systems, as well as some types of reverse osmosis water purity systems, can produce water in the quality range specified. Tap water is not recommended as it may contain chlorine, which can deteriorate the stainless steel. Tap water may also have a high mineral content, which would produce a build-up of scale in the reservoir. High purity or ultra pure water is not recommended as it is an extremely aggressive solvent and will deteriorate the stainless steel. High purity water has a resistance of above 1M to 18M Ohm. Even high purity water can contain bacteria and organic contaminants. Water should always be sterilized or treated with a decontaminant, safe for use with stainless steel as well as safe for the product, prior to being introduced into the humidity reservoir.

**Caution** Distilled or de-ionized water used in the humidity reservoir must be within a water quality resistance range of 50K to 1M Ohm/cm to protect and prolong the life of the stainless steel. Use of water outside the specified range will decrease the operating life of the unit and may void warranty. ▲

The incubator is equipped with a liquid level float switch that detects low water levels in the humidity reservoir and produces an alarm condition. As all applications do not require humidity, this alarm can be disabled. To disable the ADD WATER alarm, see Section 3. If humidity is required in the current application, press the Silence key on the control panel to mute the alarm while the humidity reservoir is being filled.

## Filling the Humidity Reservoir

There are three methods for filling the humidity reservoir; an in-house pure water supply, the manual and the gravity feed methods.

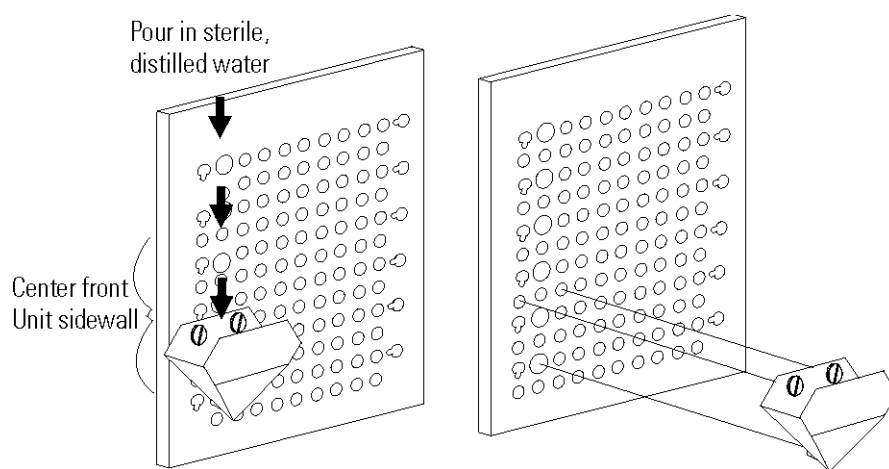
### In-house Pure Water Supply

All incubators provide a connection for using an in-house water supply. Connect a low pressure (not more than 30 PSI) water line, equipped with a manual shut-off valve, to the inlet fitting on the float valve reservoir. The 1/4" hose connection is located on the rear of the incubator cabinet. With the water turned on, a float valve inside the incubator regulates the water level in the humidity reservoir. When the reservoir is full, a 10-second audible tone is heard and the ADD WATER message no longer displays.

### Manual Method

This fill system consists of a funnel attached to the side duct sheet and tubing located inside the incubator. Disinfect the funnel and rinse with sterile water before using. This funnel may be moved to a preferred location by unscrewing the well nuts and disconnecting it from the sidewall. Tighten the nuts after relocation. The holes allotted for funnel use are slightly larger and in a centralized area. See Figure 1-6.

To fill the reservoir, pour sterile distilled water (approximately 2.5 gallons) into the funnel. When the float switch trips, a 10-second audible tone sounds and the ADD WATER message no longer displays. Add 1 gallon after the 10-second tone is heard.



**Figure 1-6.** Manual Feed Method with Funnel

### Gravity Feed Method

An optional carboy water fill system is also available. The carboy option kit includes an instruction sheet that details the installation of the system.

### Connecting the Unit to Electrical Power

See the serial tag on the side of the unit for electrical specifications or refer to the electrical schematics at the end of this manual.

**Warning** Connect the incubator to a grounded, dedicated circuit. The power cord connector is the mains disconnect device for the incubator. Position the incubator so the unit can be easily disconnected. ▲

Plug the provided power cord into the power inlet connector on the back of the cabinet, then into a grounded, dedicated electrical circuit.



## Connecting to Electrical Power (continued)

The Model 3950 Series also has an internal outlet located on the right side of the interior back wall. The outlet is to provide power (230W maximum) to accessory equipment. This outlet is not to be used when the temperature is above 40°C and the RH more than 50%.

## Connecting the CO<sub>2</sub> Gas Supply

**Warning** High concentrations of CO<sub>2</sub> gas can cause asphyxiation. OSHA Standards specify that employee exposure to carbon dioxide in any 8-hour shift of a 40-hour work week shall not exceed the 8-hour time weighted average of 5000 PPM (0.5% CO<sub>2</sub>). The short-term exposure limit for 15 minutes or less is 30,000 ppm (3% CO<sub>2</sub>). Carbon dioxide monitors are recommended for confined areas where concentrations of carbon dioxide gas can accumulate.

This incubator is designed for CO<sub>2</sub> gas only. Connecting a flammable or toxic gas could result in a hazardous condition.

Gases other than CO<sub>2</sub> should not be connected to this equipment. CO<sub>2</sub> gas cylinders have a UN1013 label on the cylinder and are equipped with a CGA 320 outlet valve. Check the gas cylinder for the proper identification labels. The CO<sub>2</sub> gas supply being connected to the incubator should be industrial grade, 99.5% pure. Do not use CO<sub>2</sub> gas cylinders equipped with siphon tubes. A siphon tube is used to extract liquid CO<sub>2</sub> from the cylinder, which can damage the pressure regulator. Consult with your gas supplier to ensure that the CO<sub>2</sub> cylinder does not contain a siphon tube. Gas cylinders should also be secured to a wall or other stationary object to prevent them from tipping.

A two-stage CO<sub>2</sub> pressure regulator is required to be installed on the outlet valve of the gas cylinder. Input pressure to the incubator must be maintained at 15 psig (103.4 kPa) for proper performance of the CO<sub>2</sub> control system. A single stage CO<sub>2</sub> pressure regulator will not maintain 15 psig (103.4 kPa) to the incubator as the pressure in the CO<sub>2</sub> cylinder decreases; therefore, a two-stage regulator is recommended.

If higher purity CO<sub>2</sub> is desired inside the incubator (greater than 99.5% pure), the pressure regulator should be constructed with a stainless steel diaphragm, along with specifying the purity of the CO<sub>2</sub> from the gas supplier. Follow the manufacturer's instructions to ensure proper and safe installation of the pressure regulator on the gas cylinder.

Consult your facility safety officer to ensure that the equipment is installed in accordance with the codes and regulations applicable in your area. ▲

## **Connecting CO<sub>2</sub> Gas Supply (continued)**

The CO<sub>2</sub> gas supply being connected should be industrial grade 99.5% pure and should not contain siphon tubes. Install a two-stage pressure regulator at the cylinder outlet. The high pressure gauge at the tank should have 0-2000 psig range. The low pressure gauge, at the incubator inlet, should have a 0-30 psig range. Input pressure to the incubator must be maintained at 15 psig (103.4 kPa), ±5 psig.

**Caution** Each tank should be connected to one incubator only. ▲

The incubator has serrated fittings on the back of the cabinet to connect the gas supply (Figure 1-2). The fitting is labeled CO<sub>2</sub> Inlet #1 Tank. Secure connections with clamps. Check all fittings for leaks.

For units having the CO<sub>2</sub> Gas Guard option, refer to Section 6.

## **Incubator Start-Up**

With the incubator properly installed, connected to power, the humidity reservoir filled and the unit connected to a gas supply, system setpoints can be entered. The following setpoints can be entered in Set Mode: Temperature, Overtemperature and CO<sub>2</sub>. To enter Set Mode, press the Mode key until the Set indicator lights. Press the right and/or left arrow keys until the proper parameter appears in the message display center. See Chart 1-1 for more detail.

## **Setting the Operating Temperature**

This incubator has an operating temperature setpoint range of 5.0°C above ambient to 60.0°C. It is shipped from the factory with a temperature setpoint of 10.0° C. At this setting, all heaters are turned off. To change the operating temperature setpoint:

1. Press the Mode key until the Set indicator lights.
2. Press the right arrow until “Temp XX.X” is displayed in the message center.
3. Press up/down until the desired temperature setpoint is displayed.
4. Press Enter to save the setpoint.
5. Press the Mode key until the Run indicator lights for Run mode or press the right/left arrow keys to go to next/previous parameter.

**Caution** Any equipment placed inside chamber must be rated for unit operating temperature and humidity. ▲

## Setting the Overtemp Setpoint

**Warning** The independent overtemp system is designed as a safety to protect the incubator only. It is not intended to protect or limit the maximum temperature of the cell cultures or customer's equipment inside the incubator if an overtemp condition occurs. ▲

All Model 3950 Series incubators are equipped with a secondary temperature monitoring system to monitor the air temperature inside the cabinet. This system is designed as a safety device to turn off all heaters in the event of a temperature control failure. The temperature control point in the incubator will be approximately  $\pm 1^{\circ}\text{C}$  of the overtemp setpoint.

The overtemp setpoint is set by the factory (default) at  $40^{\circ}\text{C}$ . However, the overtemp can be reset over a range from  $0.5^{\circ}\text{C}$  above the operating temperature setpoint to  $65^{\circ}\text{C}$ .

If the incubator's operating temperature setpoint is set above the overtemp setpoint, the overtemp setpoint will automatically update to  $1^{\circ}\text{C}$  above the temperature setpoint. It is recommended that the overtemp setpoint be maintained at  $1^{\circ}\text{C}$  over the operating temperature setpoint.

To set the Overtemp setpoint:

1. Press the Mode key until the Set indicator lights.
2. Press the right arrow until Otemp XX.X is displayed in the message center.
3. Press the up or down arrow until the desired Otemp setpoint is displayed.
4. Press Enter to save the setting.
5. Press the Mode key until the Run indicator lights, or press the right or left arrow to go to the next or previous parameter.

## Setting the CO<sub>2</sub> Setpoint

All CO<sub>2</sub> cells are calibrated at the factory at  $37^{\circ}\text{C}$ , medium humidity and 10% CO<sub>2</sub>. Therefore, if a temperature setpoint of  $37^{\circ}\text{C}$  has been entered, the humidity reservoir has been filled and the CO<sub>2</sub> control is set to run between 0-10%, the CO<sub>2</sub> setpoint may be entered immediately. Otherwise, it is important to allow the unit 12 hours to stabilize at the temperature setpoint before entering the CO<sub>2</sub> setpoint.

## **Setting the CO<sub>2</sub> Setpoint (continued)**

All models of the incubator have a CO<sub>2</sub> setpoint range of 0.0% to 20.0%. The incubator is shipped from the factory with a CO<sub>2</sub> setpoint of 0.0%. At this setting, all CO<sub>2</sub> control and alarms are turned off.

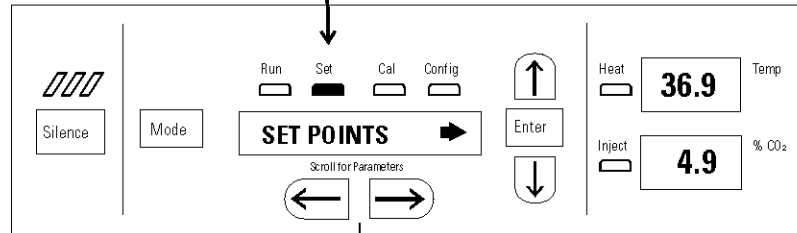
To change the CO<sub>2</sub> setpoint:

1. Press the Mode key until the Set indicator lights.
2. Press the right arrow until “CO<sub>2</sub> XX.X” is displayed in the message center.
3. Press the up/down arrow until the desired CO<sub>2</sub> setpoint is displayed.
4. Press Enter to save the setpoint.
5. Press the Mode key until the Run indicator lights to go to Run mode, or press the right/left arrow keys to go to next/previous parameter.

Chart 1-1

# Set Mode

Press MODE to light SET

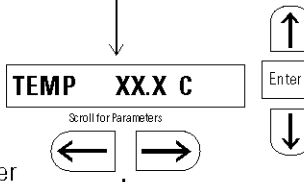


To Set:

**Operating Temperature**

Press MODE to move to CALIBRATE mode.

Press ← to return to previous parameter



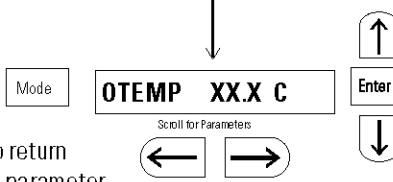
Numbers increase

Press Enter to save setting

Numbers decrease

**Over Temperature**

Press ← to return to previous parameter



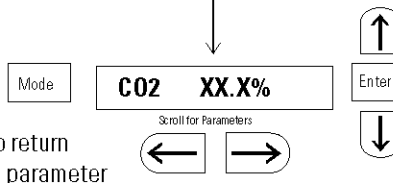
Numbers increase

Press Enter to save setting

Numbers decrease

**Percent CO<sub>2</sub>**

Press ← to return to previous parameter



Numbers increase

Press Enter to save setting

Numbers decrease

## Section 2 Calibration

After the unit has stabilized, several different systems can be calibrated. In the calibration mode, the air temperature, CO<sub>2</sub> and RH levels can be calibrated to reference instruments. To access the calibration mode, press the Mode key until the Cal indicator lights. Press the right and/or left arrow until the proper parameter appears in the message center. See Chart 2-1 at the end of this section for more detail.

Calibration frequency is dependent on use, ambient conditions and accuracy required. A good laboratory practice would require at least an annual calibration check. On new installations, all parameters should be checked after the stabilization period.

Prior to calibration, the user should be aware of the following system functions. While the unit is in the calibration mode, all system control functions are stopped so the unit remains stable. Readout of the system being calibrated will appear on the message center. If no keys are pressed for approximately five minutes while in Calibration mode, the system will reset to Run mode so control functions are reactivated.

**Caution** Before making any calibration or adjustments to the unit, it is imperative that all reference instruments be properly calibrated. ▲

### Calibrating the Temperature

Before calibration, allow the cabinet temperature to stabilize. Place the calibrated instrument in the center of the chamber. The instrument should be in the airflow, not against the shelf.

#### Temperature Stabilization Periods

**Start-Up** - Allow 12 hours for the temperature in the cabinet to stabilize before proceeding.

**Presently Operating** - Allow at least 2 hours after the display reaches setpoint for temperature to stabilize before proceeding.

## Calibrating Temp (continued)

1. Press the Mode key until Cal indicator lights.
2. Press the right arrow until “TEMPCAL XX.X” appears in the message center.
3. Press the up/down arrow to match the display to the calibrated instrument.
4. Press Enter to store calibration.
5. Press the Mode key to return to Run or the right/left arrow to go to next/previous parameter.

## Calibrating the CO<sub>2</sub> System

Model 3950 Series incubators have a CO<sub>2</sub> sensor. The incubator atmosphere is not only effected by the quantity of CO<sub>2</sub> present but also by the air temperature and water vapor present in the incubator atmosphere. In monitoring the effects of CO<sub>2</sub>, air temperature and absolute humidity must be held constant so any change is caused by a change in CO<sub>2</sub> concentration.

Changing temperature or changing from elevated humidity to room ambient humidity levels will require re-calibration of the CO<sub>2</sub> control.

### CO<sub>2</sub> Sensor Stabilization Periods

**Start-Up** - The CO<sub>2</sub> sensor has been calibrated at the factory for 37°C and elevated humidity. Allow the temperature, humidity and CO<sub>2</sub> levels in the chamber to stabilize at least 12 hours before checking the CO<sub>2</sub> concentration with an independent instrument.

**Presently Operating** - Make sure the chamber doors are closed. Allow at least 2 hours after the temperature and CO<sub>2</sub> displays reach their setpoints for chamber atmosphere stabilization.

## **Calibrating the CO<sub>2</sub> System (continued)**

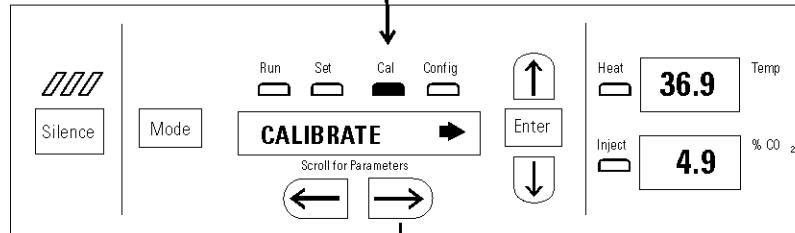
1. Make sure the stabilization periods outlined above are followed.
2. Sample the chamber atmosphere through the sample port with an independent instrument. Sample the atmosphere at least 3 times to ensure accuracy of the instrument.
3. Press the Mode key until the Cal indicator lights.
4. Press the right arrow until “CO<sub>2</sub> CAL XX.X” is displayed in the message center.
5. Press the up /down arrows to change the display to match the independent instrument.
6. Press Enter to store the calibration.
7. Press the Mode key to return to Run or the right or left arrows to go to the next/ previous parameter.



Chart 2-1

# Calibrate Mode

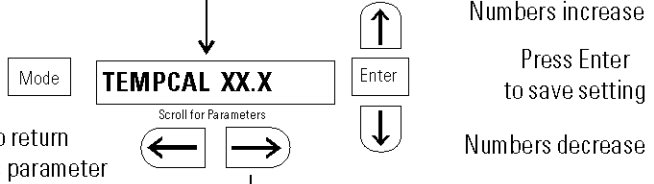
**Press MODE to light CAL**



To Calibrate:

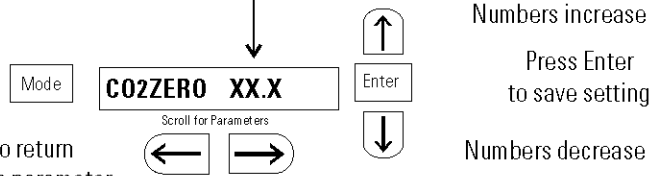
**Operating Temperature**

Press MODE to move to SYS CONFIG mode.



**CO<sub>2</sub>**

Press **←** to return to previous parameter



## Section 3 Configuration

Several features available in Configuration Mode allow custom setup of the incubator. These features are listed and described below. All features may not be necessary in all applications, but are available if needed. To enter Configuration mode, press the Mode key until the Config indicator lights. Press the right and/or left arrow until the appropriate parameter appears in the message center. See Chart 3-1 at the end of this section for more detail.

### Disable the ADD WATER Alarm

All applications do not require humidity. For this reason, the ADD WATER alarm can be disabled. The factory default for the ADD WATER alarm is ON.

1. Press Mode key until Config indicator lights.
2. Press right arrow until H2O ALM XXX is displayed in message center.
3. Press up/down arrow to toggle H2O ALM ON or OFF.
4. Press Enter to save the setting.
5. Press Mode key to return to Run mode or right/left to go to next/previous parameter.

**Note** Verify that the RH HIGH feature is set to OFF after disabling the ADD WATER alarm. ▲

### Turn All Audible Alarms ON/OFF

The audible alarms can be turned on or off. The factory setting is ON.

1. Press Mode key until Config indicator lights.
2. Press right arrow until Audible XXX is displayed in message center.
3. Press up/down arrow to toggle Audible ON/OFF.
4. Press Enter to save the setting.
5. Press Mode key to return to Run mode or right/left to go to next/previous parameter.

## Set an Access Code

A 3-digit Access Code can be entered to avoid unauthorized personnel from changing the setpoints, calibration, or configuration. A setting of 000 will bypass the access code. The factory setting is 000.

1. Press the Mode key until the Config indicator lights.
2. Press the right arrow until Acc Code XXX is displayed in the message center.
3. Press up or down arrow to change the access code.
4. Press Enter to save the access code.
5. Press the Mode key to return to the Run mode or right/left to go to next/previous parameter.

## Set a Low Temp Alarm Limit

The low temperature alarm limit (tracking alarm) is the deviation from the temperature setpoint, which will cause a low temp alarm. The low temp alarm is variable from 0.5° below setpoint to 5.0° below setpoint. The factory setting is 1.0° below setpoint. A minus sign in the display indicates that the alarm setting is below the setpoint.

1. Press the Mode key until the Config indicator lights.
2. Press the right arrow until Temp Lo -X.X is displayed in the message center.
3. Press up/down arrow to change the low temp alarm limit.
4. Press Enter to save the low temp alarm limit.
5. Press the Mode key to return to Run mode or right/left to go to next/previous parameter.

## **Enable Temp Alarms to Trip Relay Contacts**

The temperature alarms can be programmed to trip the remote alarm contacts. A setting of ON will cause this, a setting of OFF will not allow temperature alarms to trip the contacts. The factory setting is ON.

1. Press the Mode key until the Config indicator lights.
2. Press the right arrow until TMP RLY XXX is displayed.
3. Press the up/down arrow to toggle the setting ON/OFF.
4. Press Enter to save the setting
5. Press the Mode key to return to Run or the right/left arrow key to go to next/previous parameter.

## **Set Low CO<sub>2</sub> Alarm Limit**

The low CO<sub>2</sub> alarm limit (tracking alarm) is the deviation from the CO<sub>2</sub> setpoint, which will cause a low CO<sub>2</sub> alarm. The setpoint is variable from 0.5 % CO<sub>2</sub> below setpoint to 5.0 % CO<sub>2</sub> below setpoint. The factory setting is 1.0 % CO<sub>2</sub> below setpoint. A minus in the display indicates that the alarm setting is below the setpoint.

1. Press the Mode key until the Config indicator lights.
2. Press the right arrow until CO<sub>2</sub> LO -X.X is displayed in the message center.
3. Press up/down arrow to change the low CO<sub>2</sub> alarm limit.
4. Press Enter to save the low CO<sub>2</sub> alarm limit.
5. Press the Mode key to return to Run mode or right/left to go to next/previous parameter.

## Set High CO<sub>2</sub> Alarm Limit

The high CO<sub>2</sub> alarm limit (tracking alarm) is the deviation from the CO<sub>2</sub> setpoint, which will cause a high CO<sub>2</sub> alarm. The setpoint is variable from 0.5 % CO<sub>2</sub> above setpoint to 5.0 % CO<sub>2</sub> above setpoint. The factory setting is 1.0 % CO<sub>2</sub> above setpoint.

1. Press the Mode key until the Config indicator lights.
2. Press the right arrow until CO<sub>2</sub> HI X.X is displayed in the message center.
3. Press up/down arrow to change the high CO<sub>2</sub> alarm limit.
4. Press Enter to save the high CO<sub>2</sub> alarm limit.
5. Press the Mode key to return to run mode or right/left to go to next/previous parameter.

## Enable CO<sub>2</sub> Alarms to Trip Relay Contacts

High and Low CO<sub>2</sub> alarms can be programmed to trip the remote alarm contacts. A setting of ON will cause this, a setting of OFF will not allow CO<sub>2</sub> alarms to trip the contacts. The factory setting is ON.

1. Press the Mode key until the Config indicator lights.
2. Press the right arrow until CO<sub>2</sub> RLY XXX is displayed in the message center.
3. Press up/down arrow to toggle the setting ON/OFF.
4. Press Enter to save the setting.
5. Press the Mode key to return to Run Mode or right/left to go to next/previous parameter.

## Set New Zero No. for New CO<sub>2</sub> Sensors

If a new CO<sub>2</sub> sensor is being installed, the two numbers on the factory installed sticker on the cell must be entered to calibrate the CO<sub>2</sub> in the unit.

**Note** For the technician's convenience, a label containing the two numbers on the cell is affixed inside the electronics drawer. ▲

1. Press the Mode key until the Config indicator lights.
2. Press the right arrow until Z# XXXX is displayed in the message center.
3. Press up/down arrow to change the zero number to match the sticker.
4. Press Enter to save the setting.
5. Press the Mode key to return to Run mode or right/left to go to next/previous parameter.

## Set New Span No. for CO<sub>2</sub> Sensors

If a new CO<sub>2</sub> sensor is being installed, the two numbers on the factory installed sticker on the cell must be entered to calibrate the CO<sub>2</sub> in the unit.

**Note** For the technician's convenience, a label containing the two numbers on the cell is affixed inside the electronics drawer. ▲

1. Press the Mode key until the Config indicator lights.
2. Press the right arrow until S# XXXX is displayed in the message center.
3. Press up/down arrow to change the span number to match the sticker.
4. Press Enter to save the setting.
5. Press the Mode key to return to Run mode or right/left to go to next/previous parameter.

## Enable the High Humidity Feature

In normal operation, the incubator will maintain the humidity level above 80%. If a higher RH level is required, the RH HIGH feature may be turned ON. This allows the heater attached to the humidity reservoir to be enabled, resulting in RH levels above 90%. The factory default for the RH HIGH feature is OFF.

1. Press the Mode key until the Config indicator lights.
2. Press the right arrow until RH HIGH XXX is displayed in the message center.
3. Press up/down arrow to toggle RH HIGH ON or OFF.
4. Press Enter to save the setting.
5. Press the Mode key to return to Run mode or right/left to go to next/previous parameter.

**Note** Verify that the ADD WATER alarm is set to ON after enabling the RH HIGH feature. ▲

## Select a Primary Tank w/ Gas Guard Option

On units equipped with the Gas Guard option, a primary tank can be selected. The primary tank will be either Tank 1 or 2. The factory setting is Tank 1.

1. Press the Mode key until the Config indicator lights.
2. Press the right arrow until Tank Sel X is displayed in the message center.
3. Press the up/down arrow to toggle the setting between 1 and 2 .
4. Press Enter to save the setting.
5. Press the Mode key to return to Run mode or right/left to go to next/previous parameter.

## **Disable the Gas Guard System**

On units equipped with the Gas Guard option, the Gas Guard system may be turned ON, or OFF if it is not in use. The factory setting is ON.

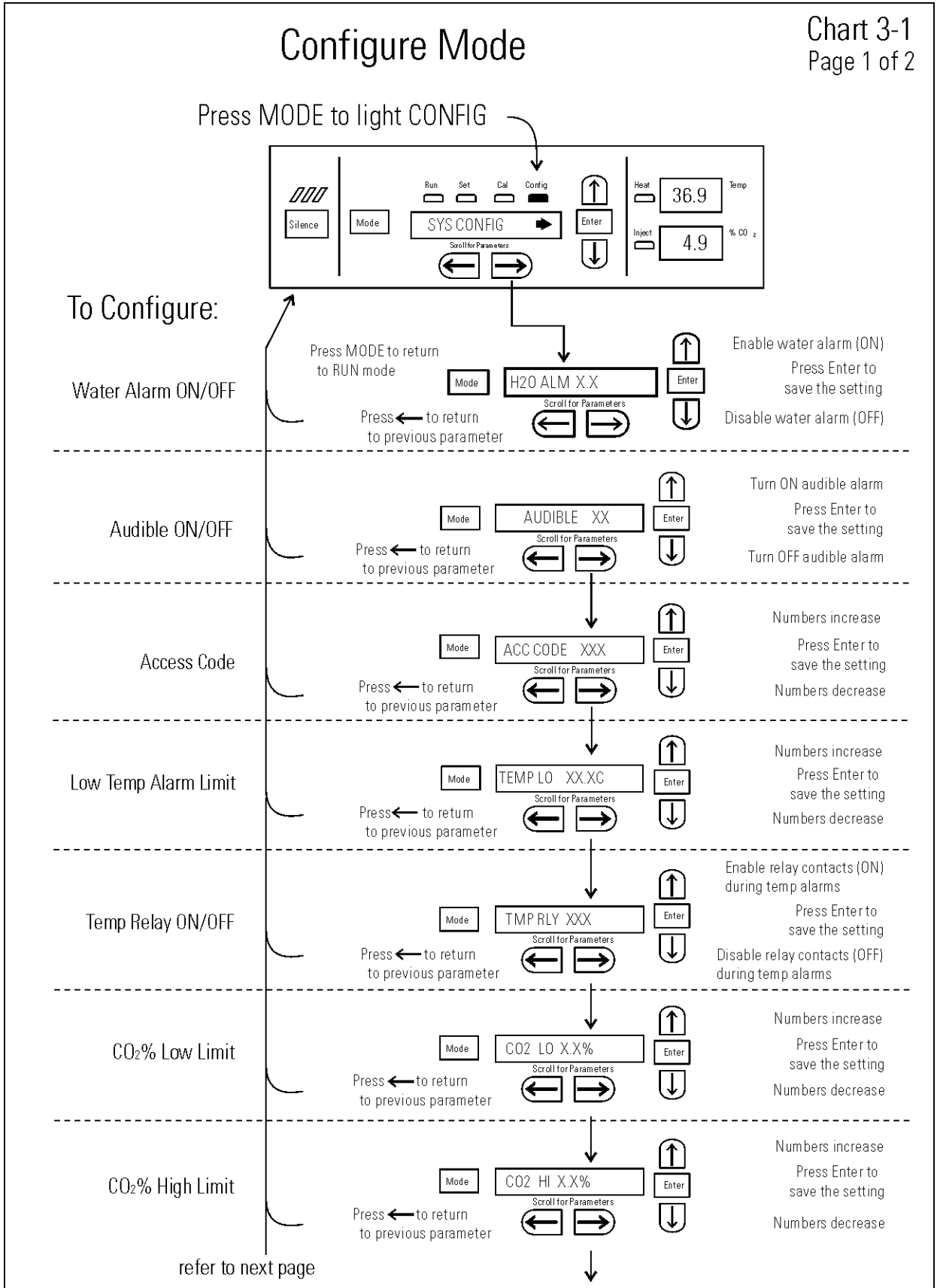
1. Press the Mode key until the Config indicator lights.
2. Press the right arrow until Gas Grd XX is displayed in the message center.
3. Press up/down arrow to toggle the setting ON/OFF.
4. Press Enter to save the setting.
5. Press the Mode key to return to Run mode or right/left to go to next/previous parameter.

## **Set RS485 Address**

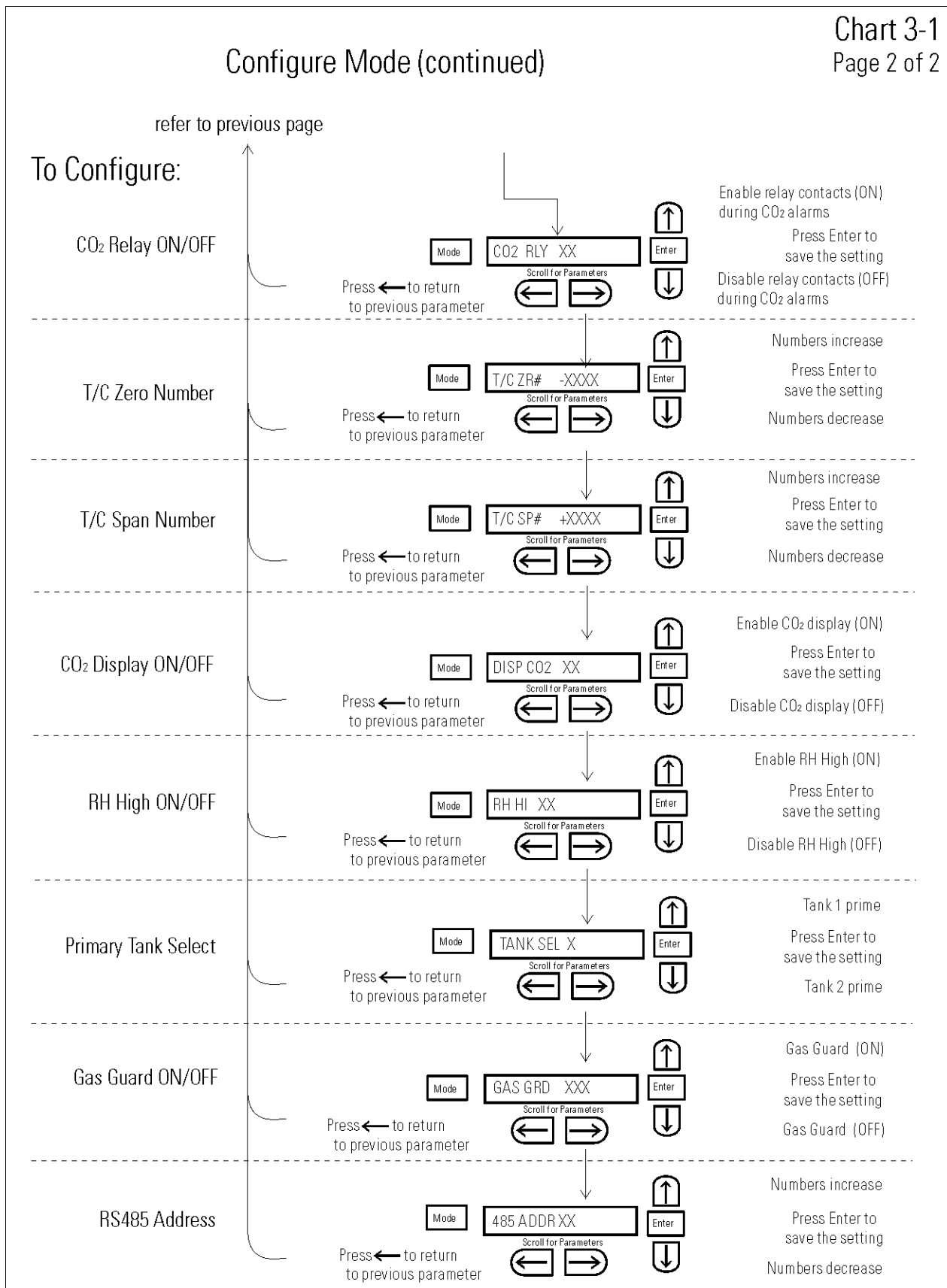
On units that have the RS485 option, direct communication with the Model 1535 alarm system can be established. Each piece of equipment connected to the 1535 must have a unique address. An address of 0-24 can be entered for the incubator. A setting of 0 is an invalid address that the 1535 will ignore. The factory setting for the RS485 address is 0.

1. Press the Mode key until the Config indicator lights.
2. Press the right arrow until RS485 XX is displayed in the message center.
3. Press up/down arrow to move the RS485 address.
4. Press Enter to save the RS485 address.
5. Press the Mode key to return to Run mode or right/left to go to next/previous parameter.





**Chart 3-1**  
Page 2 of 2





## Section 4 Alarms

The Model 3950 Series incubator is equipped with a system that notifies the user of an alarm condition inside the incubator. All alarms display in the control panel message center. The following table contains information on all possible system alarms.

**Table 4-1.** Alarms

Description	Message Code	Delay	Ringback	Relay
No alarm condition exists	SYSTEM OK	----	----	----
Temp > Otemp Set point	SYS IN OTEMP	0 min.	15 min.	Yes
Air Temp Sensor Fault (See Section 4.2)	AIR SNSR ERR	0 min.	15 min.	No
Temperature Controller Failure (See Section 4.2)	TMP CTRL ERR	0 min.	15 min.	YES
CO2 Sensor Fault (See Section 4.2)	CO2 SNSR ERR	0 min.	15 min.	No
Water Level in Reservoir is Low	ADD WATER	0 min.	15 min.	No
Inner Door is Open	DOOR IS OPEN	15 min.	15 min.	No
CO2 > CO2 High Tracking Alarm	CO2 IS HIGH	15 min.	15 min.	Programmable
CO2 < CO2 Low Tracking Alarm	CO2 IS LOW	15 min.	15 min.	Programmable
TEMP < TEMP Low Tracking Alarm	TEMP IS LOW	15 min.	15 min.	Programmable
Tank 1 is low, switch to Tank 2 (Gas Guard only)	TANK1 LOW	0 min.	---	No
Tank 2 is low, switch to Tank 1 (Gas Guard only)	TANK2 LOW	0 min.	---	No
Both tanks are low (Gas Guard only)	TANK 1 and 2 LOW	0 min.	15 min.	No

All alarm delays and ringback times are  $\pm 30$  seconds.

To avoid alarms going off in day-to-day use, some alarms are equipped with a time delay feature. For this to function correctly, the alarm condition must exist for the specified length of time before the message center will display the alarm. This allows for interruptions, such as door openings, to occur without the incubator going into a continuous state of alarm.

When an alarm condition exists, press the Silence key to temporarily mute the audible alarm. The message center continues to show the alarm condition. If the alarm condition is not corrected within a specified length of time, the alarm sounds again or “ringback” to remind the user.

When multiple alarm conditions occur, active messages are displayed in the display center one at a time, updating at 5-second intervals. Pressing Silence during multiple alarms causes all active alarms to be muted and to ringback in 15 minutes.

The temperature alarms are disabled when the Temp set point is 10°C. The CO<sub>2</sub> alarms are disabled when the CO<sub>2</sub> set point is 0.0%.

## **Sensor Fault Alarms**

The microprocessor in 3950 Series incubators continually scans all available sensors to ensure that they are operating properly. Should an error be detected, the incubator will sound an alarm and display the appropriate message. If such an alarm occurs, contact your local distributor or the Technical Services Department at 740-373-4763 or 1-888-213-1790 (U.S.A. and Canada) or fax 740-373-4189.

## PREVENTIVE MAINTENANCE

### Incubators

Your equipment has been thoroughly tested and calibrated before shipment. Regular preventive maintenance is important to keep your unit functioning properly. The operator should perform routine cleaning and maintenance on a regular basis. For maximum performance and efficiency, it is recommended the unit be checked and calibrated periodically by a qualified service technician.

The following is a condensed list of preventive maintenance requirements. See the specified section of the operating manual for further details.

We have qualified service technicians, using NIST traceable instruments, available in many areas. For more information on Preventive Maintenance or Extended Warranties, please contact us at the number listed below.

Cleaning and calibration adjustment intervals are dependent upon use, environmental conditions and accuracy required.

**Tips for all incubators:**

- Do NOT use bleach or any disinfectant that has high chloros
- Do not use powdered gloves for tissue cultures.
- Use sterile, distilled or demineralized water.

### Preventive Maintenance for 3950 Series Incubators

Refer to Manual Section	Action	Daily	Weekly	Yearly
1	Check CO <sub>2</sub> tank levels.	✓		
1	Check CO <sub>2</sub> and temperature display versus setpoints, w/ independent instrument		✓	
--	Inspect door latch, hinges and door gasket seal.			✓
2	Verify and document CO <sub>2</sub> and temp calibration, as applicable. See Calibration section.			✓
1 & 5	Perform a complete decontamination procedure. Wipe down interior, shelves and side panels with disinfectant. Drain water reservoir and wipe down with disinfectant. Rinse everything well with sterile distilled water.	Between experiments <i>More frequent decontamination may be required, depending on use and environmental conditions</i>		
Figure 6-5	*Change CO <sub>2</sub> filter (under normal conditions)			✓
1	Check operation of the float assembly and water level switch			✓
--	Replace the AquaTec water cleaning cell, if applicable, every six months.			

\* *Qualified service personnel*



## Section 5 Maintenance

**Warning** If the unit has been in service, turn it off and disconnect the power cord connector before proceeding with any maintenance. ▲

**Caution** Before using any cleaning or decontamination method not recommended by manufacturer, users should check with manufacturer that the proposed method would not damage the equipment. ▲

### Cleaning

The chamber interior may be cleaned with a general-use laboratory disinfectant or alcohol.

The cabinet exterior may be cleaned with soap and water or any non-abrasive commercial glass cleaner. The Thermopane glass door may be cleaned with commercial glass cleaner or with a solution of ammonia and water.

**Warning** Alcohol, even a 70% solution, is volatile and flammable. Use it only in a well ventilated area that is free from open flame. If any component is cleaned with alcohol, do not expose the component to open flame or other possible hazard. ▲

**Caution** Do not use strong alkaline or caustic agents. Stainless steel is corrosion resistant, not corrosion proof. Do not use solutions of sodium hypochlorite (bleach) as they may cause pitting and rust. ▲

### Cleaning the Glass Doors

The chamber glass door and the optional independent inner doors may be cleaned using the same disinfectant as used on the incubator interior. It is imperative that they be rinsed with sterile distilled water to remove the disinfectant residue. The doors should then be dried with a sterile soft cloth.



## Cleaning the Glass Doors (continued)

Some precautions in the cleaning and care of the incubator glass doors: Moisture leaches alkaline materials (sodium, Na) from the surface of the glass. Evaporation of the moisture concentrates the alkaline and may produce a white staining or clouding of the glass surface. Cleaning chemicals with a PH above 9 accelerate the corrosion process. Therefore, it is very important to rinse and dry the glass doors after cleaning. There is no simple method for repairing corroded glass. In most cases, the glass must be replaced.

## Cleaning the Humidity Reservoir

Periodic cleaning of the humidity reservoir beneath the incubator floor is recommended in order to remove bacteria, fungi or any accumulated mineral deposits.

1. Turn off and/or disconnect the water supply to the humidity reservoir.
2. Attach a drain fitting and hose to the drain port on the back of the unit. Run the hose to an appropriate drain.
3. With an adjustable wrench, remove the brass overflow fitting located at the rear of the humidity reservoir. Allow reservoir to drain. Reservoir holds approximately 4 gallons (15.4 L).
4. Disassemble the hose bracket from the incubator floor.
5. Remove the 8 screws securing the floor. Using the circular black plastic grommet, slide the floor outward to expose the humidity reservoir.
6. Remove any remaining water and sediment from the reservoir with a clean sponge.
7. Clean the reservoir with a general-use laboratory disinfectant. Rinse well with sterile distilled water and wipe dry with a clean cloth.

**Note** On reassembly, brass overflow fitting must be checked for leaks. ▲

**Caution** Use of chlorinated water, or decontamination products containing chlorine, will deteriorate the stainless steel and cause rust, voiding the warranty. ▲

**Caution** Do not use strong alkaline or caustic agents. Stainless steel is corrosion resistant, not corrosion proof. ▲

## Replacing the Power Fuses

**Warning** De-energize all potential sources of energy to this unit and lockout/tagout their controls. (O.S.H.A. Regulation, Section 1910-147.) ▲

**Warning** High voltage is present behind control panel. The remote overtemp alarm system should be installed only by qualified electrical service personnel. ▲

There are only two replaceable fuses in the incubator.

1. Turn off the incubator's power switch and unplug the power cord.
2. Remove the top of the unit to access the fuses.
3. Refer to Figure 6-5 for the location of the two fuses.
4. Install the top cover and return the unit to service. If the fuse(s) blow after restoring power to the incubator, contact the Technical Services Department at the telephone number on Page iv of this manual.

**Table 5-1.** Fuse Replacement Chart

Fuse Voltage and Application	Manufacturers Part #	Amp Rating	Rupture Speed	IEC Letter Code
115 VAC Accessory Outlet	GMC-1A	1.0 Amp	Time-Lag	T
230 VAC Accessory Outlet	GMC-500mA	0.5 Amp	Time-Lag	T
115 VAC Interior Outlet	GMC-2.5A	2.5 Amp	Time-Lag	T
230 VAC Interior Outlet	GMC-1.5A	1.5 Amp	Time-Lag	T

## Discarding/Removing Incubator from Service

**Caution** Federal regulations require that doors be removed from incubators before units are removed from service or discarded. ▲

**Caution** When operating this unit under high temperatures and/or relative humidity (RH), caution must be observed when the unit is shut down, unexpectedly or by choice. Condensate can form on the interior of the chamber as it cools. This includes the heating element surfaces. Heavy condensate can bridge the ceramic insulators and cause a temporary electrical short to ground. This electrical circuit is protected by a circuit breaker. However, to avoid this contingency if these conditions occur, open the door of the unit and allow it to stand open until the water vapor disperses. ▲



## Section 6 Factory Options

Instructions for connecting the incubator to external equipment follow.

### Connect the Remote Alarm Contacts

A set of relay contacts is provided to monitor alarms through a RJ-11 telephone style connector on the back of the unit. Refer to Figure 6-3 for the location of the alarm connector. The 12-foot telephone cord (P/N 190388) and RJ11-to-screw terminal conversion box (190392) are available through the Technical Services Department.

The remote alarm provides a NO (normally open) output, an NC (normally closed) output and COM (common). Refer to Figure 6-1.

The contacts will trip on a power outage or an overtemperature condition. The contacts may also be programmed to trip or not trip on temperature alarms and CO<sub>2</sub> alarms. See Section 3, Configuration Mode.

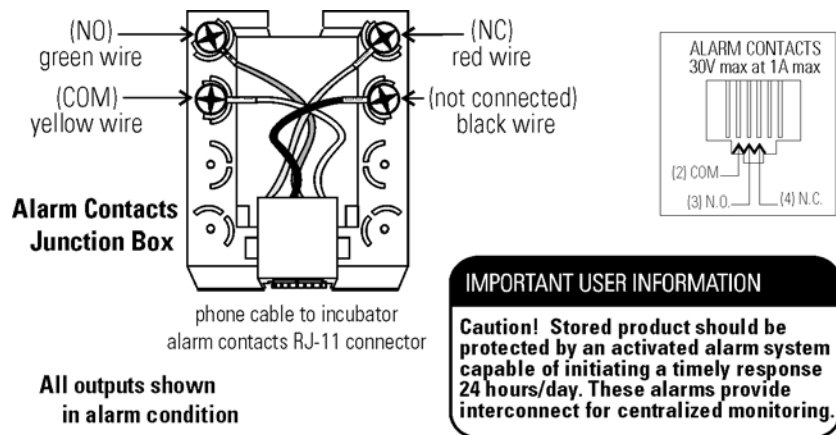


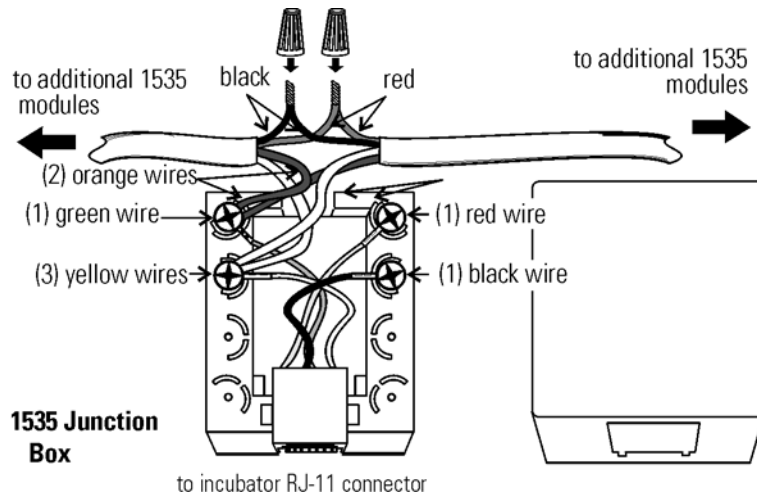
Figure 6-1. Remote Alarm Outputs



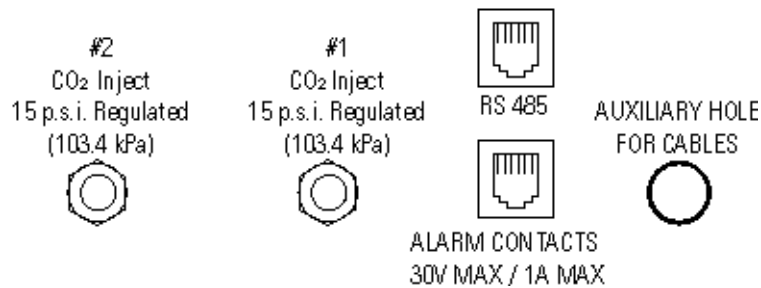
## Connect the RS485 Interface (P/N 190523)

All incubator models can be purchased with the RS485 communications option. This option allows the incubator to be directly connected to a Model 1535 alarm system without the use of a communications module. A junction box is provided with each RS485 option. Refer to Figure 6-2 for wiring details. Figure 6-3 shows the location of the RS485 connector on the back of the incubator.

To allow the incubator and the 1535 to communicate, an address must be allocated on the 1535. Refer to Section 5.8 of the 1535 operating manual. The same address number must be assigned to the incubator. Refer to Section 3, Configuration Mode, of this manual.



**Figure 6-2.** RS485 Interface Wiring



**Figure 6-3.** RS485 Connector Location on Unit Back

## Connect Analog Output Boards (P/N 190512, 190543, & 190544)

**Warning** The electronics section contains hazardous voltages. Only qualified electrical service personnel should access this area. ▲

The analog output board is an option that allows the incubator to output analog signals representing the air temperature and CO<sub>2</sub> content of the incubator interior. There are three different analog output board options available: 0-1V, 0-5V or 4-20mA signals. Negative display readings will output 0V. The outputs do not have isolated grounds. See Table 6-1 for output specifications of the three boards.

**Table 6-1.** Analog Output Board Specifications

	<b>190512 4-20 mA Output Scaling 4-20mA Equals</b>	<b>190544 0-1V Output Scaling 0-1V Equals</b>	<b>190543 0-5V Output Scaling 0-5V Equals</b>
Temperature	0.0-100.0 °C	0.0-100.0 °C	0.0-100.0 °C
CO <sub>2</sub>	0.0-100.0 %CO <sub>2</sub>	0-100.0 %CO <sub>2</sub>	0-100.0 %CO <sub>2</sub>

For the 0-1V and 0-5V boards, the recording device must supply a load  $\geq 1000$  ohm. For the 4-20mA board, the recorder must supply a load of  $\leq 100$  ohm.

To wire in the analog output board, the shielded 22 gauge, 3-conductor wire, Part # 73041, is recommended, maximum length 50 ft (15.2m). This wire is also readily available from other vendors including Alpha, Part #2403, and Deerborn, Part # 972203.

**Caution** Accuracy of the output at the board terminal strip to the incubator display is  $\pm 1$  unit. There is no calibration from the incubator. Calibration to the incubator display must be at the instrument connected to the output board. ▲

To access the analog board:

1. Turn off the incubator and disconnect it from the power source.
2. Remove the top of the incubator.
3. Locate the Analog Output board.

*(continued)*

- Strip the ends of the conductor and wire it to the appropriate terminals of connectors J2 on the analog board. Refer to Figure 6-4.

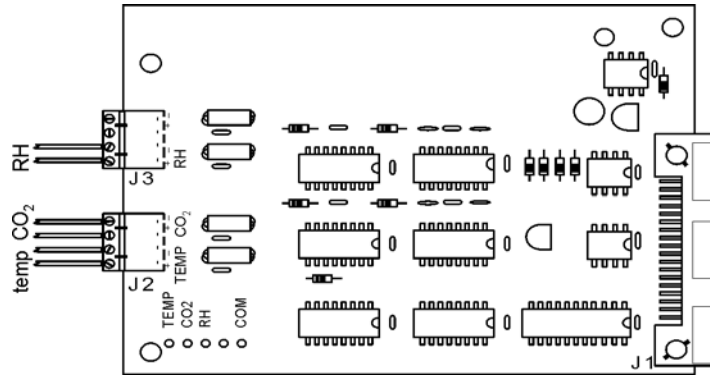


Figure 6-4. Terminals on Analog Board

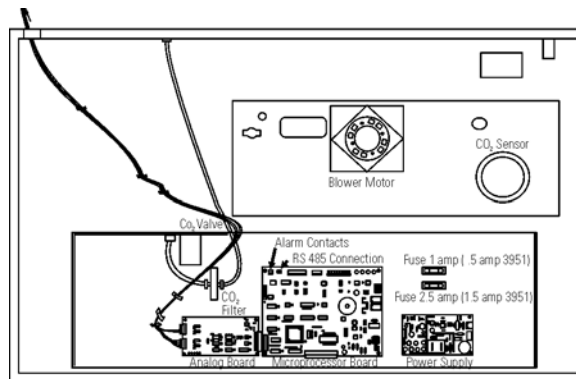


Figure 6-5. Route Wires

- Route the wires through the auxiliary hole located on the back of the unit. See Figure 6-3 and Figure 6-5.
- When wiring is completed, replace the unit top and return the unit to service.

## CO<sub>2</sub> Gas Guard (P/N 1900000)

**Warning** CO<sub>2</sub> can be lethal in high concentrations. Refer to the warnings in Section 1 of this manual. ▲

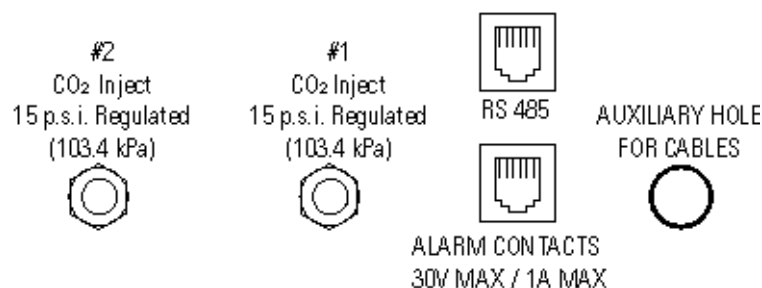
The 3950 Series incubators can be equipped with a built-in Gas Guard system that will operate with a CO<sub>2</sub> gas supply. The Gas Guard uses two pressure switches to continuously monitor the pressures of two independent CO<sub>2</sub> supplies and automatically switches from one supply to the other when the supply pressure drops below 10 psig (0.690 bar). Do not use the Gas Guard with multiple incubators.

## CO<sub>2</sub> Gas Guard (continued)

The CO<sub>2</sub> gas supplies must be equipped with two-stage pressure regulators with gauges. The high pressure gauge at the tank should have a 0-2000 psig range and the low pressure gauge should have a 0-30 psig range. The gas supply to the incubator must be maintained at 15 psig (1.034 bar). Gas pressures below 15 psig will cause nuisance alarms to occur on incubators equipped with the built-in Gas Guard.

### Connect CO<sub>2</sub> Gas Supplies

The CO<sub>2</sub> inlets for the Gas Guard are located on the back of the unit. Using 1/4" ID tubing, connect one of the CO<sub>2</sub> supply tanks to the fitting labeled CO<sub>2</sub> Inlet #1 Tank. Connect the second CO<sub>2</sub> supply tank to the fitting labeled CO<sub>2</sub> Inlet #2 Tank. Install 3/8" hose clamps to secure the 1/4" ID tubing to the fittings. Refer to Figure 6-6.



**Figure 6-6.** CO<sub>2</sub> Connections on Unit Back

### De-activate Gas Guard

The built-in Gas Guard is turned ON when shipped from the factory. The tank selected (Tank Sel) has been specified as Tank 1. Refer to Section 3 Configuration, to de-activate the Gas Guard or change Tank Sel from #1 to #2. If the Gas Guard system is not used, the incubator functions normally by supplying CO<sub>2</sub> from the supply tank connected to Inlet #1.

### Operation of CO<sub>2</sub> Gas Guard

With the Gas Guard in operation, the incubator uses the gas supplied by the tank connected to Inlet #1 until pressure drops below 10 psig (0.690 bars). At this time, the Gas Guard automatically switches to gas supplied through CO<sub>2</sub> Inlet #2.

In addition, the incubator automatically changes Tank Sel in Configuration Mode from 1 to 2 to indicate that the incubator is now using gas supplied through Inlet # 2. If the gas supply to Inlet #1 is replenished, the incubator continues to operate using the gas supplied through Inlet #2 unless the operator changes Tank Sel from #2 to #1 through Configuration Mode. Refer to Section 3, Configuration.



## Operation of CO<sub>2</sub> Gas Guard (continued)

Audible and visual alarms occur on the control panel when the gas guard switches from one supply to the other. The audible alarm sounds until the operator presses the Silence key on the control panel. The visual alarm in the Message Center reads 'Tank 1 Low' while the audible alarm is sounding, but the message is removed when the operator presses the Silence key. However, the 'Tank Low' indicator on the control panel stays lit until the condition is resolved. The unit operates normally.

**Caution** Both the audible and visual alarms described above do not ring back once the Silence key is pressed. ▲

If the Gas Guard system does not detect an adequate gas supply at CO<sub>2</sub> Inlet #1 or Inlet #2, a visual and audible alarm again occurs on the control panel. The visual alarm in the Message Center reads 'Tank 1&2 Low'. The audible alarm continues to ring until the Silence key is pressed. The audible alarm rings back every 15 minutes after the alarm is silenced, if the Gas Guard continues to detect that both gas supply pressures are below 10 psig (0.690 bars).

## Inner Doors

Align the shelves and shelf channels with each of the inner doors to facilitate introduction and removal of trays. Clean these doors with the same care as the single door. See Section 5.

## Shaker Support Shelves

Shaker support shelves are reinforced and secured to the walls of the incubator. They have a load limit of (1) shaker or 200 pounds per shelf, one shelf being the floor of the unit. The shaker platform limit is 50 pounds. Shakers must not exceed 250 rpm when used inside this incubator. For shaker power connection, an internal outlet in the upper right corner of the back wall is installed. Casters are installed at the factory for moving the cabinet to the desired location. After the unit is in place and prior to operation, the casters must be removed. The large rubber vibration feet, factory installed, are positioned correctly for operation. Do not adjust.

**Caution** Any equipment placed inside the chamber must be rated for unit operating temperature and humidity. ▲

## Section 7 Specifications

*\* Specifications are based on nominal voltages of 115V or 230V in ambient temperature of 22°C to 25°C.*

### Temperature

Control . . . . . ±0.1°C Microprocessor PID  
Setpoint . . . . . Digital – Touch Pad, 0.1°C  
Range . . . . . +5°C above ambient to 60°C  
Uniformity . . . . . ±0.3°C @ +37°C  
Tracking Alarm. . . User programmable (low) indicator  
Overtemp . . . Tracking, user programmable, action and indicator  
Display . . . . . Digital, LED, 0.1°C increments

### Temperature Safety

Type . . . Extreme temperature safety, action and indicator  
Sensor . . . Thermostat, independent of temperature control system  
Indicator . . Message center, audible and visual alarms

### Relative Humidity

Selectable Ranges . . Medium (>80%), High (>90%)

### CO<sub>2</sub>

Control: . . . . . ±0.1% microprocessor PID  
Sensor: . . . . . Thermal conductivity  
Readability: . . . . . 0.1%  
Range: . . . . . 0 to 20%  
Inlet Pressure: . . . . . 15 PSIG (±5 PSIG)  
Display: . . . . . Digital LED, 0.1% increments

Shelves

Dimensions . . .30.62” W x 25.81” F-B (77.78 cm x 65.56 cm)  
Construction: . . . . .Solid stainless steel, 2B finish  
Surface Area . . . . .5.4 sq. ft (0.51 sq. m) per shelf  
Max per Chamber: . . . . .145.8 sq. ft (13.55 sq. m)  
Standard: . . . . .5  
Maximum: . . . . .27  
Clearance: . . . . .Adjustable on 2” (5 cm) centers

Construction

Interior volume . . . . .29 cu ft (823 liters)  
Interior . . . . .304 stainless steel, 2B finish  
Exterior . . . . .18-gauge cold rolled steel  
Exterior Door . . .Heated, triple pane tempered glass  
Outer Door Gasket . . . . .Molded vinyl  
Insulation . . . . .2” fiberglass

Fittings

Access Port . . . .2.4” (6.1 cm) ID, one port per side  
CO<sub>2</sub> Inlet . . . . .1/4” barbed  
Sample Port . . . . .Front mount, 1/4” barbed  
Water Inlet . . . . .1/4” MPT for automatic fill  
Overflow Drain . . . . .3/8” MPT  
Condensate Drain . . . . .3/8” FPT

Electrical

Model 3950:100-120VAC, 50/60Hz, 1 PH, 10.0 FLA  
Operating Range, including fluctuations - 90-125V, 50-60Hz,  
15A Breaker power switch  
Model 3951:200-230VAC, 50/60Hz, 1 PH, 6.0 FLA  
Operating Range, including fluctuations - 180-250V, 50-60Hz,  
8A Breaker power switch  
Power Switch . . . . .2-pole circuit breaker  
Accessory Outlet . . . Voltage equal to the cabinet input, 75W max.,  
0.5mA leakage current  
Interior Outlet . . . . Voltage equal to cabinet input, 230W max,  
0.5mA leakage current  
Remote Alarm Contacts . . . Deviation of temperature, CO<sub>2</sub> & power.  
N.O. & N.C.

Unit BTU Output

115V/230V: .....510 BTUH (150W)

Dimensions

Exterior .....38.0" W x 80.0" H x 33.0" F-B  
(96.5 cm x 203.2 cm x 83.8 cm)

Interior .....31.0" W x 60.0" H x 27.0" F-B  
(78.7 cm x 152.4 cm x 68.6 cm)

Weight .....500 lbs. (226.8 kg)

Certification

3950 Series - UL, CSA, CE

3951 Series – CSA, CE

Safety Specifications

Altitude: .....2,000 meters

Temperature: .....5°C to 40°C

Humidity .....80% RH at or below 31°C,  
decreasing linearly to 50% RH at 40°C

Mains Supply Fluctuations . . .Operating Voltage Range

Installation Category II

Pollution Degree 2

Class of Equipment I

---

1 Installation category (overvoltage category) defines the level of transient overvoltage which the instrument is designed to withstand safely. It depends on the nature of the electricity supply and its overvoltage protection means. For example, in CAT II which is the category used for instruments in installations supplied from a supply comparable to public mains such as hospital and research laboratories and most industrial laboratories, the expected transient overvoltage is 2500V for a 230V supply and 1500V for a 120V supply.

---

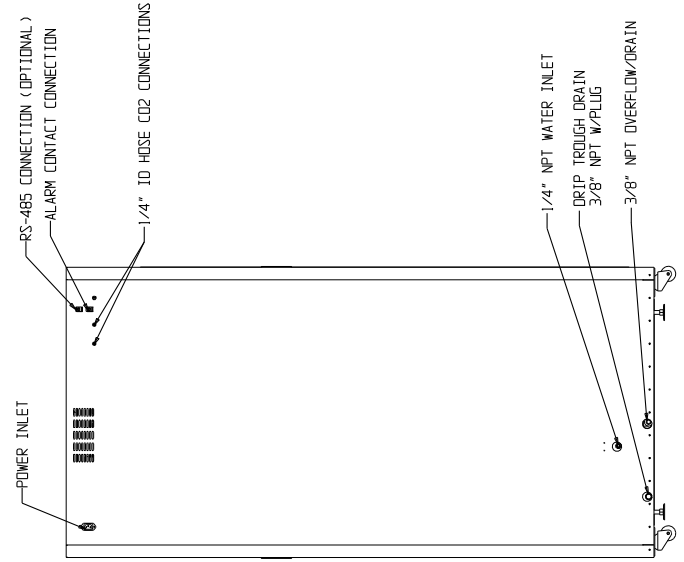
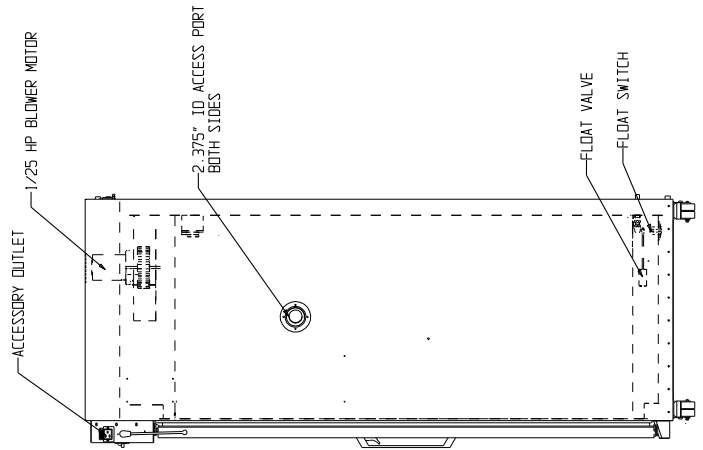
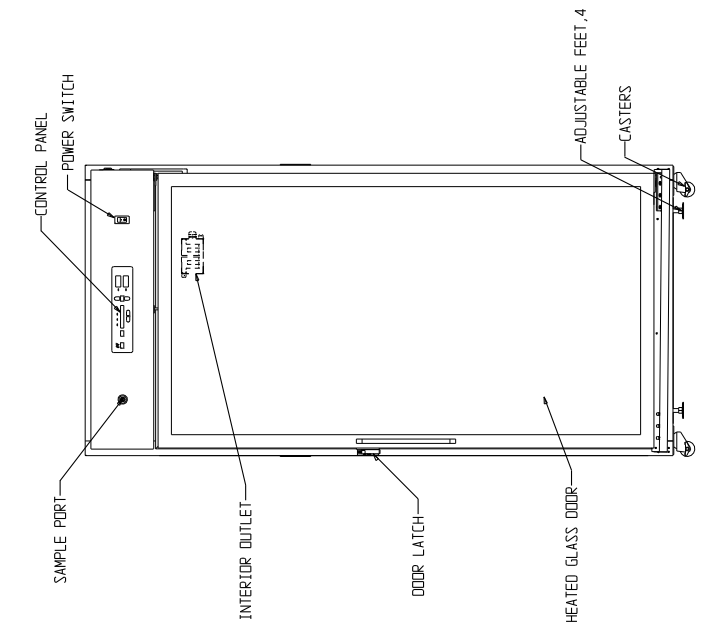
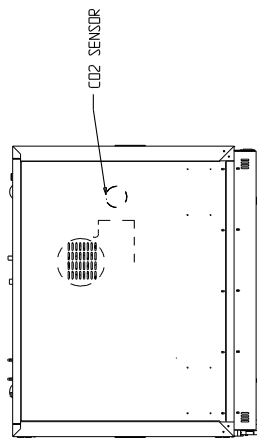
2 Pollution degree describes the amount of conductive pollution present in the operating environment. Pollution degree 2 assumes that normally only non-conductive pollution such as dust occurs with the exception of occasional conductivity caused by condensation.



## Section 8 Spare Parts

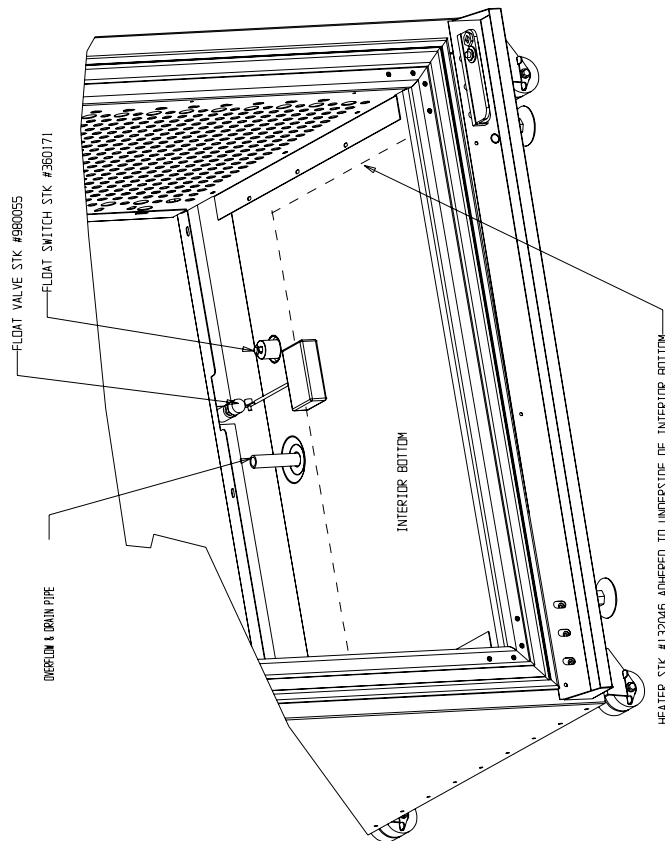
<b>Part Number</b>	<b>Description</b>
230135	1 amp fuse (3950 accessory outlet)
230158	2.5 amp fuse (3950 interior outlet)
230120	0.5 amp fuse (3951 accessory outlet)
230106	1.5 amp fuse (3951 interior outlet)
156112	Blower motor 1/30th HP
170164	Motor capacitor 3 MFD, 370VAC
600210	300 watt wire-wound heater
250118	CO <sub>2</sub> solenoid 12V DC
360157	Door switch
1900471	Add Water float switch with pins
290138	Temperature control sensor
191563	Microprocessor board
290090	CO <sub>2</sub> sensor
400119	Power supply
190641	Gas guard manifold with pressure switches & valve
980055	Float valve assembly, 100 PSI
515080	Leveler, 2" diameter
227083	Door latch assembly
770001	Inline CO <sub>2</sub> filter
600034	0.375" hose clamp
950013	1/4" vinyl tubing for CO <sub>2</sub> connection
505071	Stainless steel shelf
190012	Stainless steel shelf channel
180006	0 - 60°C chart paper, 1 pen recorder
197075	0 - 100°C chart paper, 2 pen recorder
190467	3/8" MPT x 3/8" tube P-trap
380177	3/8" FPT brass elbow
130096	Ionic Silver Stick

**Section 8**  
Spare Parts



REV	ECN NO.	DATE	BY	CAD APPD	DESCRIPTION OF REVISION
0	N/A	6/22/99	DCB	DCB/MAH	RELEASE FOR PRODUCTION
1	IN-2740	9/29/99	DCB	DCB/CCS	DATE Dwg. & STK'S WAS 350-07-3

DWG. NUMBER: 350-01-1-B



THIS DOCUMENT CONTAINS PROPRIETARY INFORMATION AND SUCH INFORMATION IS NOT TO BE DISCLOSED TO OTHERS FOR ANY PURPOSE NOR USED FOR MANUFACTURING PURPOSES WITHOUT WRITTEN PERMISSION FROM THERMO SCIENTIFIC.

**Thermo**  
Scientific  
Controlled Environment Equipment  
Box 661, Norwalk, CT 06856

MODEL/PART NAME: 350 REACH-IN INCUBATOR

DWG TITLE: INTERIOR BOTTOM VIEW

DWG DATE: CAD: DCB APPD: MAH DATE: 6/22/99 SCALE: 0:100

MATERIAL: WA

PAINT: WA

TOLERANCE UNLESS OTHERWISE SPECIFIED  
ANGLES: DECIMAL: .XX±  
ANGLES: DECIMAL: .XXX±

DRAWING NUMBER: 350-01-1

SIZE: B

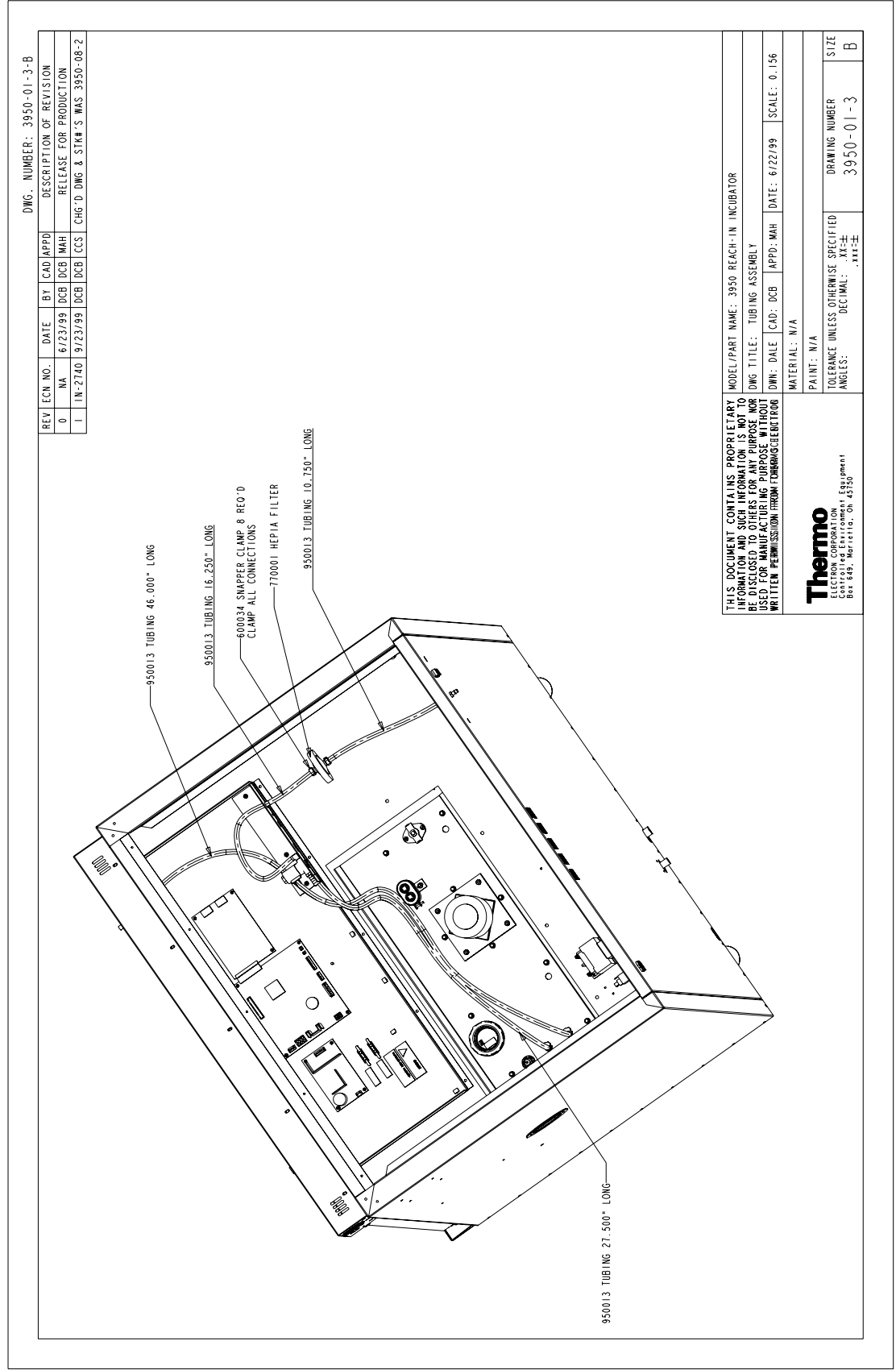


**Section 8**  
Spare Parts

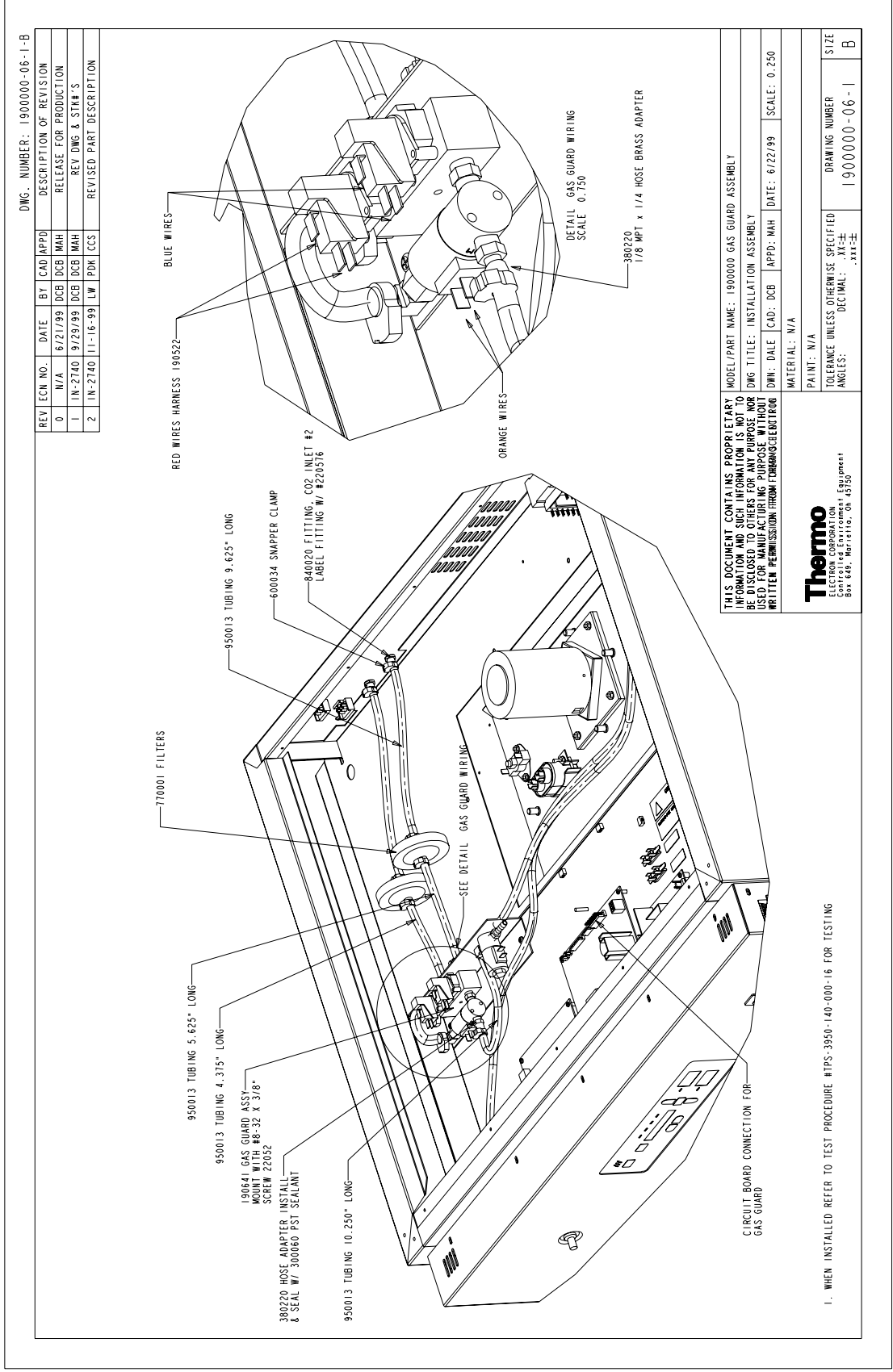
REV		ECN NO.	DATE	BY	CAD APPD	DESCRIPTION OF REVISION
0	N/A	6/29/99	DCB	DCB	MAH	RELEASE FOR PRODUCTION
1	IN-2740	9/27/99	DCB	DCB	CCS	DRG'D ING. & STR'S. WAS 390-07-5

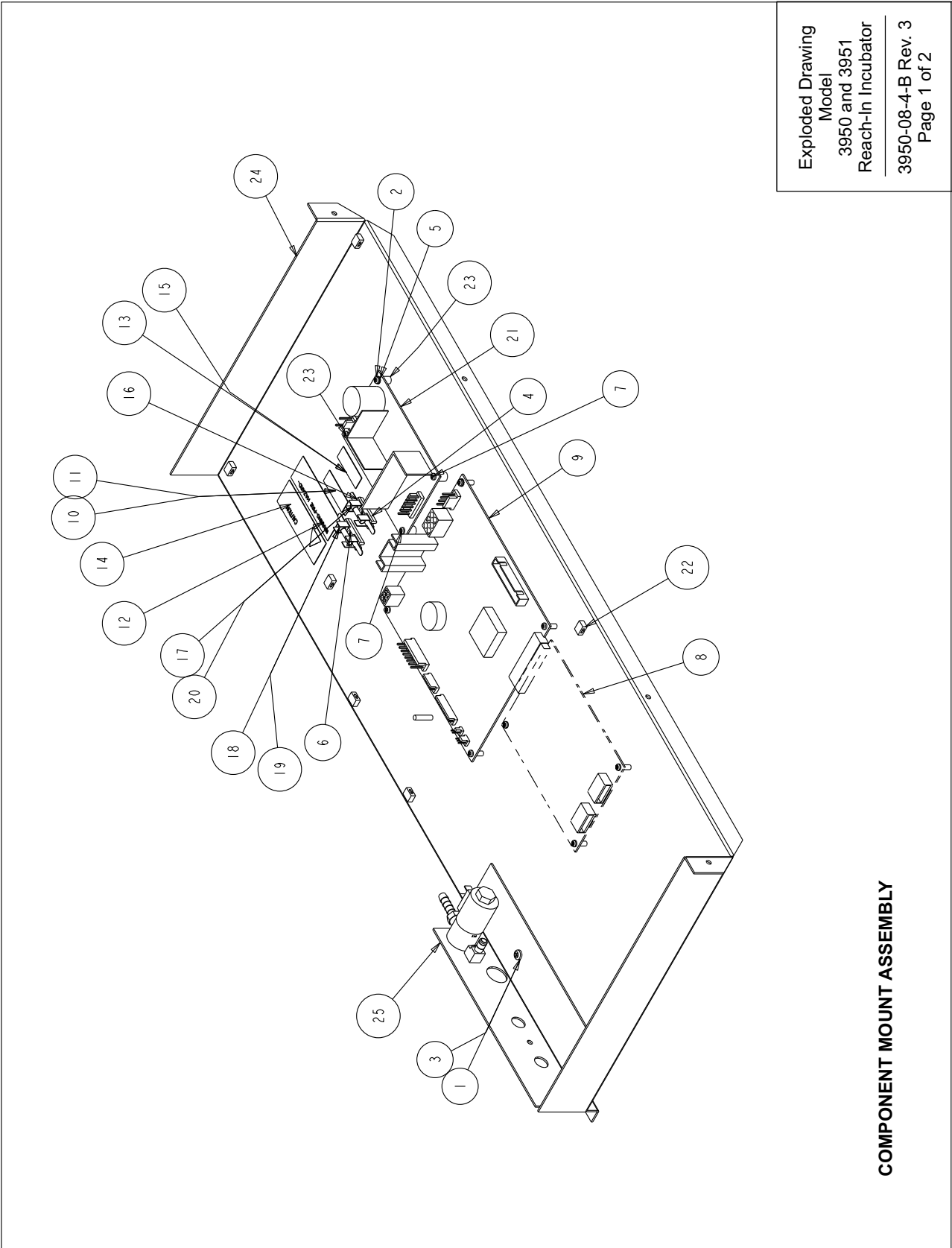
ING. NUMBER: 3950-01-2-B

MODEL/PART NAME: 3950 REACH-IN INCUBATOR	
ING TITLE: INTERIOR TOP VIEW	
DM: DATE	APPD: MAH
DATE: 6/22/99	SCALE: 0.188
MATERIAL: WA	
PAINT: N/A	
TOLERANCE: UNLESS OTHERWISE SPECIFIED	
ANGLES: .XX±	DECIMAL: .XXX±
DRAWING NUMBER	3950-01-2
SIZE	B



**Section 8**  
Spare Parts





Exploded Drawing  
Model  
3950 and 3951  
Reach-In Incubator  
3950-08-4-B Rev. 3  
Page 1 of 2

COMPONENT MOUNT ASSEMBLY

BILL OF MATERIALS				
ITEM NO.	PART NO.	PART DESCRIPTION	W/C	QTY
1	22052	#8-32 X 3/8 SS PHP SCREW		3
2	22130	#4-40 X 1/4 SS PHP SCREW		11
3	23002	#8-32 ZP LKWASH HEX NUT		3
4	23006	#4-40 ZP LKWASH HEX NUT		2
5	23029	#4 SS EXT TOOTH LOCKWASHER		2
6	59007	#4-40 X 3/8 SS PHP SCREW		2
7	125035	5/1600 X .192ID X 3/8L NYLON SPACER		2
8	190571	4-20MA ANALOG BOARD (OPTIONAL)		1
9	191563	3950 MICRO BOARD (3950 ONLY)		1
10	220359	1 AMP FUSE LABEL (3951 ONLY)		1
11	220378	.5 AMP LABEL		1
12	220437	FIRE HAZARD LABEL (3951 ONLY)		1
13	220439	1.5 AMP LABEL		1
14	220555	ESD LABEL (3950 ONLY)		1
15	220569	2.5 AMP FUSE LABEL		1
16	230105	FUSE BLOCK 5 X 22 MM(3951 ONLY)		2
17	230106	FUSE_1_5A_5X22MM (3951 ONLY)		1
18	230120	FUSE_..5A_5X22MM (3950 ONLY)		1
19	230135	FUSE_1A_5X22MM (3950 ONLY)		1
20	230158	FUSE_2_5A_5X22MM		1
21	400119	SWITCHER		1
22	440002	TIE WRAP PUSH-IN ANCHOR		6
23	515084	1/4 DIA. X 3/8L SS SPACER		2
24	1900006-17-3	COMPONENT MOUNT SUB-ASSY		1
25	3950-08-3	SOLENOID VALVE SUB-ASSY		1

Exploded Drawing  
Model  
3950 and 3951  
Reach-In Incubator  
3950-08-4-B Rev. 3  
Page 2 of 2

**COMPONENT MOUNT ASSEMBLY**

DWG. NUMBER: 3950-08-5-B

REV	ECN NO.	DATE	BY	CAD	APPD	DESCRIPTION OF REVISION
0	IN-2740	12-10-99	LW	PDK	ECS	RELEASED FOR PRODUCTION

BILL OF MATERIALS			
ITEM NO.	PART NO.	PART DESCRIPTION	W/C QTY
1	22053	#8-32 X 1/2 SS PHP SCREW	379 4
2	23010	#8-32 SS HEX NUT	379 4
3	23080	#8 SS SPRING LOCKWASHER	379 4
4	13018	TAPE	379 3
5	1900036	31-1 HEATER MOUNT	379 2
6	191593	BLKW	379 1
7	191593	LWTW	379 1
8	191593	REDW	379 1
9	191593	SWTW	379 1
10	600210	HTR WIREWOUND HEATER 300W 120V	379 2

THIS DOCUMENT CONTAINS PROPRIETARY INFORMATION AND SUCH INFORMATION IS TO BE DISCLOSED ONLY TO AGENTS AT OUR SALES OFFICE AND TO PERSONS ON OUR ACTIVE LISTING SERVICE. IN NO EVENT SHALL THIS DOCUMENT BE REPRODUCED OR TRANSMITTED IN ANY FORM OR BY ANY MEANS, ELECTRONIC OR MECHANICAL, WITHOUT PERMISSION FROM THERMO SCIENTIFIC.

**Thermo**  
Scientific  
Controlled Environment Equipment  
Box 649, Marietta, Oh 45750

MATERIAL	TOLERANCE UNLESS OTHERWISE SPECIFIED	DECIMAL	ANGLES	SCALE	DATE	APPD	DATE	SCALE	DRAWING NUMBER	SIZE
		.XXE-E	.XXXE-E	0.438	12-10-99	PDK	12-10-99	0.438	3950-08-5	B

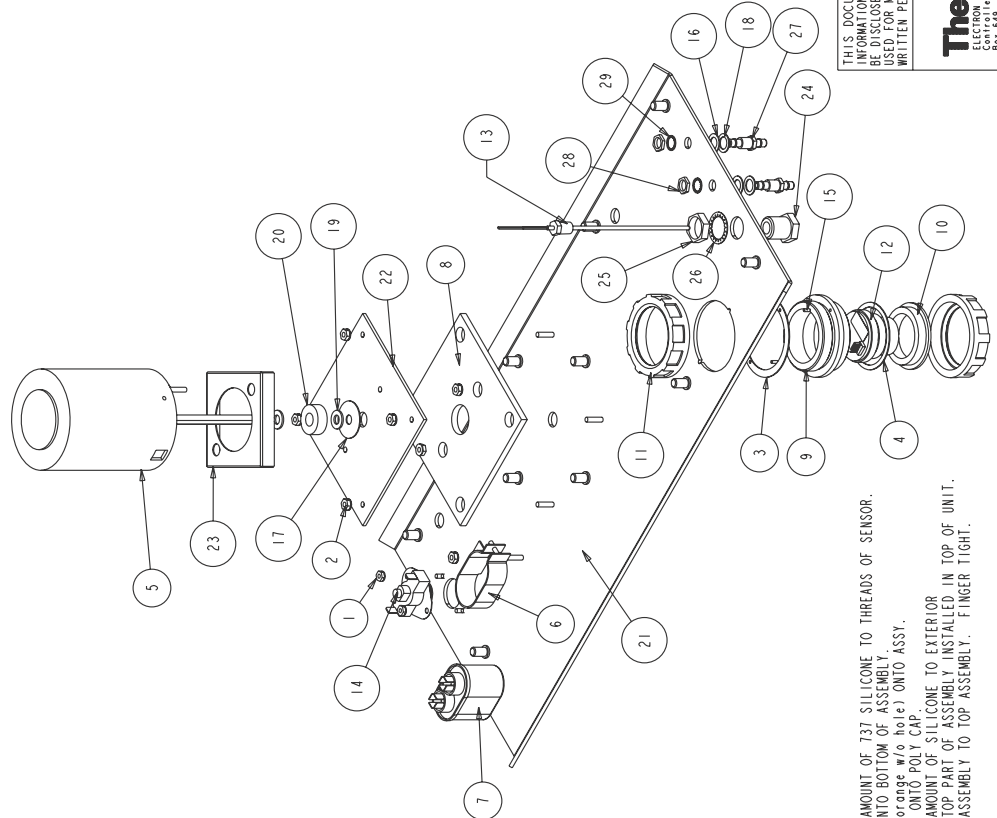
**Section 8**  
Spare Parts

DWG. NUMBER: 1900007-06-1-B

REV	ECN NO.	DATE	BY	ICAD	APPD	DESCRIPTION OF REVISION
1	1N-2140	07-02-99	DCB	IMH		ADDED PARTS PER V-RUN
2	1N-2140	09-22-99	DCB	DNF		CHG'D DWG & STRK'S (WAS 3950-07-1)
3	1N-2140	11-17-99	LW	KDG	LDN	ADDED PROCEDURE NOTES
4	1N-2140	12-08-99	PKK	LDN		REV. MOTOR SPACER PART NUMBER
5	1N-3320	08-07-06	JLN	NSE	CCS	CHG'D WASHERS IN SHFT TO ELIMINATE LEAKING

**BILL OF MATERIALS**

ITEM NO.	PART NO.	PART DESCRIPTION	W/C	QTY
1	23001	#6-32 ZP LKWASH HEX NUT		2
2	23002	#8-32 ZP LKWASH HEX NUT		7
3	103099	SENSOR MOUNT GASKET	N/A	1
4	103100	CO2 CELL ADAPTR GASKET	N/A	1
5	156112	1730 HP PSC MOTOR	N/A	1
6	170025	CAPASITOR MOUNT	N/A	1
7	170164	3MFD RUN CAPASITOR	N/A	1
8	190151	MTR MNT GASKET .250 X 5 X 5	N/A	1
9	190781	CO2 CELL MOUNT	N/A	1
10	190782	CO2 CELL ADAPTER	N/A	1
11	200125	2. INCH CONDUIT NUT		2
12	290090	TC CO2 SENSOR ASSY	N/A	1
13	290138	THERMISTOR PROBE ASSY	N/A	1
14	400141	60T15 THERMOSTAT 180F	N/A	1
15	640046	3/32 X 1/4 DOWEL PIN		2
16	730031	NEOPRENE WASHER		2
17	730055	.315" ID NYLON WASHER		2
18	730068	.310 ID TEFLON FLAT WASHER		2
19	730069	SILICONE WASHER	N/A	1
20	1900021-06-1	BLOWER MOUNT SUB-ASSY		1
21	1900022-31-1	BLOWER MNT PLATE	N/A	1
22	1900035-31-1	MOTOR SPACER	N/A	1
23	380502-FTG	.125 NPT X .75-20 BLKHD FTG	N/A	1
24	380502-NUT	.750 X 20 BLKHD FTG NUT	N/A	1
25	380502-WSHR	.750 INTL WASHER BLKHD FTG	N/A	1
26	840020-FTG	.250 BULKHEAD FITTING	N/A	2
27	840020-NUT	.375 NUT BLKHD FITTING	N/A	2
28	840020-WSHR	.375 TT WASHER BLKHD FTG	N/A	2
29	840020-WSHR	.375 TT WASHER BLKHD FTG	N/A	2



1. APPLY A SMALL AMOUNT OF 737 SILICONE TO THREADS OF SENSOR.
2. SCREW SENSOR ONTO BOTTOM OF ASSEMBLY.
3. PLACE GASKET (orange w/o hole) ONTO ASSY.
4. PLACE ASSEMBLY ONTO POLY CAP.
5. APPLY A SMALL AMOUNT OF SILICONE TO EXTERIOR OF THREADS ON TOP PART OF ASSEMBLY INSTALLED IN TOP OF UNIT.
6. SECURE BOTTOM ASSEMBLY TO TOP ASSEMBLY. FINGER TIGHT.

THIS DOCUMENT CONTAINS PROPRIETARY INFORMATION AND SUCH INFORMATION IS NOT TO BE DISCLOSED TO OTHERS FOR ANY PURPOSE NOR USED FOR MANUFACTURING PURPOSE WITHOUT WRITTEN PERMISSION FROM THERMO ELECTRON

MODEL/PART NAME: 3950 REACH-IN INCUBATOR  
 DWG TITLE: BLOWER MOTOR MOUNT ASSY  
 DWG: DALE | CAD: DCB | APPD: MAH | DATE: 2/20/99 | SCALE: 0.300

MATERIAL: -  
 PAINT: N/A  
 TOLERANCE UNLESS OTHERWISE SPECIFIED: .XX±  
 ANGLES: .XX±

**Thermo**  
 Scientific  
 Controlled Environment Equipment  
 Box 669, Marietta, Oh 45750

DRAWING NUMBER: 1900007-06-1  
 SIZE: B

DWG. NUMBER: 1900008-06-1-B

REV	ECN NO.	DATE	BY	CAD	APPD	DESCRIPTION OF REVISION
2	IN-2740	11/17/99	LW	PKD	LON	ADDED 110008 BLK VINYL CAP
3	IN-2740	12-09-99	LW	PKD	LON	ADDED 730017 FIBER WASHER
4	IN-2808	06-27-00	WLG	KDG	LON	CHANGED 51594 SS STANDOFFS TO 127071 ALUM
5	PIP-029	08-28-01	WCW	PKD	LON	REVISED OUTLET MOUNT
6	IN-3019	02-15-02	WCW	PKD	LCCS	CHANGED FROM 22115 & 23030 TO 590027

**BILL OF MATERIALS**

ITEM NO.	PART NO.	PART DESCRIPTION	W/C	QTY
1	22049	#6-32 X 3/8 SS PHP SCREW		2
2	22051	#8-32 X 1/4 SS PHP SCREW		4
3	23002	#8-32 ZP LKWASH HEX NUT		5
4	23021	#8 SS FLAT WASHER		8
5	23059	#8 SS EXT TOOTH LOCKWASHER		4
6	110008	BLACK VINYL CAP		1
7	127071	#8-32 X 9/16L ALUM HEX STANDOFF		4
8	189896	DOOR HEATER HARNESS		1
9	190609	INCUBATOR CP ASSEMBLY		1
10	190994	ACCESSORY OUTLET MOUNT		1
11	194021	7" LONG 34 POS CABLE		1
12	220259	ACCESS OUTLET LABEL		1
13	230178	8 A DPDT RKR CB/SWITCH		1
14	230184	15A DPDT RKR CB/SWITCH		1
15	360157	Momentary Rocker Switch SPDT		1
16	460024	SNAP-IN OUTLET, WHITE		1
17	460138	POWER OUTLET		1
18	590027	#6-32 X 1/4 SS PHP EXT SEMS SCREW		6
19	730017	3/8 BLACK FIBER WASHER		1
20	1900008-16-1	CONTROL PANEL SUB-ASSEMBLY		1
21	1900016-16-1	OVERLAY MOUNT SUB-ASSEMBLY	N/A	1
22	190615-31-1	CONTROL PANEL BRACE & COVER	N/A	1
23	840020.FTG	.250 BULKHEAD FITTING	N/A	1
24	840020.NUT	.375 NUT BLKHD FITTING	N/A	1
25	840020.WSHR	.375 1T WASHER BLKHD FITG	N/A	1

**Thermo**  
ELECTRON CORPORATION  
Controlled Environment Equipment  
Box 649, Marietta, OH 45750

THIS DOCUMENT CONTAINS PROPRIETARY INFORMATION AND SUCH INFORMATION IS NOT TO BE DISCLOSED TO OTHERS FOR ANY PURPOSE NOR USED FOR MANUFACTURING PURPOSE WITHOUT WRITTEN PERMISSION FROM THERMO ELECTRON CORPORATION

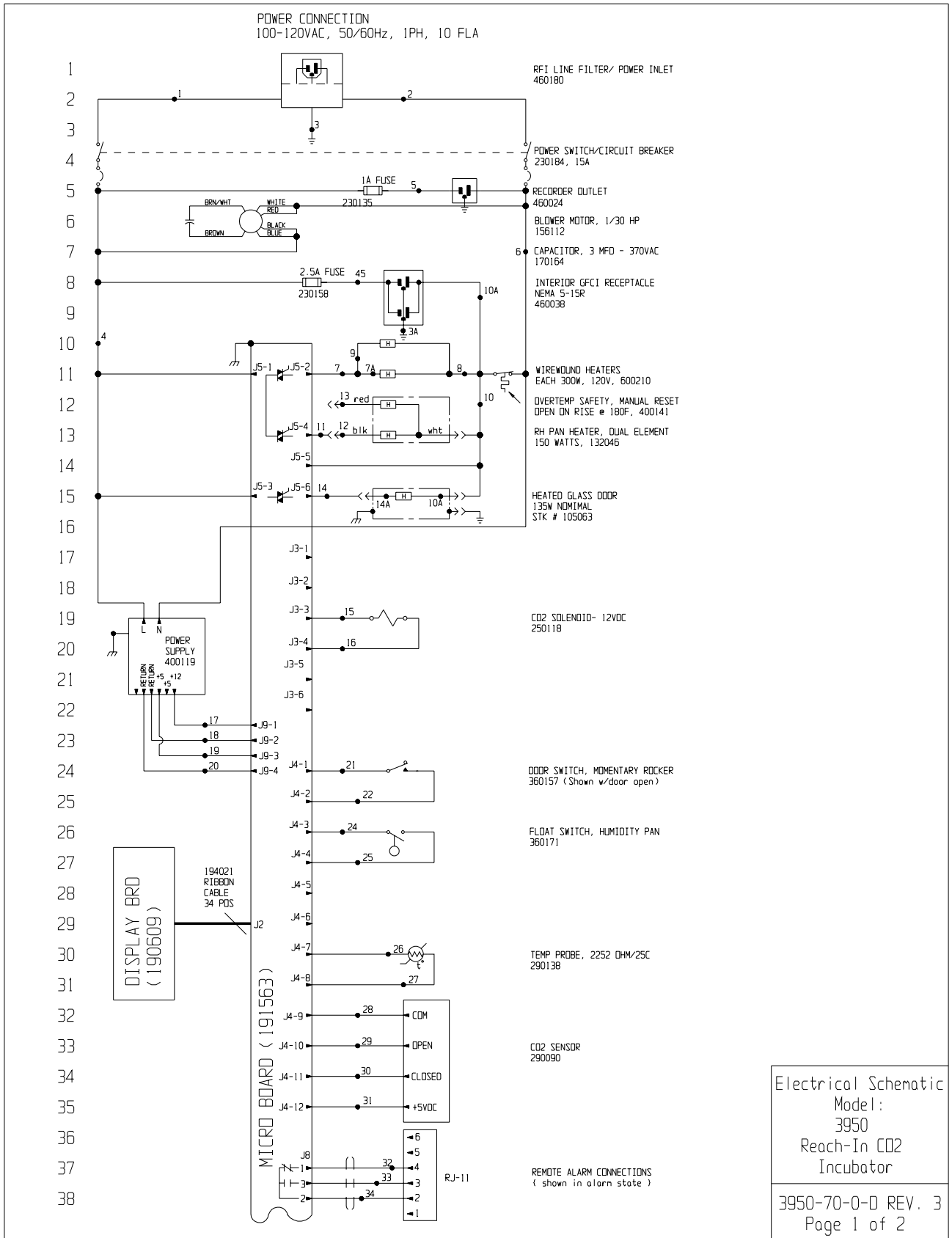
MODEL/PART NAME: REACH-IN INCUBATOR CONTROL PANEL STK #1900008  
DWG TITLE: CONTROL PANEL ASSEMBLY (3950, 3951)  
DWG: DALE CAD: DCB APPD: MAH DATE: 5/25/99 SCALE: 0.250  
MATERIAL: N/A  
PAINT: N/A  
TOLERANCE UNLESS OTHERWISE SPECIFIED DECIMAL: .XX±  
ANGLES: .XXX±

DRAWING NUMBER: 1900008-06-1  
SIZE: B

2- INSTALL OUTLET GREEN WIRE TO #8-32 CORNER STUD W/KEPS NUT  
1. TAP .106 HOLES (4 EACH) #6-32



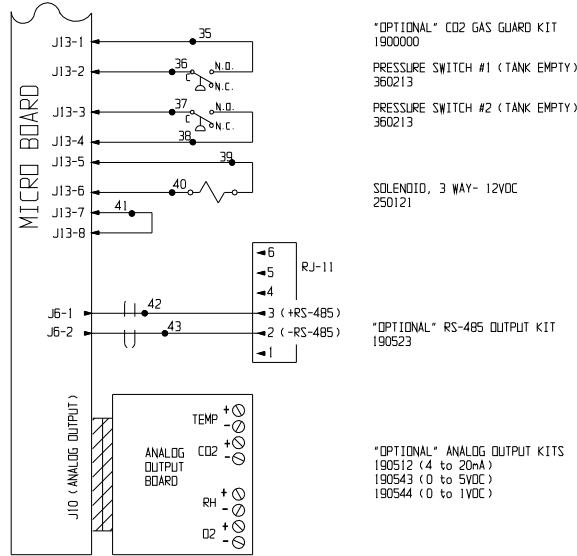




Electrical Schematic  
Model:  
3950  
Reach-In CO2  
Incubator  
3950-70-0-D REV. 3  
Page 1 of 2

**Section 9**  
Electrical Schematics

39  
40  
41  
42  
43  
44  
45  
46  
47  
48  
49  
50  
51  
52  
53  
54  
55  
56  
57  
58  
59  
60  
61  
62  
63  
64  
65  
66  
67  
68  
69  
70  
71  
72  
73

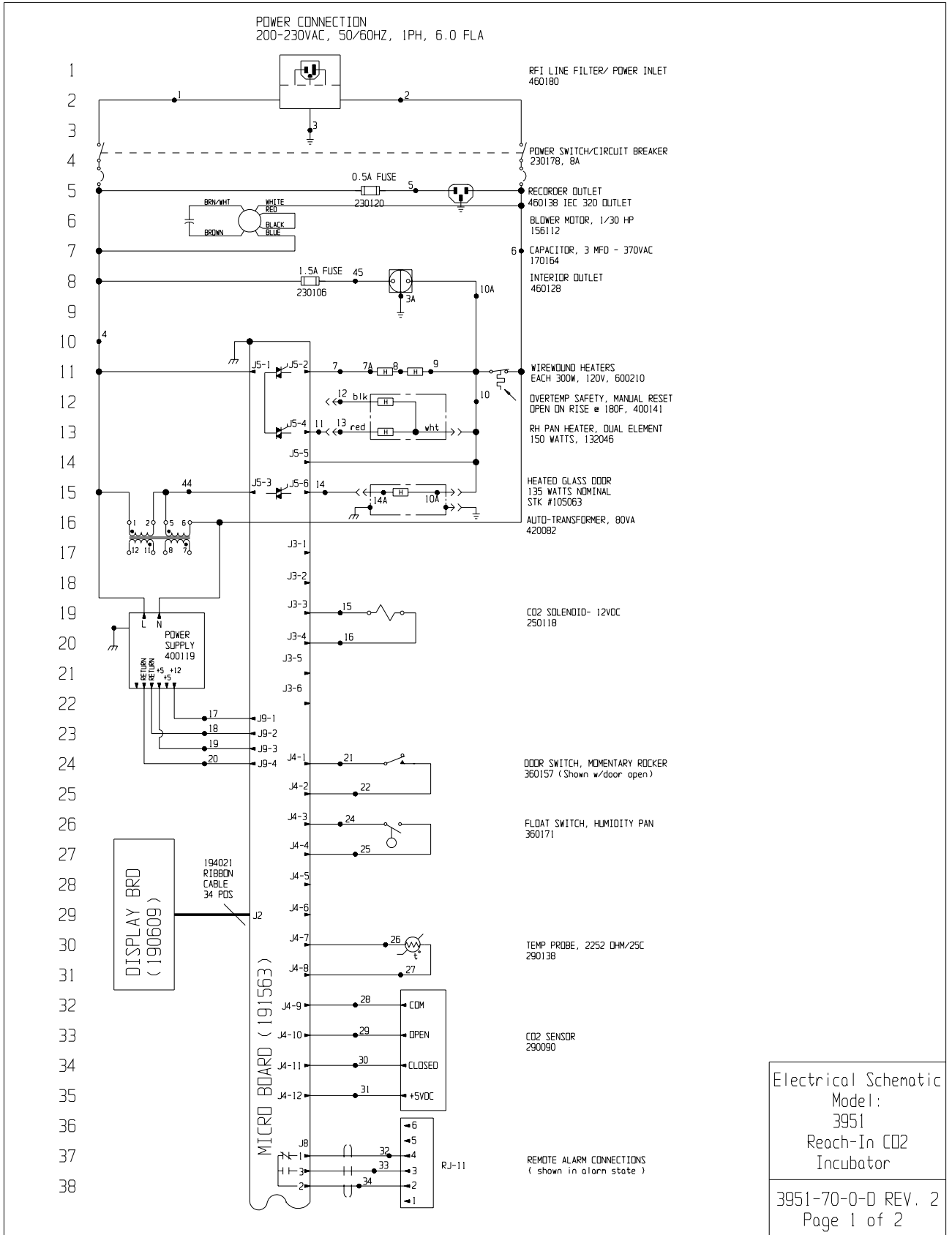


WIRE REFERENCE CHART								
NO.	GA.	COLOR	NO.	GA.	COLOR	NO.	GA.	COLOR
1	16	BROWN	21	22	BLUE	42	22/2	RED
2	16	BLUE	22	22	BLUE	43	22/2	BLACK
3	16	GRN-YEL	23					
3A	18	BLACK	24	22	BROWN	45	18	RED
4	16	BLACK	25	22	BROWN			
4A	18	YELLOW	26	22	RED			
5	18	BLACK	27	22	RED			
6	16	WHITE	28	22	GREEN			
7	18	ORANGE	29	22	GRAY			
7A	16	BLACK	30	22	PURPLE			
8	16	WHITE	31	22	ORANGE			
9	16	RED	32	22/3	BLACK			
10	16	GRAY	33	22/3	RED			
10A	18	WHITE	34	22/3	WHITE			
11	18	BLUE	35	20	RED			
12	18	BLACK	36	20	RED			
13	18	RED	37	20	BLUE			
14	18	BROWN	38	20	BLUE			
15	18	YELLOW	39	20	ORANGE			
16	18	YELLOW	40	20	ORANGE			
17	18	RED	41	20	BLACK			
18	18	GREEN						
19	18	ORANGE						
20	18	GREEN						

SENSOR REFERENCE VALUES  
 CO2 (290090) DIFFERENCE VOLTAGE OF 3-6MV/CO2  
 J4-9 & J4-10 TO J4-9 & J4-11

<b>NOTES:</b> Ⓞ Denotes Terminal Strip Connection N/A Lost Relay Number N/A Lost Terminal Number 45 Lost Wire Number	CUSTOMER APPROVAL/REFERENCE APPROVED BY _____ DATE OF APPROVAL _____ THIS DOCUMENT CONTAINS PROPRIETARY INFORMATION AND SUCH INFORMATION IS NOT TO BE DISCLOSED TO OTHERS FOR ANY PURPOSE NOR USED FOR MANUFACTURING PURPOSES WITHOUT WRITTEN PERMISSION FROM THERMO FORMA	3	IN-3038	07-01-02	RLM	KDG	CCS	CHG. 285758 OUTLET TO 460038 GFI	Electrical Schematic Model: 3950 Reach-In CO2 Incubator
		2	IN-2869	11-14-00	GJG	GJG	MSB	REVISED OODR NOTE	
1	IN-2717	07-14-99	GLM	PDK	M.H.		CORRECT TEMP. PROBE NUMBER		
0	N/A	04-22-99	GJG	GJG	M.H.		RELEASED FOR PRODUCTION		
REV ECN NO. DATE BY CAD APPD DESCRIPTION OF REVISION DATE 03-18-99 DWN GJG CAD GJG APPM.H. SCALE N/A CUSTOMER MODEL 3950 JOB TITLE REACH-IN INCUBATOR 115 VOLT (DOM.) DWG TITLE ELECTRICAL SCHEMATIC LOCATION JOB NUMBER DRAWING NUMBER INCUBATR GJG 3950-70-0-D		3950-70-0-D REV. 3 Page 2 of 2							

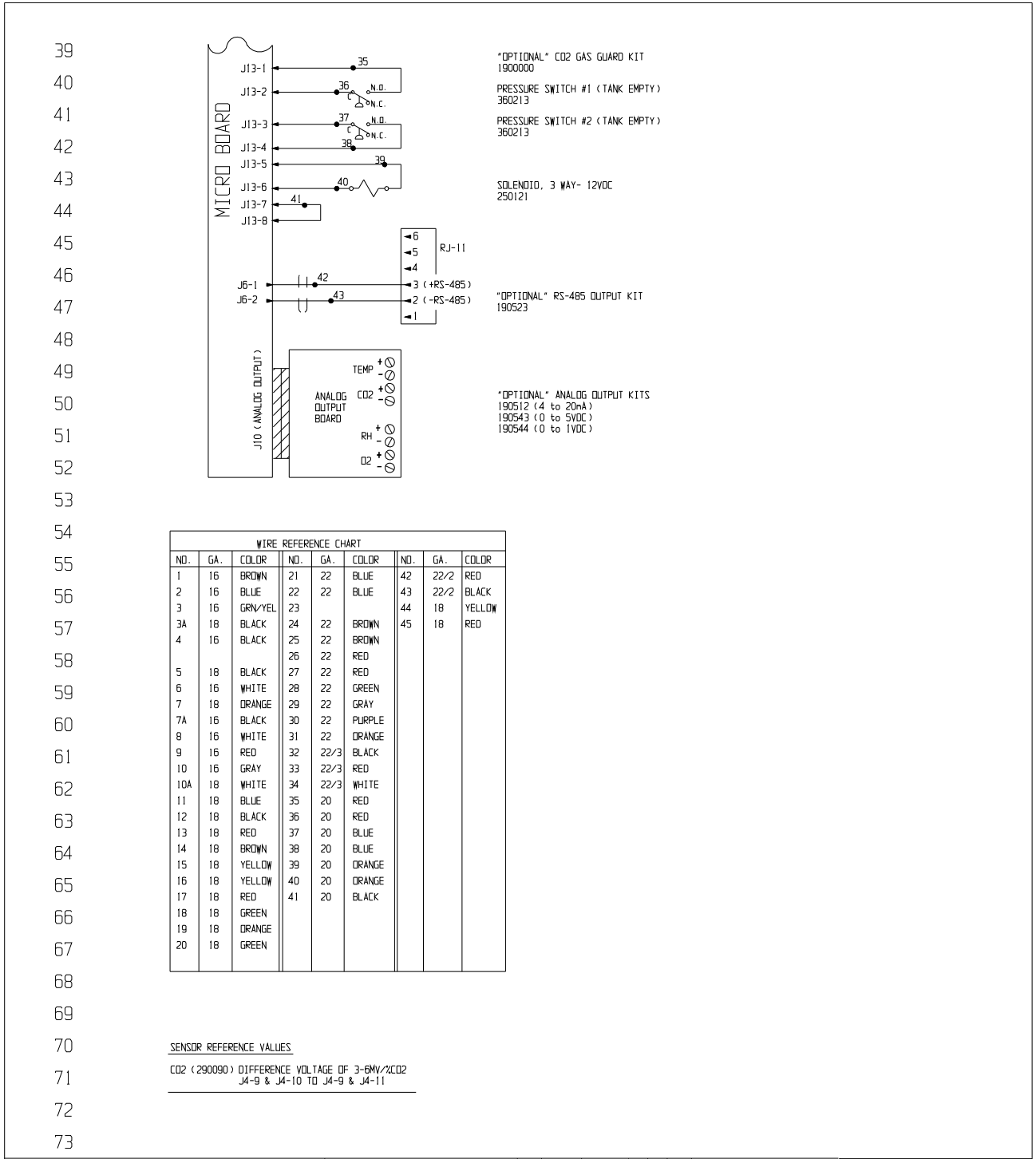




Electrical Schematic  
Model:  
3951  
Reach-In CO2  
Incubator

3951-70-0-0 REV. 2  
Page 1 of 2

**Section 9**  
Electrical Schematics



WIRE REFERENCE CHART								
NO.	GA.	COLOR	NO.	GA.	COLOR	NO.	GA.	COLOR
1	16	BROWN	21	22	BLUE	42	22/2	RED
2	16	BLUE	22	22	BLUE	43	22/2	BLACK
3	16	GRN/YEL	23			44	18	YELLOW
3A	18	BLACK	24	22	BROWN	45	18	RED
4	16	BLACK	25	22	BROWN			
			26	22	RED			
5	18	BLACK	27	22	RED			
6	16	WHITE	28	22	GREEN			
7	18	ORANGE	29	22	GRAY			
7A	16	BLACK	30	22	PURPLE			
8	16	WHITE	31	22	ORANGE			
9	16	RED	32	22/3	BLACK			
10	16	GRAY	33	22/3	RED			
10A	18	WHITE	34	22/3	WHITE			
11	18	BLUE	35	20	RED			
12	18	BLACK	36	20	RED			
13	18	RED	37	20	BLUE			
14	18	BROWN	38	20	BLUE			
15	18	YELLOW	39	20	ORANGE			
16	18	YELLOW	40	20	ORANGE			
17	18	RED	41	20	BLACK			
18	18	GREEN						
19	18	ORANGE						
20	18	GREEN						

SENSOR REFERENCE VALUES  
CO2 (290090) DIFFERENCE VOLTAGE OF 3-6MV/%CO2  
J4-9 & J4-10 TO J4-9 & J4-11

NOTES: 74 Denotes Terminal Strip Connection N/A Last Relay Number N/A Last Terminal Number 45 Last Wire Number	CUSTOMER APPROVAL/REFERENCE APPROVED BY _____ DATE OF APPROVAL _____				Electrical Schematic Model: 3951 Reach-In CO2 Incubator
	THIS DOCUMENT CONTAINS PROPRIETARY INFORMATION AND SUCH INFORMATION IS NOT TO BE DISCLOSED TO OTHERS FOR ANY PURPOSE NOR USED FOR MANUFACTURING PURPOSES WITHOUT WRITTEN PERMISSION FROM FORMA SCIENTIFIC		2 IN-2869 11-14-00 GJG GJM CCS 1 IN-2717 07-14-99 GLM PDK MSB 0 N/A 04-22-99 GJM M.H.	REV ECN NO. DATE BY CAD APPD DESCRIPTION OF REVISION DATE 03-18-99 DWN GJM CAD GJM APPDM.H. SCALE N/A CUSTOMER MODEL 3951 JOB TITLE REACH-IN INCUBATOR 230 VOLT (EXP.) DWG TITLE ELECTRICAL SCHEMATIC LOCATION JOB NUMBER DRAWING NUMBER INCUBATR 3951-70-0-D	

## THERMO FISHER SCIENTIFIC STANDARD PRODUCT WARRANTY

The Warranty Period starts two weeks from the date your equipment is shipped from our facility. This allows for shipping time so the warranty will go into effect at approximately the same time your equipment is delivered. The warranty protection extends to any subsequent owner during the first year warranty period.

During the first year, component parts proven to be non-conforming in materials or workmanship will be repaired or replaced at Thermo's expense, labor included. Installation and calibration are not covered by this warranty agreement. The Technical Services Department must be contacted for warranty determination and direction prior to performance of any repairs. Expendable items, glass, filters and gaskets are excluded from this warranty.

Replacement or repair of components parts or equipment under this warranty shall not extend the warranty to either the equipment or to the component part beyond the original warranty period. The Technical Services Department must give prior approval for return of any components or equipment. At Thermo's option, all non-conforming parts must be returned to Thermo Fisher Scientific postage paid and replacement parts are shipped FOB destination.

**THIS WARRANTY IS EXCLUSIVE AND IN LIEU OF ALL OTHER WARRANTIES, WHETHER WRITTEN, ORAL OR IMPLIED. NO WARRANTIES OF MERCHANTABILITY OR FITNESS FOR A PARTICULAR PURPOSE SHALL APPLY.** Thermo shall not be liable for any indirect or consequential damages including, without limitation, damages relating to lost profits or loss of products.

Your local Thermo Sales Office is ready to help with comprehensive site preparation information before your equipment arrives. Printed instruction manuals carefully detail equipment installation, operation and preventive maintenance.

If equipment service is required, please call your Technical Services Department at 1-800-438-4851 (USA and Canada) or 1-740-373-4763. We're ready to answer your questions on equipment warranty, operation, maintenance, service and special application. Outside the USA, contact your local distributor for warranty information.



Rev. 4 4/09

## **THERMO FISHER SCIENTIFIC INTERNATIONAL DEALER WARRANTY**

The Warranty Period starts two months from the date your equipment is shipped from our facility. This allows for shipping time so the warranty will go into effect at approximately the same time your equipment is delivered. The warranty protection extends to any subsequent owner during the first year warranty period. Dealers who stock our equipment are allowed an additional six months for delivery and installation, provided the warranty card is completed and returned to the Technical Services Department.

During the first year, component parts proven to be non-conforming in materials or workmanship will be repaired or replaced at Thermo's expense, labor excluded. Installation and calibration are not covered by this warranty agreement. The Technical Services Department must be contacted for warranty determination and direction prior to performance of any repairs. Expendable items, glass, filters, reagents, tubing, and gaskets are excluded from this warranty.

Replacement or repair of components parts or equipment under this warranty shall not extend the warranty to either the equipment or to the component part beyond the original warranty period. The Technical Services Department must give prior approval for return of any components or equipment. At Thermo's option, all non-conforming parts must be returned to Thermo postage paid and replacement parts are shipped FOB destination.

**THIS WARRANTY IS EXCLUSIVE AND IN LIEU OF ALL OTHER WARRANTIES, WHETHER WRITTEN, ORAL OR IMPLIED. NO WARRANTIES OF MERCHANTABILITY OR FITNESS FOR A PARTICULAR PURPOSE SHALL APPLY.** Thermo shall not be liable for any indirect or consequential damages including, without limitation, damages relating to lost profits or loss of products.

Your local Thermo Sales Office is ready to help with comprehensive site preparation information before your equipment arrives. Printed instruction manuals carefully detail equipment installation, operation and preventive maintenance.

Contact your local distributor for warranty information. We're ready to answer your questions on equipment warranty, operation, maintenance, service and special application.



Rev. 4 2/09

# CE Declaration of Conformity

**Manufacturer:** Thermo Fisher Scientific (Asheville) LLC  
401 Millcreek Road  
Marietta Ohio 45750  
U.S.A.

hereby declares under its sole responsibility that the following product(s)

**Product Description:** Reach-In Laboratory Incubators

Cat. No.	Model No.	Release Level(s)	Year of Initial Marking	Cat. No.	Model No.	Release Level(s)	Year of Initial Marking
3950	3950	1 & 2	1999	3960	3960	2	1999
3951	3951	1 & 2	1999	3961	3961	2	1999

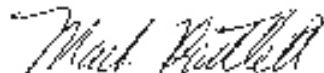
(Release Level [REL#] shown on serial tag)

This product conforms to the following European Union Directive(s):

**EMC:** 2004/108/EC  
**LVD:** 2006/95/EC

This product conforms to the following Harmonized, International and National Standards:

<b>EMC:</b>	<b>LVD:</b>
EN 50081-1	EN 61010-1
EN 55022	CAN/CSA C22.2 No. 1010.1
EN 61326-1	UL 61010-1 2 <sup>nd</sup> Edition
EN61000-3-2 & -3	UL 61010-2-010
EN 50082-1	
EN 61000-4-2 thru -8, -8 & -11	



19 January 2012

Mark Bartlett  
Supervisor, EPD

**ThermoFisher**  
**SCIENTIFIC**

Rev. 4





Thermo Fisher Scientific  
401 Millcreek Road  
Marietta, Ohio 45750  
United States

[www.thermofisher.com](http://www.thermofisher.com)