



**Technical Data Sheet**  
**Revco™ Ultra-Low Temperature Freezer**  
 Upright Model Release - 82  
 Thermo Fisher Scientific, Asheville, North Carolina

**Model Number**

RDE50040FV

**Application, Rating and Electrical Data**

|                          |  |
|--------------------------|--|
| Application              | Storage of General (non-flammable) Laboratory Materials  |
| Storage Volume           | 24.1 cu. ft. (682 liters), 500 Standard 2" Boxes   |
| Temperature Rating       | -10°C to -40°C   |
| Electrical Power         | 230V, 50 Hz, 1 Phase   |
| Instrument Rated Current | 3.4 AMP  |
| Building Supply Rating   | 10.0A (min) dedicated grounded circuit   |
| Power Plug / Power Cord  | Country Dependant plug / IEC Cords, 10 ft (3.05 m)   |
| Agency Listings          | UL, cUL, CE  |
| Application Environment  | Non-Corrosive, Non-Flammable, Non-Explosive<br>Indoor Use Only, Ventilated 15° C - 32° C (59° F - 90° F) |

**Typical Performance Characteristics in 20 °C Ambient**

|  |             |
|--|-------------|
| Energy Consumption (kW-hr/day)               | 5.3         |
| Heat Rejection Rate (Btu/hr)                 | 747         |
| Peak Variation from Setpoint (°C)            | +1.8 / -2.2 |
| Sound (dBA)                                  | 50.7        |
| 1-min Door Opening Recovery to -38.5°C (min) | 22          |
| Average Uniformity at -40°C (°C)             | 2.1         |
| Average Stability at -40°C (°C)              | 1.4         |
| Pull Down Time (to -40°C) (hrs)              | 2.4         |
| Warm Up Time (-40°C to -20°C) (min)          | 328         |

**Dimensions and Construction**

|                                 |  |
|---------------------------------|--|
| Interior Dimensions (H x D x W) | 51.2 x 28.3 x 28.8 in. (1300 x 719 x 732 mm )                            |
| Exterior Dimensions (H x D x W) | 78 x 38.5 x 34 in. (1981 x 978 x 864 mm )                                |
| Shipping Dimensions             | 83.12 x 42.75 x 41.88 in. (2111 x 1086 x 1064 mm )                       |
| Shipping Weight / Net Weight    | 668 lbs. (304 kg) / 574 lbs. (260 kg)                                    |
| Insulation                      | Vacuum Insulation Panels with High-Density Water-Blown Polyurethane Foam |
| Door Seal                       | Silicone-Based Gasket Seal with Electrical Door Perimeter Heater         |
| Shelves                         | 4 Stainless Steel<br>Adjustable Shelves in 1" (25mm) Increments          |
| Shelf Capacity                  | Max. Capacity per Shelf: 205 lbs. (91.7 kg)                              |
| Interior / Exterior Material    | Painted Steel (Stainless Steel Option) / Painted Steel                   |
| All-Direction Casters           | Standard with Locks  |
| Other Options                   | LN2 or CO2 Backup System, Chart Recorder                                 |

**Electrical System Configuration**

|                               |   |
|-------------------------------|---|
| Controller Level              | Top   |
| Power Switch                  | (Rear) Main Circuit Breaker   |
| Controller Type               | HIC Interface: 7-segment Display with Capacitive Touch Screen Buttons |
| Setpoint Security             | Yes   |
| Compressor Safe Guard         | High Temp Cutout Switch, Current, Logic protection                    |
| Control Sensor                | Single RTD (1000 ohm Platinum RTD)                                    |
| Connectivity / Remote Outputs | RS485/4-20mA output/Dry Contacts                                      |
| Thermo Fisher Cloud           | InstrumentConnect™ Remote Monitoring (compatible)                     |
| Adjustable Warm/Cold Alarms   | Fully Adjustable  |

**Refrigeration Configuration**

|                       |   |
|-----------------------|---|
| Refrigeration System  | Single Stage HC Refrigeration System          |
| Compressor/Number     | Industrial Rated, Hermetically Sealed / 1     |
| Compressor Capacity*  | 559 W   |
| Condenser Type        | Enhanced Tube and Fin with Forced-Air Cooling |
| Expansion Device      | Capillary Tube                                |
| Evaporator Type       | Enhanced Cold Wall Design                     |
| Defrost Method        | Manual Defrost                                |
| Refrigerant           | R290  |
| Environmental Effects | GWP: 3 (R290)<br>ODP: 0 (R290)                |
| Flammable             | Yes   |

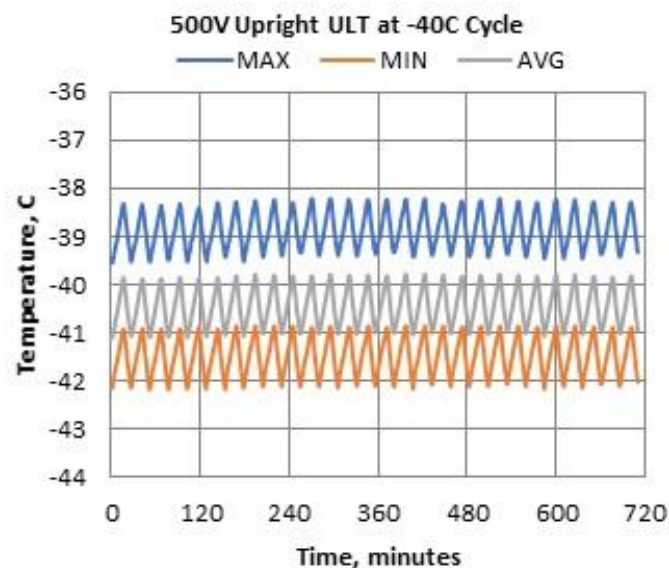
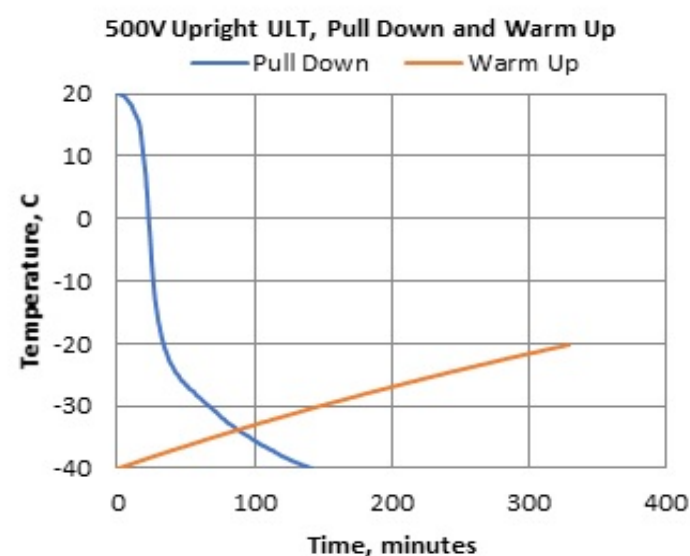

- 1) Performance is nominal and individual units may vary.
- 2) Freezer performance will differ due to product amount, product size and operating conditions.
- 3) Continuous product enhancements may, without notice, result in amendments or omissions to this specification. Thermo Scientific cannot accept responsibility for damage, injury, loss or expenses resulting from misapplication of the information herein.

\* Manufacturer measured compressor capacity taken at standard -35°C/45°C (Evap/Cond) condition.

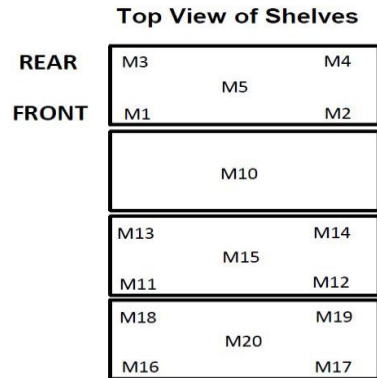

**Cabinet Average:** -40.4 C  
**Probe Average:** -42.0 C  
**Peak Variation:** +1.8 C / -2.2 C

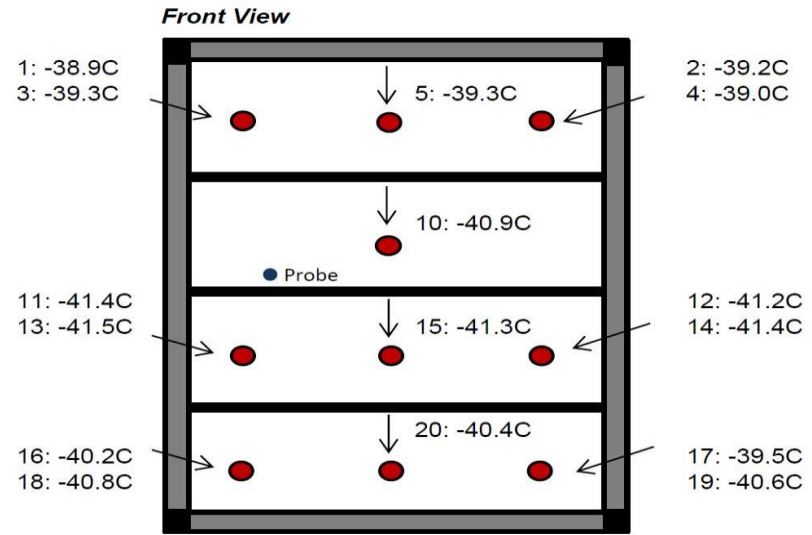

19715-H-22

|     | M1    | M2    | M3    | M4    | M5    | M10   | M11   | M12   | M13   |
|-----|-------|-------|-------|-------|-------|-------|-------|-------|-------|
| Avg | -38.9 | -39.2 | -39.3 | -39   | -39.3 | -40.9 | -41.4 | -41.2 | -41.5 |
| Max | -38.2 | -38.6 | -38.6 | -38.2 | -38.6 | -40.1 | -40.9 | -40.6 | -40.7 |
| Min | -39.6 | -39.9 | -40   | -39.9 | -40   | -41.6 | -42   | -41.8 | -42.2 |

|     | M14   | M15   | M16   | M17   | M18   | M19   | M20   |
|-----|-------|-------|-------|-------|-------|-------|-------|
| Avg | -41.4 | -41.3 | -40.2 | -39.5 | -40.8 | -40.6 | -40.4 |
| Max | -40.7 | -40.7 | -39.7 | -38.9 | -40   | -39.7 | -39.8 |
| Min | -42.2 | -41.9 | -40.7 | -40.3 | -41.6 | -41.4 | -41   |

**DOOR OPEN @ 180°**

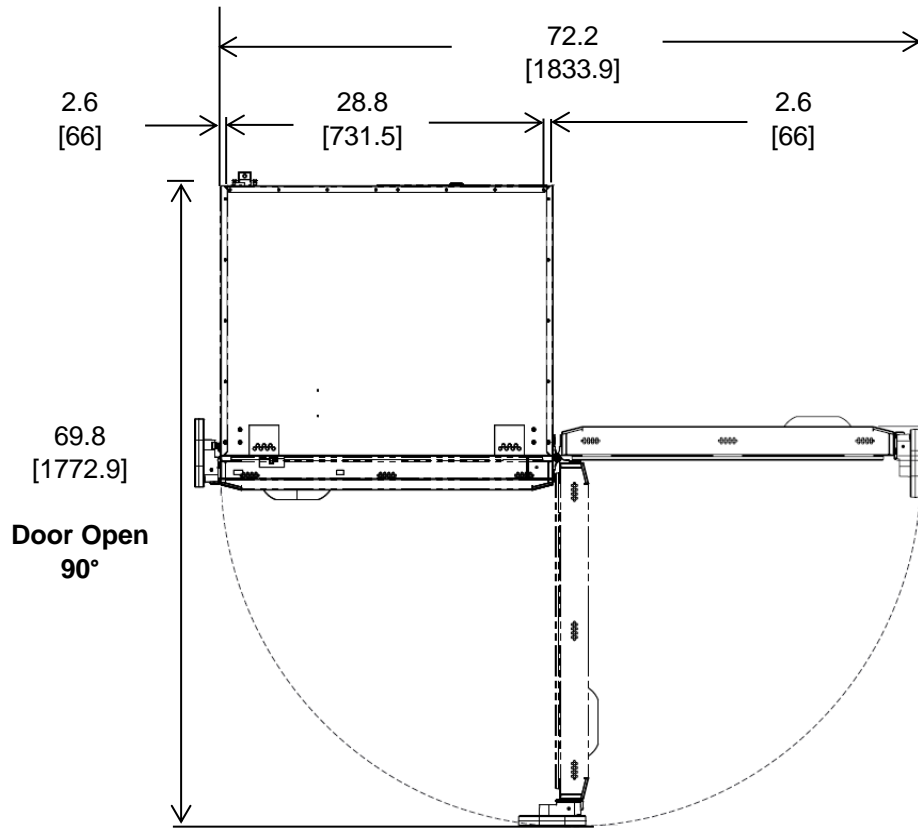

**Door Open 90°**

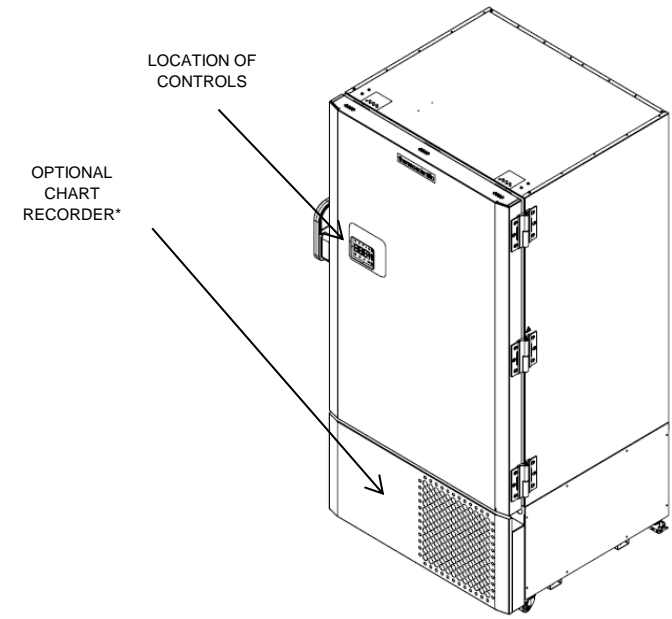
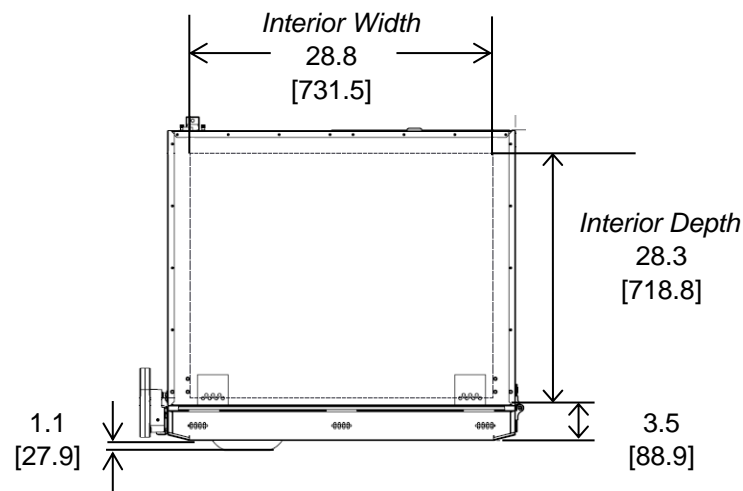

\*Chart recorders are stand alone on 300/400 models  
\*Backup systems are stand alone on 300 models.

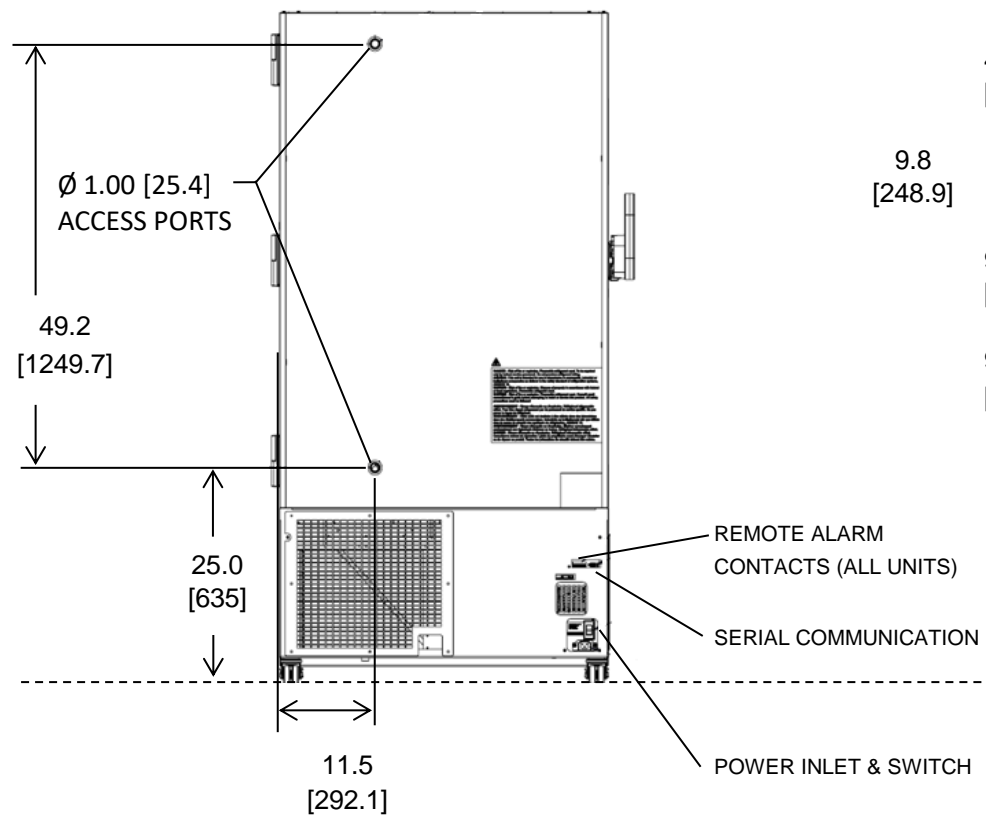

**BACK**

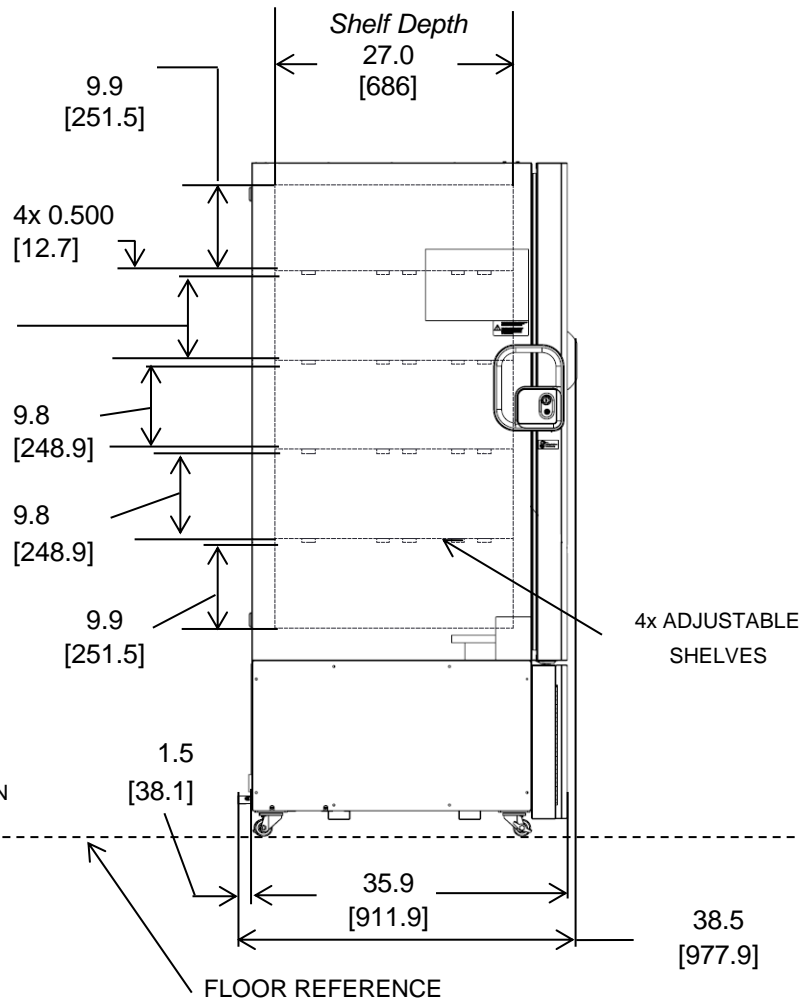

4x ADJUSTABLE SHELVES

FLOOR REFERENCE

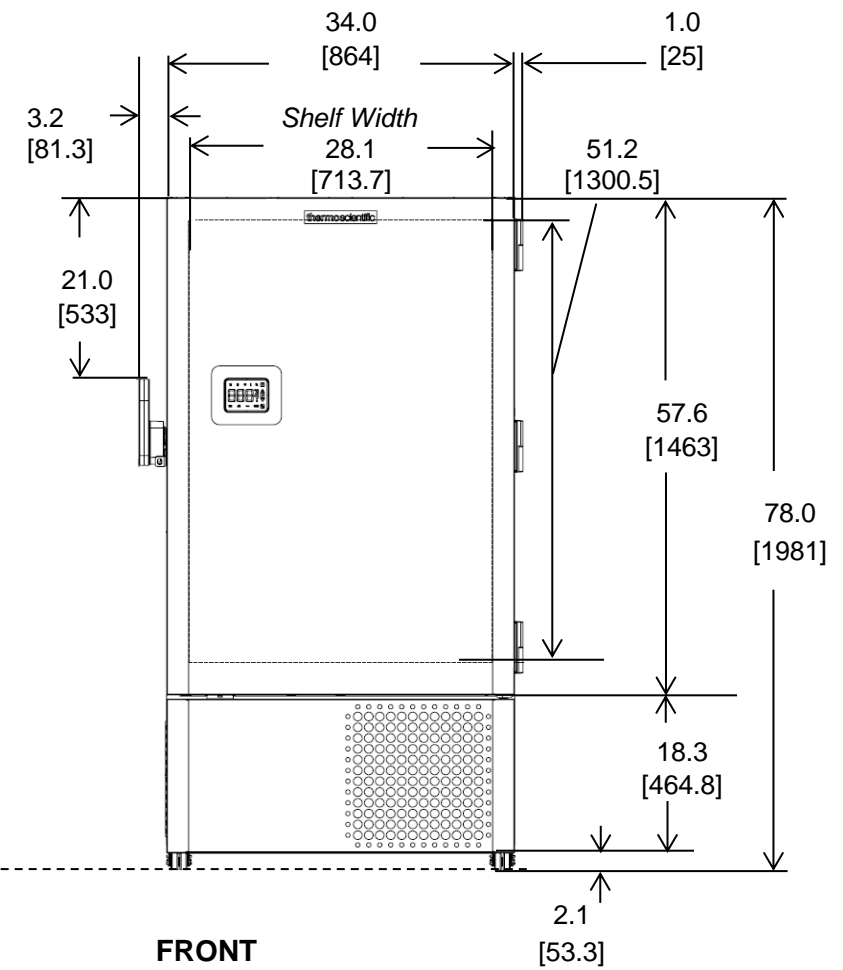

**FRONT**

**NOTE: DUAL DIMENSION IS INCH OVER METRIC**

DO NOT USE FOR ENGINEERING PURPOSES. SUBJECT TO CHANGE WITHOUT NOTICE.



**24.1 cuft Upright Freezer**  
5 Inner Doors  
Single Outer Door  
Top Mount Controls