



Technical Data Sheet
Revco Ultra-Low Temperature Chest Freezer
 MODEL RELEASE - 21
 Thermo Fisher Scientific, Asheville, North Carolina

Specifications	Model Number
	ULT1750-10-V
Application, Rating and Electrical Data	
Application	Storage of General (non-flammable) Laboratory Materials
Storage Volume	481.4 Liters/17 Cubic Feet
Temperature Rating	-10°C to -40°C
Electrical Power	230V 50 Hz, 1 Phase
Instrument Rated Current	6.5 AMP
Building Supply Rating	8.0A dedicated grounded circuit. Protected by circuit breaker rated for inductive loads
Power Plug/Power Cord Length	Country Dependant plug / IEC Cords, 3.048 Meters (10 Feet)
Agency Listings	CE, FDA
Indoor/Outdoor Usage	Indoor Use Only
Application Environment	Non-Corrosive, Non-Flammable, Non-Explosive, Good Air Ventilation, 15° C - 32° C (59° F - 90° F)
Refrigeration Configuration	
Refrigeration System	Industrial-Rated one-stage System
Compressor / Number	Hermetic Compressor for Low Temperature Application / 1
Compressor Capacity*	730 W
Condenser Type/Number	Enhanced Finned-Tube and Forced-Air Cooled / 1
Expansion Device	Capillary Tube
Evaporator Type	Cold Wall With Enhanced Heat Transfer Treatment
Defrost Method	Manual Defrost
Refrigerant Charge/Flammability	R404A / Non-Flammable
Controller/Electrical System Configuration and Features	
Controller Level	Top
Power Switch	On-Off with Circuit Breaker
Controller Type	Microprocess Control
Setpoint Security	YES
Compressor Safe Guard	High Pressure Cutout Switch/High Temp Cutout Switch/Current protection/Logic protection
Control Sensor	Single RTD (1000 ohm Platinum RTD)
Remote Alarm Terminals	RS485, 4-20mA, Dry Contacts
Adjustable Warm/Cold Alarms	Fully Adjustable
Auto-Voltage Safeguard	Buck/Boost System
Dimensions and Construction	
Interior Dimensions (H x D x W)	706 H x 470 D x 1473 W mm (27.8 H x 18.5 D x 58 W in.)
Exterior Dimensions (H x D x W)	1031 H x 829 D x 2225 W mm (40.6 H x 32.7 D x 87.6 W in.)
Shipping Dimensions	1168 H x 973 D x 2677 W mm (46 H x 38.3 D x 105.4 W in)
Insulation	High Density Polyurethane Foam, R-30 (ft ² ·°F·hr/Btu)
Door Seal	Silicone-Based High Performance Seal Gasket
Shelves / Capacity	N/A
All-Direction Casters	Standard with Locks
Unit Weight	Approximately 324 kg / 714 lbs.
Other Options	Electronic Recorder and CO2 or LN2 Back-Up System or Datalogger

Typical Performance Characteristics in 25° C Ambient

17 ft³ Chest ULT, Pull Down and Warm Up at 25 C

17 ft³ Chest ULT, -40C Cycle at 25 C Ambient

Test Unit Series or MSO Number:	18828-CB-AD
Avg Cabinet Temp at -40 C Cycle (C):	-35.7
Peak Variation from Setpoint (C):	+ 6.5 / + 2.4
Average Uniformity (C):	1.3
Average Stability (C):	2.6
Duty Cycle at -40C Setpoint (%):	59.2%
Cycle (on/off) rate at -40C (min):	17 / 12
Avg. energy consumption (kW-hr/day):	8.2
Avg. heat rejection rate (Btu/hr):	1168
Overall Pulldown Time (to -40C) (mins):	153
Warmup Time (-40 to -20 C) (minutes):	203

- Performance is nominal and individual units may vary.
- Freezer performance will differ due to product amount, product size and operating conditions.
- Continuous product enhancements may, without notice, result in amendments or omissions to this specification. Thermo Scientific cannot accept responsibility for damage, injury, loss or expenses resulting from misapplication of the information herein.

* Manufacturer measured compressor capacity taken at standard -23°C/49°C (Evap/Cond) condition.

© 2012 Thermo Scientific Inc. All trademarks are the property of Thermo Scientific Inc. and its subsidiaries. Specifications, terms and pricing are subject to change. Not all products are available in all countries. Please consult your local sales representative for details.

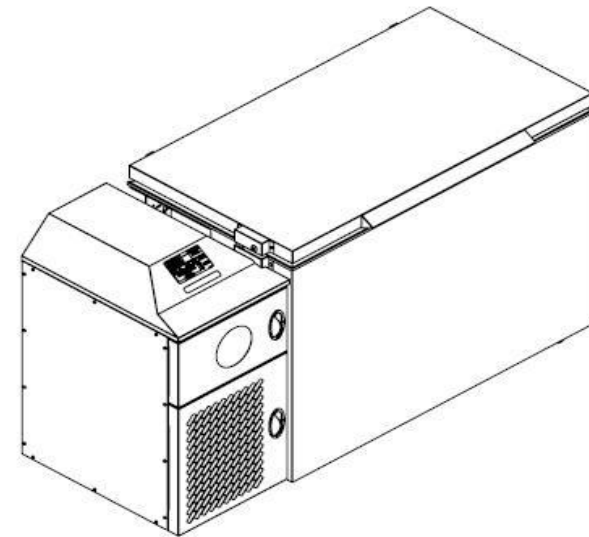
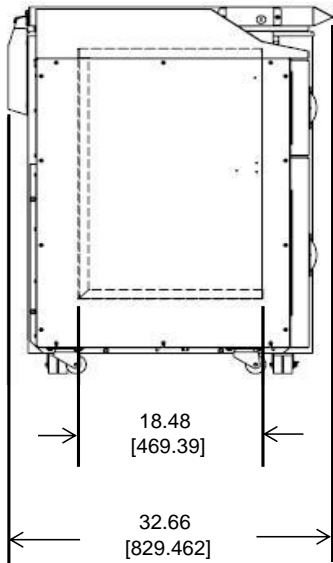

OPTIONAL BACKUP SYSTEM CONNECTOR

POWER LABEL & SWITCH

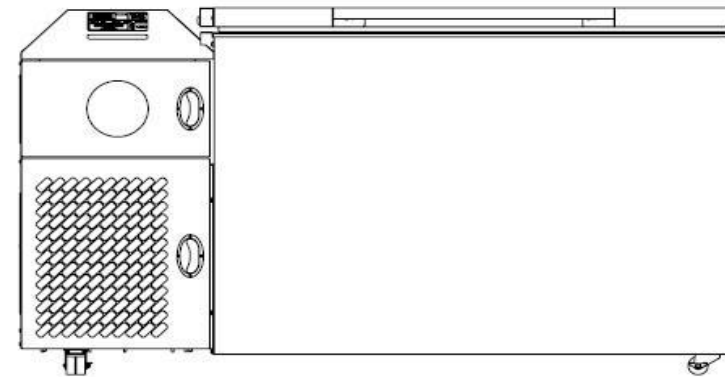
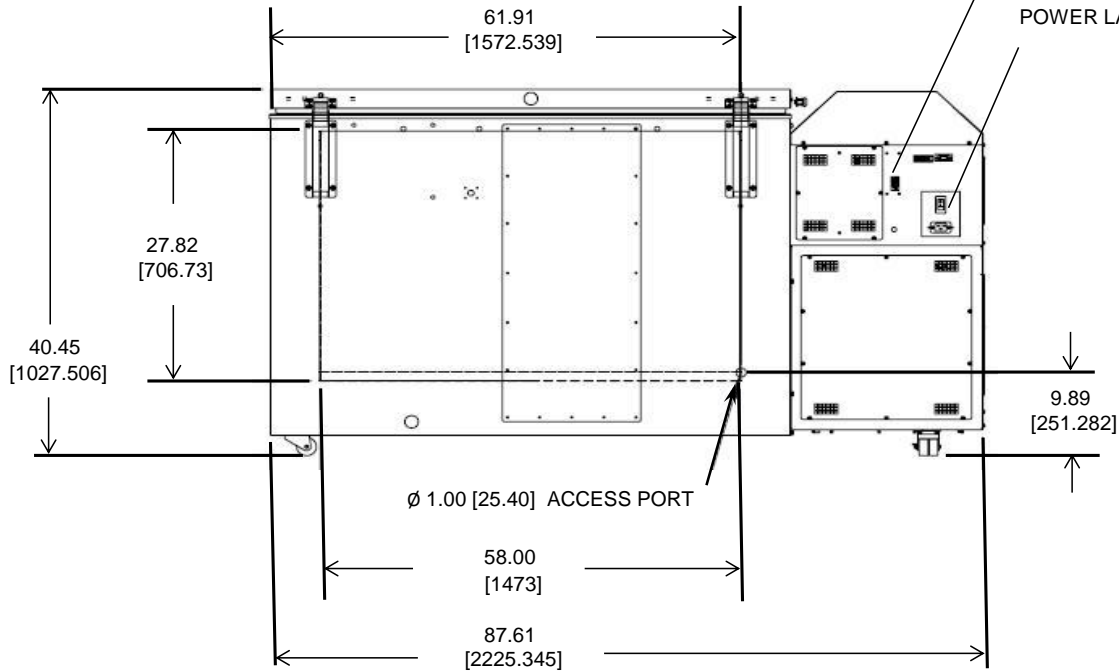

Thermo
SCIENTIFIC

17 cuft Chest Freezer

NOTE: DUAL DIMENSION IS INCH OVER METRIC
DO NOT USE FOR ENGINEERING PURPOSES. SUBJECT TO CHANGE WITHOUT NOTICE.