



Technical Data Sheet

Forma Ultra-Low Temperature Upright DD Freezer

MODEL RELEASE - 21

Thermo Fisher Scientific, Asheville, North Carolina

| Specifications | Model Number |
|---|--|
| | 994 |
| Application, Rating and Electrical Data | |
| Application | Storage of General (non-flammable) Laboratory Materials |
| Storage Volume | 489.9 Liters / 17.3 Cubic Feet |
| Temperature Rating | -50°C to -86°C |
| Electrical Power | 230V 50 Hz, 1 Phase |
| Instrument Rated Current | 12.0 AMP |
| Building Supply Rating | 15.0A dedicated grounded circuit. Protected by circuit breaker rated for inductive loads |
| Power Plug/Power Cord Length | Country Dependant plug / IEC Cords, 3.048 Meters (10 Feet) |
| Agency Listings | CE, FDA |
| Indoor/Outdoor Usage | Indoor Use Only |
| Application Environment | Non-Corrosive, Non-Flammable, Non-Explosive, Good Air Ventilation, 15° C - 32° C (59° F - 90° F) |
| Refrigeration Configuration | |
| Refrigeration System | Industrial-Rated Two Stage Cascade System |
| Compressor / Number | Hermetic Compressor for Low Temperature Application / 2 |
| Compressor Capacity* | 980 W |
| Condenser Type/Number | Enhanced Finned-Tube and Forced-Air Cooled / 1 |
| Expansion Device | Capillary Tube |
| Evaporator Type | Cold Wall With Enhanced Heat Transfer Treatment |
| Defrost Method | Manual Defrost |
| Refrigerant Charge/Flammability | R404A in 1st Stage / R508B+R290 Mix in 2nd Stage / Non-Flammable |
| Controller/Electrical System Configuration and Features | |
| Controller Level | Top |
| Power Switch | On-Off with Circuit Breaker |
| Controller Type | Microprocess Control |
| Setpoint Security | NO |
| Compressor Safe Guard | High Pressure Cutout Switch/High Temp Cutout Switch/Current protection/Logic protection |
| Control Sensor | Single RTD (1000 ohm Platinum RTD) |
| Remote Alarm Terminals | RS485, 4-20mA, Dry Contacts |
| Adjustable Warm/Cold Alarms | Fully Adjustable |
| Auto-Voltage Safeguard | Buck/Boost System |
| Dimensions and Construction | |
| Interior Dimensions (H x D x W) | 1308 H x 645 D x 586 W mm (51.5 H x 25.4 D x 23.1 W in.) |
| Exterior Dimensions (H x D x W) | 1978 H x 988 D x 912 W mm (77.9 H x 38.9 D x 35.9 W in.) |
| Shipping Dimensions | 2096 H x 1156 D x 1062 W mm (82.5 H x 45.5 D x 41.8 W in) |
| Insulation | High Density Polyurethane Foam, R-30 (ft ² ·°F·hr/Btu) |
| Door Seal | Silicone-Based High Performance Seal Gasket |
| Shelves / Capacity | 3 Stainless Steel Shelves Adjustable In 25 mm (1 in) Increment; Maximum Capacity/Shelf: 45.4 kg (100 Lbs.) |
| All-Direction Casters | Standard with Locks |
| Unit Weight | Approximately 338 kg / 745 lbs. |
| Other Options | Electronic Recorder and CO2 or LN2 Back-Up System or Datalogger |

Typical Performance Characteristics in 20 ° C Ambient

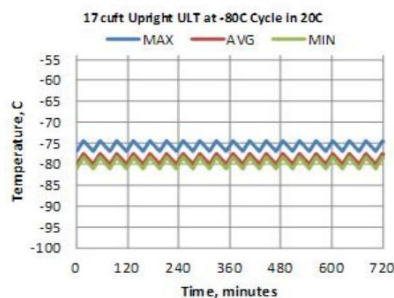
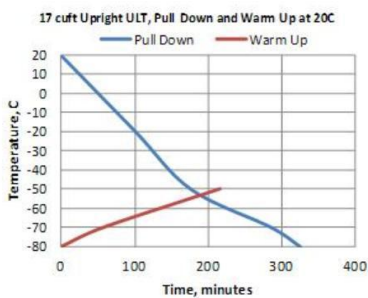

| | |
|--|-------------|
| Test Unit Series Number or MSO Number: | Extrap Data |
| Cabinet Load: | Unloaded |
| Average Cabinet Temp at -80C Cycle (C): | -78.8 |
| Peak Variation from Setpoint (C): | +5.6/ -1 |
| Uniformity (C): | 6.2 |
| Stability (C): | 1.7 |
| 1-min Door Opening Recovery to -75C (min): | 30 |
| Duty Cycle at -80C (%): | 62 |
| Cycle (on/off) rate at -80C (min): | 23 / 16 |
| Energy Consumption (kw-hr/day): | 16.0 |
| Heat Rejection Rate (btu/hr): | 2279 |
| Pull Down Time (to -80C) (min): | 326 |
| Warm Up Time (-80C to -50C) (min): | 216 |

- 1) Performance is nominal and individual units may vary.
- 2) Freezer performance will differ due to product amount, product size and operating conditions.
- 3) Continuous product enhancements may, without notice, result in amendments or omissions to this specification. Thermo Scientific cannot accept responsibility for damage, injury, loss or expenses resulting from misapplication of the information herein.

* Manufacturer measured compressor capacity taken at standard -23°C/49°C (Evap/Cond) condition.

© 2012 Thermo Scientific Inc. All trademarks are the property of Thermo Scientific Inc. and its subsidiaries. Specifications, terms and pricing are subject to change. Not all products are available in all countries. Please consult your local sales representative for details.

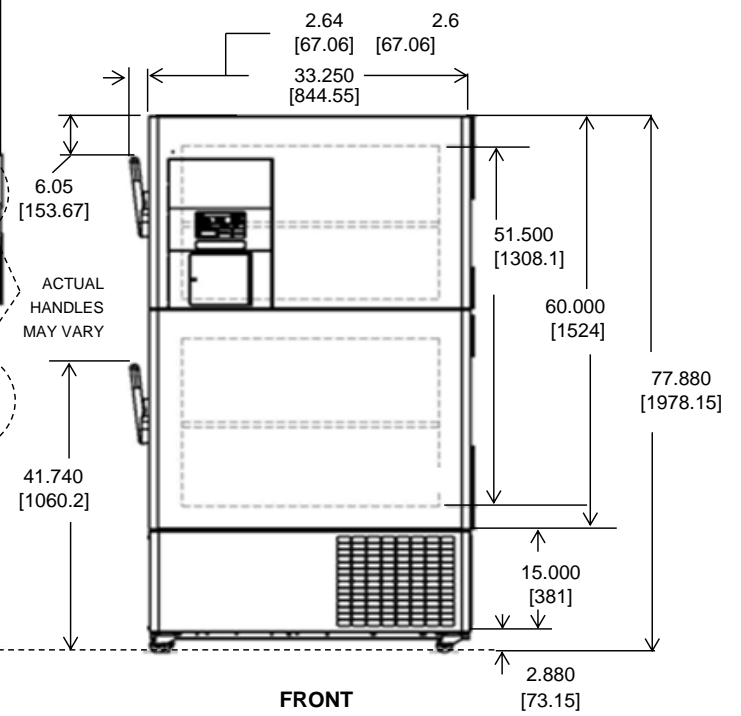
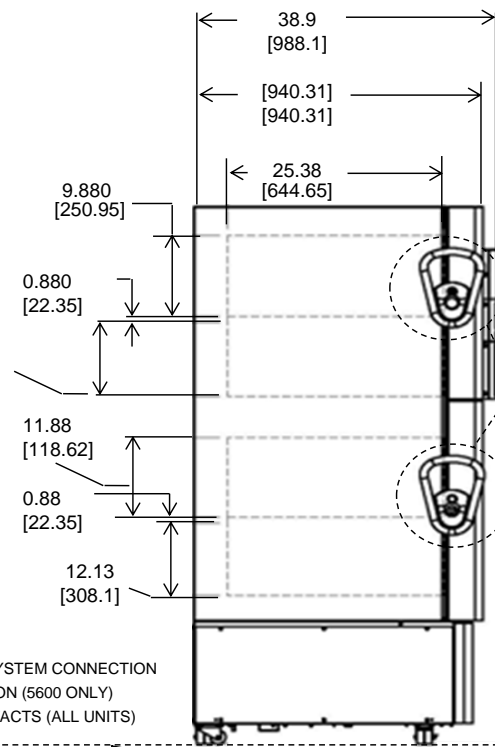
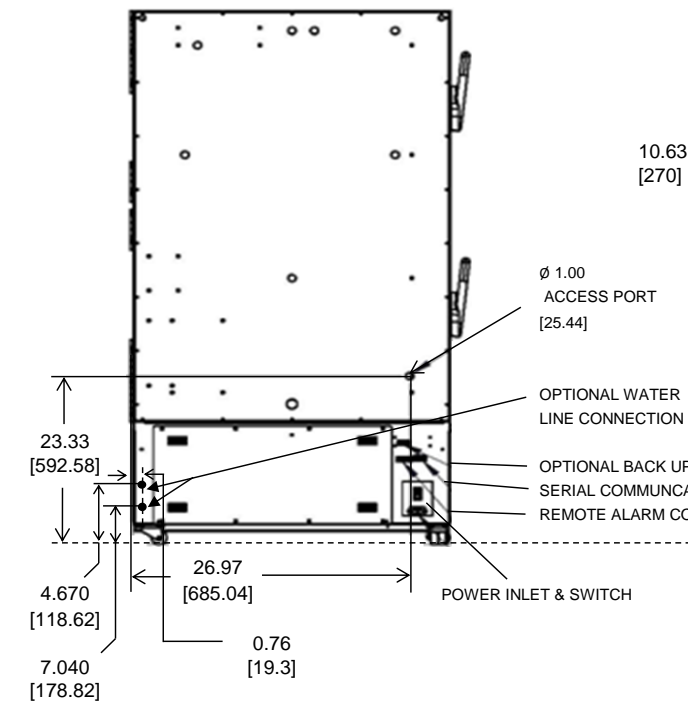
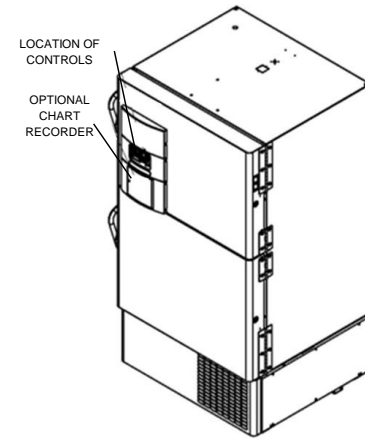
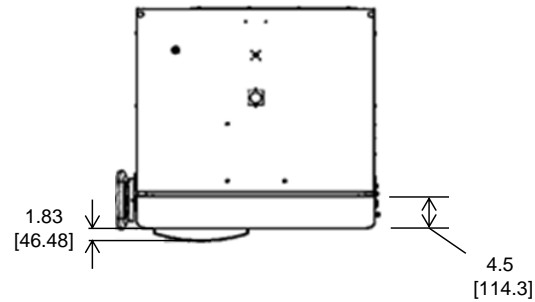
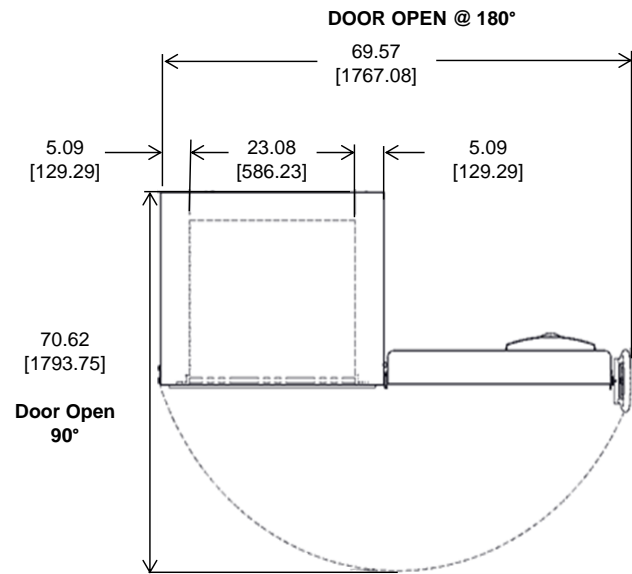

NOTE: DUAL DIMENSION IS INCH OVER METRIC

DO NOT USE FOR ENGINEERING PURPOSES. SUBJECT TO CHANGE WITHOUT NOTICE.

Thermo
SCIENTIFIC

17 cuft Upright DD Freezer
4 Inner Doors
Two Outer Door s
Top Mount Controls