



Ultra Low Temperature Freezers

TSX Series

Installation and Operation

333480H01 • Revision B • 01/23/2024

IMPORTANT Read this instruction manual. Failure to follow the instructions in this manual can result in damage to the unit, injury to operating personnel, and poor equipment performance.

CAUTION All internal adjustments and maintenance must be performed by qualified service personnel.

Material in this manual is for informational purposes only. The contents and the product it describes are subject to change without notice. Thermo Fisher Scientific makes no representations or warranties with respect to this manual. In no event shall Thermo Fisher Scientific be held liable for any damages, direct or incidental, arising from or related to the use of this manual.

© 2024 Thermo Fisher Scientific Inc. All rights reserved.

Contents

| | |
|---|----|
| Intended Use | 1 |
| Intended Use - General Purpose | 1 |
| Intended Use - Medical Device | 1 |
| EPA ENERGY STAR..... | 1 |
| Safety Precautions | 3 |
| Unpacking | 5 |
| Packing List | 6 |
| General Recommendations..... | 7 |
| Temperature Monitoring | 7 |
| General Usage | 7 |
| Initial Loading | 7 |
| Breaker Switch and Battery Door Opening / Closing | 7 |
| Operating Standards..... | 8 |
| Electrical Specifications | 8 |
| Installation..... | 9 |
| Location | 9 |
| Protective Conductor Current..... | 9 |
| Wiring..... | 9 |
| Attach Power Cord | 9 |
| Leveling..... | 10 |
| Backup System (Optional) | 10 |
| Super Insulated Cabinet Construction | 10 |
| Door Operation | 10 |
| Pressure Equalization Port..... | 11 |
| Installing the Remote Warning Connector..... | 11 |

| | |
|--|----|
| Start Up..... | 12 |
| Initial Start Up..... | 12 |
| Operation..... | 15 |
| Operation Overview..... | 15 |
| Home Screen..... | 15 |
| Settings..... | 15 |
| Event Log..... | 20 |
| Warnings..... | 20 |
| Users..... | 20 |
| Reports..... | 22 |
| Power Off and Standby Mode..... | 23 |
| Health Status and Warning Management..... | 25 |
| Health Status Overview..... | 25 |
| Notifications / Cautions..... | 25 |
| Warning / Cautions..... | 26 |
| Backup System (Optional)..... | 27 |
| CO2 and LN2 Precautions..... | 27 |
| Installation..... | 27 |
| Start Up..... | 28 |
| Operation..... | 28 |
| Chart Recorders (Freestanding)..... | 29 |
| Undercarriage Lighting (Optional)..... | 30 |
| Modification of Undercarriage Lights Settings..... | 30 |
| Disconnecting the Undercarriage Light System..... | 31 |
| Maintenance and Troubleshooting..... | 32 |
| Cleaning the Exterior..... | 32 |
| Cleaning the Condenser..... | 32 |
| Cleaning the Condenser Filter..... | 32 |

| | |
|---|----|
| Gasket Maintenance | 32 |
| Defrosting the Freezer | 32 |
| Battery Maintenance | 33 |
| Maintenance Schedule | 33 |
| Troubleshooting Guide..... | 34 |
| Warranty | 38 |
| Warranty (International) | 39 |
| Appendix A: Warning / Caution Summary | 40 |
| Appendix B: Event Log Detail..... | 48 |
| Appendix C: City Time Zone | 54 |
| Appendix D: Modbus ASCII (Read Only) Parameter Table | 61 |
| WEEE Compliance..... | 69 |
| IF YOU NEED ASSISTANCE: | 70 |

Intended Use

Intended Use - General Purpose

The General Purpose Models described below:

The Ultra Low Temperature (ULT) Freezers TSX Series (Model/s with 'F', for example TSX40086FA) are intended for long term storage and preservation of samples or inventory at temperatures between -40 °C to -86 °C. The ULT Freezers are intended to be used by trained personnel in a professional environment. It is the customer's responsibility to ensure that the performance of the product is suitable for customers' specific uses or applications.

| Model Number | Voltage | Capacity | | Energy Star Model (*)  |
|--------------|------------------|-----------------|------------|--|
| | | cu. ft (liters) | 2" cyrobox | |
| TSX40086FA | 100-230V 50/60Hz | 19.31 (549) | 400 | Yes, 115V 60Hz |
| TSX50086FA | | 24.09 (682) | 500 | |
| TSX60086FA | | 28.79 (816) | 600 | |
| TSX70086FA | | 33.56 (949) | 700 | |

Intended Use - Medical Device

The Medical Device Model described below:

The Ultra Low Temperature (ULT) Freezers TSX Series (Model/s with 'L', for example TSX40086LA) are intended for long term storage and preservation of blood and blood products at temperatures between -40 °C to -86 °C. The ULT Freezers are intended to be used by trained personnel in a professional laboratory environment.

| Model Number | Voltage | Capacity | | Energy Star Model (*)  | Medical Device |
|--------------|------------------|-----------------|------------|--|----------------|
| | | cu. ft (liters) | 2" cyrobox | | |
| TSX40086LA | 100-230V 50/60Hz | 19.31 (549) | 400 | Yes, 115V 60Hz | Class II |
| TSX50086LA | | 24.09 (682) | 500 | | Class II |
| TSX60086LA | | 28.79 (816) | 600 | | Class II |
| TSX70086LA | | 33.56 (949) | 700 | | Class II |

EPA ENERGY STAR

Lab Grade Refrigerators and Freezers:

This product family has been voluntarily evaluated, and found compliant, by an EPA approved certification body to the EPA ENERGY STAR Laboratory Grade Refrigerators and Freezers Specification 1.1. This compliance is verified at $24.0\text{ }^{\circ}\text{C} \pm 1.0\text{ }^{\circ}\text{C}$ ($75.2\text{ }^{\circ}\text{F} \pm 1.8\text{ }^{\circ}\text{F}$), installed as described in this user manual, and in the default condition and settings of the product when shipped. Details can be found in the product Technical Specification Sheet or online at energystar.gov.

Safety Precautions

In this manual, the following symbols and conventions are used:



This symbol used alone indicates important operating instructions which reduce the risk of injury or poor performance of the unit.



CAUTION: This symbol indicates a potentially hazardous situation which if not avoided could result in minor to moderate injury or damage to the equipment.



The snowflake symbol indicates extreme low temperatures and high risk of frostbite. Do not touch bare metal or samples with unprotected body parts. ISO 7010 #W010.



This symbol indicates a need to use gloves during the indicated procedures. If performing decontamination procedures, use chemically resistant gloves. Use insulated gloves for handling samples and when using liquid nitrogen.



Before installing, using, or maintaining this product, please be sure to read this manual and product warning labels carefully. Failure to follow these instructions may cause this product to malfunction, which could result in injury or damage.



Use this product only in the way described in the product literature and in this manual. Before using it, verify that this product is suitable for its intended use. If this equipment is used in a manner not specified by the manufacturer, the protection provided by the equipment may be impaired.



Do not modify system components, especially the controller. Use OEM exact replacement equipment or parts. Before use, confirm that the product has not been altered in any way.



CAUTION: Your unit must be properly grounded in conformity with national and local electrical codes. Never connect the unit to overloaded power sources.



CAUTION: Disconnect the unit from all power sources before cleaning, troubleshooting, or performing other maintenance on the product or its controls.



CAUTION: “Risk of fire”. This unit is charged with hydrocarbon refrigerants.



WARNING: This symbol indicates potentially hazardous situations which, if not avoided, could result in serious injury or death.



WARNING: This symbol indicates situations where dangerous voltages exist and potential for electrical shock is present.



This symbol indicates possible pinch points which may cause personal injury.



Hydrocarbon Refrigerant Service:

Note: According to U.S. Code of Federal Regulation 40 Part 82, this refrigerator employs the natural hydrocarbon refrigerants. Because of the nature of hydrocarbon refrigerants, for mechanical repair, such as recharge or compressor replacement, should only be carried out by a certified refrigeration technician. The safety of this equipment was evaluated by an accredited 3rd party laboratory under Product Standard UL471, section SB – “natural refrigerant” / UL 61010-2-11 - Particular Requirements for Refrigerating Equipment.

EMC (where applicable)

Korean KC Registration



사용자 안내문 이 기기는 업무용 환경에서 사용할 목적으로 적합성평가를 받은 기기로서 가정용 환경에서 사용하는 경우 전파간섭의 우려가 있습니다.

Warning Statement: EMC Registration is done on this equipment for business use only. It may cause interference when the product would be used in home. This warning statement applies a product for business use.

The use of accessories, transducers, and cables other than those specified, with the exception of transducers and cables sold by the manufacturer of the equipment or system as replacement parts for internal components, may result in increased emissions or decreased immunity.

Canadian ISED IC Notice

This ISM digital apparatus complies with Canadian ICES-001, Class A. Cet appareil ISM est conforme à la norme NMB-001 du Canada, Classe A.

Contains Transmitter module IC: 5718A-METSR.

The term "IC" before the radio certification number only signifies that Industry Canada technical specifications were met. Operation is subject to the following two conditions: (1) this device may not cause interference, and (2) this device must accept any interference, including interference that may cause undesired operation of the device.

For products available in the USA and Canadian markets, only channels 1-11 are available. User cannot select other channels.

FCC (where applicable)



This device complies with Part 15 Subpart B of the FCC Rules. Operation is subject to the following two conditions: (1) this device may not cause harmful interference, and (2) this device must accept any interference received, including interference that may cause undesired operation. Any changes or modifications not expressly approved by the manufacturer could void the user's authority to operate the equipment.

Note: This equipment has been tested and found to comply with the limits for a Class A digital device, pursuant to part 15 of the FCC Rules. These limits are designed to provide reasonable protection against harmful interference when the equipment is operated in a commercial environment. This equipment generates, uses, and can radiate radio frequency energy and, if not installed and used in accordance with the instruction manual, may cause harmful interference to radio communications. Operation of this equipment in a residential area is likely to cause harmful interference in which case the user will be required to correct the interference at his own expense. FCC ID: NNHMETSRS.

Fluorinated Gas Refrigerant Service

Compliant with Regulation (EU) No 517/2014 of the European Parliament and of the Council on fluorinated greenhouse gases, this product contains fluorinated greenhouse gases in a hermetically sealed system. In conformity with Article 14 of Regulation (EU) No 517/2014 of the European Parliament and of the Council, a declaration of conformity for F-Gas has been supplied with this unit. Please refer to that document for details regarding our compliance to this regulation.

Material Content and Evaluation of Chemicals

REACH - Europe

Thermo Fisher Scientific is committed to meeting all compliance obligations to evaluate, communicate, and register any Substances of Very High Concern (SVHC), and finding alternates where appropriate.

RoHS - Europe

Thermo Fisher Scientific is determined to reduce the impact we have on the environment, and so can declare that this product complies with the European Parliament's RoHS2 (Restriction of Hazardous Substances) Directive 2011/65/EU, and 2015/863 Annex II (RoHS2 Amendment) with respect to the limitation of the following substances:

Lead (0.1%), Mercury (0.1%), Cadmium (0.01%), Hexavalent chromium (0.1 %), Polybrominated biphenyls (PBB) (0.1%), Polybrominated diphenyl ethers (PBDE) (0.1%)

Bis(2-ethylhexyl) phthalate (DEHP) (0.1 %), Butyl benzyl phthalate (BBP) (0.1%), Dibutyl phthalate (DBP) (0.1%), Diisobutyl phthalate (DIBP) (0.1%).

Our compliance is witnessed by written declaration from our suppliers and/or component testing. This confirms that any potential trace contamination levels of the substances listed above are below the maximum level set by the latest regulations or follow established exemptions of the regulation due to their application.

RoHS - China

This product complies with the requirements of the legislative act Administration on the Control of Pollution Caused by Electronic Information Products (ACPEIP). A label of conformance, such as one of the following, may be found on the product:

A declaration may be obtained from the manufacturer with greater detail of this conformance.

Proposition 65 – California

This product complies with California Proposition 65.

Unpacking

At delivery, examine the exterior for physical damage while the carrier's representative is present. If exterior damage is present, carefully unpack and inspect the unit and all accessories for damage.

If there is no exterior damage, unpack and inspect the equipment within five days of delivery. If you find any damage, keep the packing materials, and immediately report the damage to the carrier. Do not return goods to the manufacturer without written authorization. When submitting a claim for shipping damage, request that the carrier inspect the shipping container and equipment.

Upon receiving the unit, properly dispose of any packaging material used to secure the unit during the shipping process. Please refer to local recycling codes and dispose of any materials accordingly. For information on waste disposal sites, please refer to your local waste provider.

Packing List

This manual can be found at
www.thermofisher.com/usermanuals

Inside the freezer cabinet is a bag containing:

- A handle lock key
- A remote warning contact connector
- Posts for rear spacing
- Certificate of Calibration
- EC Declaration of Conformance
- Test Log
- Temperature profile
- Power Cord

If you have ordered a backup system, the cabinet will also contain:

- A hose assembly
- English and metric connectors

If you have ordered the Proximity Access Card Option, the cards will be in a bag attached to the front of the freezer.

Additional accessory information may be found here:



General Recommendations

Temperature Monitoring



IMPORTANT NOTE: We recommend the use of a redundant and independent temperature monitoring system so that the freezer can be monitored continuously for performance commensurate with the value of product stored.



General Usage

This refrigeration system is designed to maintain ultra-low temperatures with safety in an ambient environment within 15 °C to 32 °C (59 °F to 90 °F), only when the freezer is used for storage.



CAUTION: This unit is not a “rapid-freeze” device. Freezing large quantities of liquid, or items with high water content, will temporarily increase the chamber temperature and will cause the compressors to operate for a prolonged time period.

Avoid opening the door for extended time periods since chamber temperature air will escape rapidly. Also, keep the inner doors closed as much as possible. When room air, which is higher in humidity, replaces chamber air, frost may develop in the chamber more rapidly.

Initial Loading

Allow the freezer to operate at the desired temperature for a minimum of 12 hours before loading.

Load the freezer one shelf at a time. When using racks (part numbers: 920090, 398329, 398322, 1950520, 1950518, 1950519, 1950522, 1950639, 920091, 398328, 1950521, 1950592, 1950523, 1950642, 1950787, 1950791, 1950642, 1950799, 1950819) or racks combined with generic storage, it is important to follow these guidelines:

- Start loading racks from the bottom shelf (cabinet floor) and work upwards.
- Avoid removing more than 2 racks from a shelf at the same time, except for upper most shelf containing racks.

The shelf load ratings are as follows:

- For generic storage, the shelf rating is 150lb.
- Including the considerations mentioned above, the shelf ratings for the rack-based storage is as follows:
 - 400 size: 165lb
 - 500 size: 205lb
 - 600 size: 245lb
 - 700 size: 285lb



CAUTION: Failure to load more than one shelf at the time, may cause excessive stress on the compressors.



WARNING: Failure to follow these ratings or procedures may damage the shelving system potentially resulting in injury.

Breaker Switch and Battery Door Opening / Closing

To open the grille door, pull the door from the top right corner as shown in the following figure.

To close the grille door, push the door against frame to hold latch in position.



Figure 1. Door Opening

Operating Standards

The freezers described in this manual are classified for use as stationary equipment in a Pollution Degree II and over voltage Category II environment.

These units are designed to operate under the following environmental conditions:

- Indoor use.
- Altitude up to 2000 m.
- Maximum relative humidity 60% for temperatures within 15 °C to 32 °C (59 °F to 90 °F).
- Main supply voltage fluctuation shall not exceed $\pm 10\%$ of the nominal voltage. For the 100V input condition this should be +10% and -8%.
- For the TSX series, the ULT should not be connected to a GFCI (Ground Fault Circuit Interrupter) protected outlet as it may be subject to nuisance tripping.

Electrical Specifications

The data plate identifies the electrical specifications and current ratings for your unit.

Table 1. TSX Series Electrical Specifications

| Model | Voltage | Frequency | Current |
|------------|-----------|-----------|-----------|
| TSX40086FA | 100-230 V | 50/60 Hz | 8.9-4.9 A |
| TSX40086LA | | | |
| TSX50086FA | | | |
| TSX50086LA | | | |
| TSX60086FA | | | |
| TSX60086LA | | | |
| TSX70086FA | | | |
| TSX70086LA | | | |

Note: Specified voltage range implies the input voltage is a standard global voltage.

Installation



WARNING: Do not exceed the electrical rating printed on the data plate located on the lower left side of the unit.



WARNING: Always connect the freezer to a dedicated (separate) circuit. Each freezer is equipped with a service cord and plug designed to connect it to a power outlet which delivers the correct voltage. Supply voltage must be within $\pm 10\%$ of the freezer rated voltage.



WARNING: Never remove or disable the grounding prong from the service cord plug. If the prong is removed, the warranty is invalidated.



WARNING: Always connect the power cord at inlet with factory installed retainer. Absence of retainer can result in severe damage to the equipment.

Location

Install the unit in a level area free from vibration with a minimum of 8 inches (20 cm) of space on the top and sides, 6 inches (15 cm) at the back. Refer to **Leveling** for further instructions on leveling cabinets. Allow enough clearance so that door can swing open at least 85°.

The rear spacing posts provided with the freezer can be used to ensure proper clearance. To install the spacing posts, screw them into the back in the rear deck area.

Avoid placing the equipment in direct sunlight or in proximity to heating diffusers, radiators, or other heat sources. Be certain to adhere to the conditions listed in the operating standards section. Refer to **Operating Standards**.

Protective Conductor Current

The maximum limit of 10 mA shall not be exceeded when tested according to Clause 5.5 (Measurement of protective conductor current) of DIN EN 50678 VDE 0701.

Table 2: Common Power Cord Specifications

| Region | Power Cord Specification |
|---------------|---|
| North America | 3-G 12 AWG, NEMA 5-20P, 20A/125V |
| North America | 3-G 12 AWG, NEMA 6-15P, 15A/250V |
| Europe | 3-G 1.5 mm ² , CEE 7/7, 16A/250V |

Wiring



CAUTION: Do not position the unit in a way that impedes access to the disconnecting device.



WARNING: Connect the equipment to the correct power source. Incorrect voltage can result in severe damage to the equipment.



WARNING: For personal safety and trouble-free operation, this unit must be properly grounded before it is used. Failure to ground the equipment may cause personal injury or damage to the equipment. Always conform to the National Electrical Code and local codes. Do not connect the unit to overloaded power lines.

Attach Power Cord

Ensure that the floor is leveled. The unit must be leveled both front to back and side to side. Insert the power cord into the power inlet module. Place the retaining bracket (P/N 195763) over the connector. Tighten retaining screws to secure. Attach Power Cord shown in **Figure 2**.

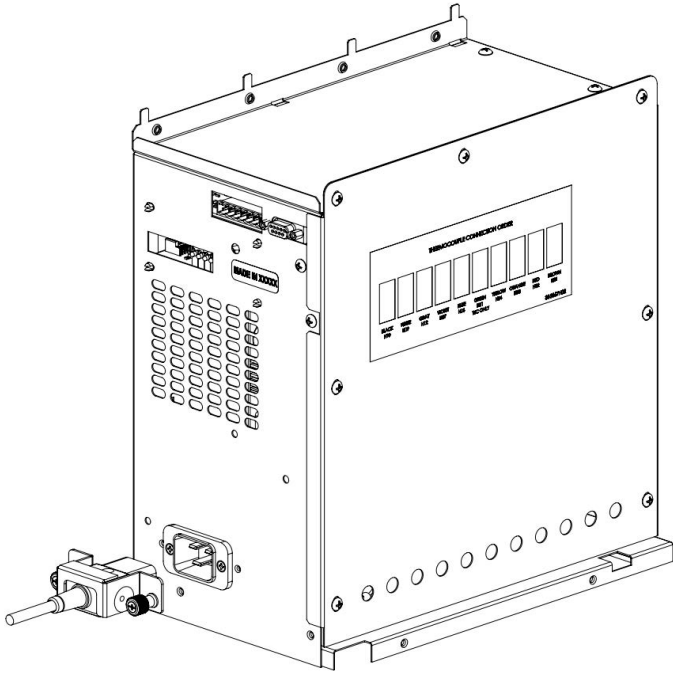

Figure 2. Attach Power Cord

Leveling

Ensure that the floor is leveled. The unit must be level both front to back and side to side.

TSX40086* models are equipped with one leveling leg on the right-hand side. These may be used to help prevent the unit from shifting during a door opening.

Ensure to lock the brakes for the units equipped with casters.

Backup System (Optional)

If you are using a CO₂ or LN₂ backup system, refer to **Backup System (Optional)** for installation and operation instructions.

Super Insulated Cabinet Construction

The cabinet walls in all the models have a vacuum insulation core encapsulated by a sealed film laminate.



CAUTION: Never drill holes in or near the cabinet walls. Drilling could damage the insulation and make the unit inoperable.

Door Operation

Upright freezer models are equipped with an advanced assembly, specifically designed for ultra-low temperature freezers.

Features include:

- One-hand operation.
- A front-accessible lock.
- Hasps for a standard padlock to provide additional security. Length of the shackle must be between 3/4 inch (1.9 cm) and 1 1/2 inch (3.8 cm).
- Durable construction for reliable operation and safe product storage.
- Door ramp alignment feature.
- Optional controlled access to the freezer with Proximity Access cards.



WARNING: When moving the freezer, always hold onto the cabinet surfaces; refrain from pulling the freezer by the latch handle.

Opening the Door

For freezers with the Proximity Access Card option:

1. Remove the padlock, if installed.
2. To open the door, swipe the card in front of the freezer beneath the LCD display.
3. Hold the latch handle and pull it towards you until it disengages from the cabinet strike.
4. Continue pulling on the latch handle to open the main door.

For freezers without the Access Card option:

1. Remove the padlock if installed.
2. Hold the latch handle and pull it towards you until it disengages from the cabinet strike.
3. Continue pulling on the latch handle to open the main door.

Opening the Door During a Power Outage

In case of a power outage the user can use a 9V battery to activate the system if the unit has a Proximity Access Card option. To access the 9V terminal, remove the USB cover and identify the battery terminals.

After identifying the terminals, open the door by holding/pressing the 9 V battery against the terminals and then swipe

a valid proximity card below the display area. Once the door is open, remove the 9V battery.

Note: The terminals are polarized, therefore orient the 9 V battery properly according to plus and minus shown behind USB cover.

Closing the Door

Note: The latch does not automatically engage upon closing the door. Users need to manually rotate the latch into the open position first.

1. Grasp the latch handle (preferably with the user's left hand) and pull it toward yourself, rotating the latch into the open position.
2. Bring the freezer door to closed position and gently push the handle away from you, to ensure that the latch fully engages with the cabinet strike.
3. Continue applying gentle pressure to the latch handle until the latch securely closes.
4. Insert the key and rotate counterclockwise to lock.
5. Replace the padlock as required.

Pressure Equalization Port

When the door of an upright ultra-low temperature freezer is opened, room temperature air enters the storage compartment. Upon closing the door, the enclosed air is rapidly cooled, causing a significant drop in pressure below atmospheric levels, creating a substantial vacuum. Re-entering the cabinet may be challenging until internal pressures return to atmospheric levels. Without a pressure equalization mechanism, it may take several hours before the door can be easily reopened.

All upright models include a port designed to provide vacuum relief after door openings. This pressure equalization port is located in the door behind the user interface panel on the front of the freezer. While the port is self-defrosting, the accumulation of excessive frost on the inner door could potentially restrict airflow. Therefore, it is recommended to regularly inspect the inner door and remove any loose frost using a stiff nylon brush.

Installing the Remote Warning Connector

The remote warning contacts are positioned behind the freezer, above and to the right of the power inlet. Once the wiring from the remote warning is installed to the connector, proceed to attach the connector to the freezer micro-board.

The pin configuration is shown in **Figure 3:**

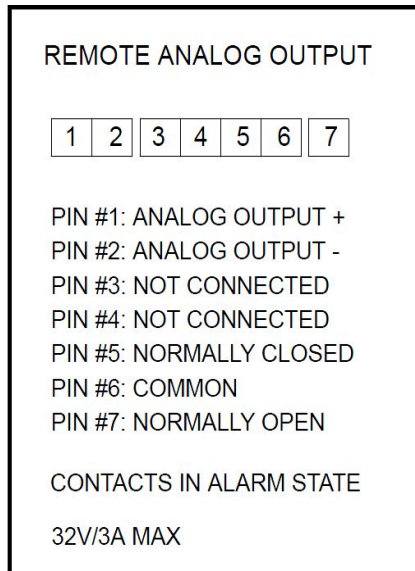

Figure 3. Remote warning Pin Configuration

The contacts of the relay will trip in the event of a warning. This includes a power failure, high temperature warning, low temperature warning and door open warning.

Start Up

Initial Start Up

To start up the freezer, complete the following steps:

1. Plug the freezer into the power outlet.
2. Turn ON the power switch, located behind the front grille door, near the upper left corner.
3. Once the freezer is powered ON, the Thermo Scientific logo is displayed on the front screen. If this is the first time the unit is being turned ON, an initial setup must be completed. Press the Start Setup button to initiate the setup.

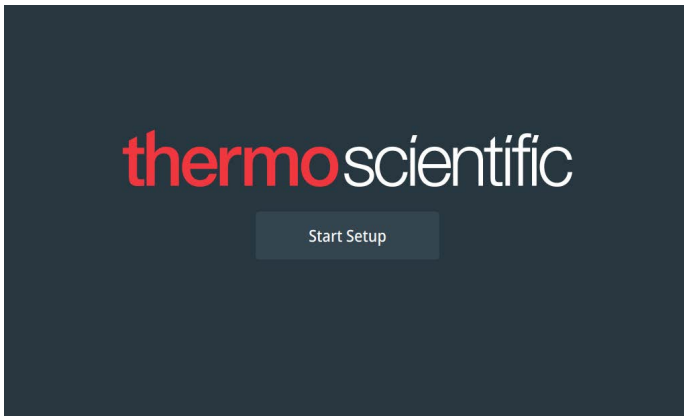

Figure 4. Main Screen

1. The first step of the setup is to select the language.
2. This screen allows you to specify the preferred display language.
3. Once the language is selected, press the Next button.

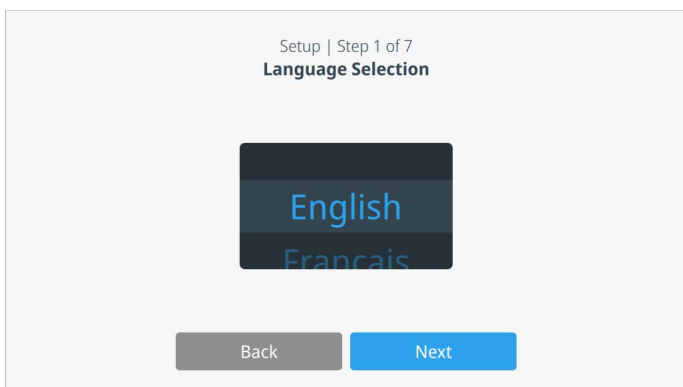

Figure 5. Language Selection Screen

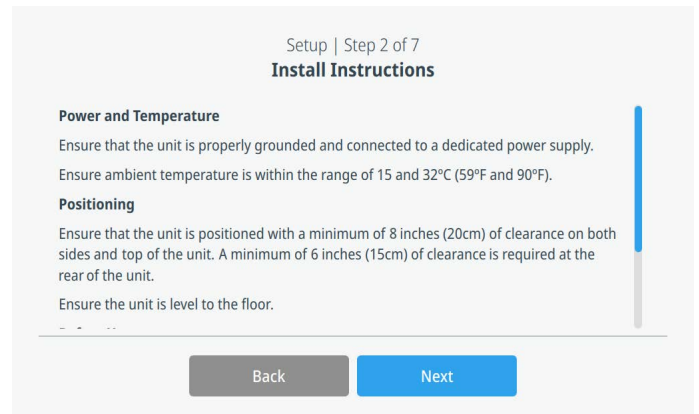

Figure 6. Install Instructions Screen

The Install Instructions Screen shows important information regarding:

1. Power source and ambient temperature conditions.
2. Unit positioning, spacing, and leveling.
3. Initial freezer loading.
4. Press the Next button after reviewing.

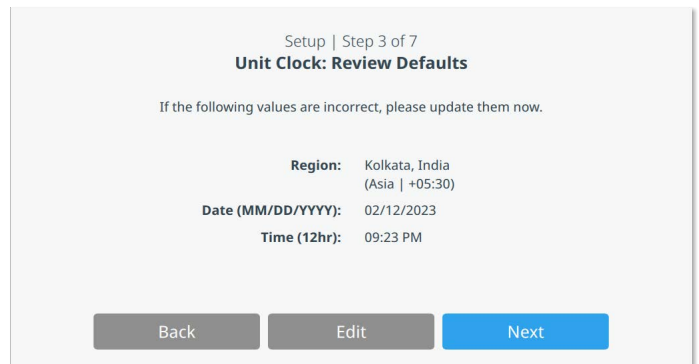

Figure 7. Unit Clock Setup Screen

1. This screen highlights the default date and time for the selected region.
2. Press the Edit button if change is needed. This opens the Set Region Screen.
3. If not, press the Next button after reviewing.

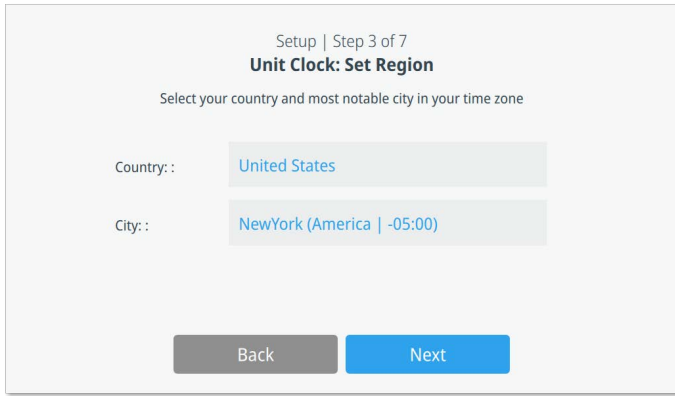

Figure 8. Set Region Screen (Optional)

When entering your “City” into Region Setup screen, refer to **Appendix C: City Time Zone**. Follow the table to select the city closest to your time zone.

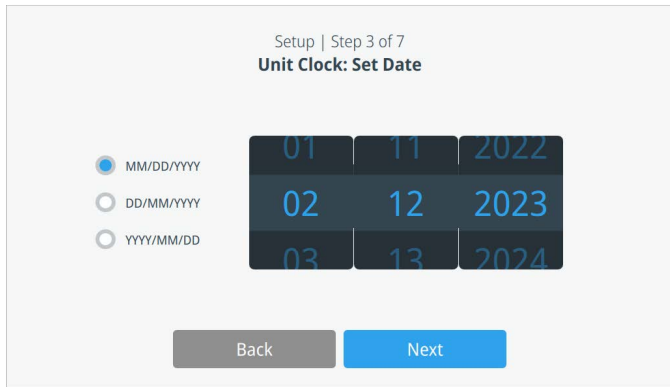

Figure 9. Unit Clock Screen

1. This screen allows you to set the Date and Date format.
2. Press the next button after reviewing.

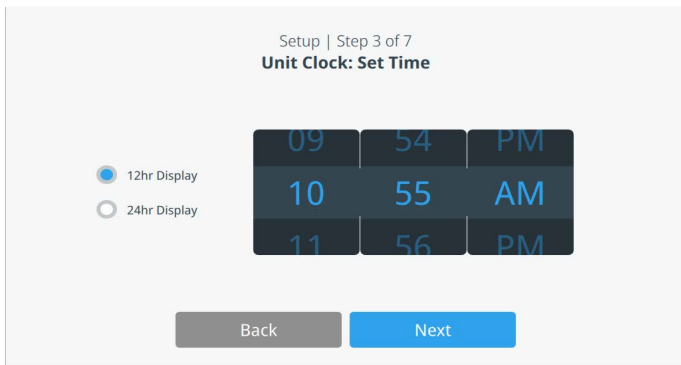

Figure 10. Unit Clock - Set Time Screen

1. This screen allows you to set the Time and Time format.
2. Press Next button after reviewing.

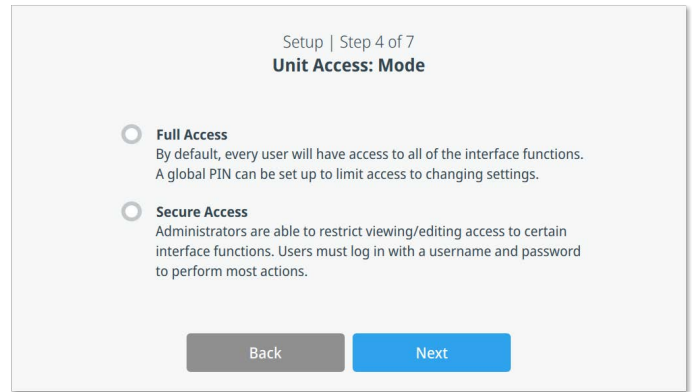

Figure 11. Unit Access Mode Screen

This screen allows you to specify the Access Mode. If Secure Access is selected, at least one administrative account must be created. After choosing the mode, press Next button to continue.

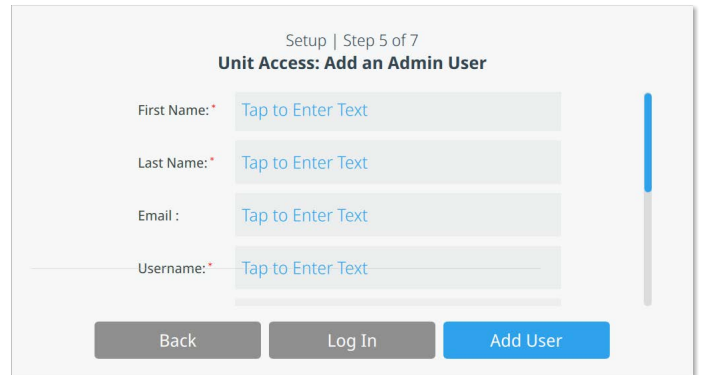

Figure 12. Add an Admin User Screen

This screen allows you to enter the admin user details of your first name, last name, email, and username to create admin account. Press the Add User button to continue.

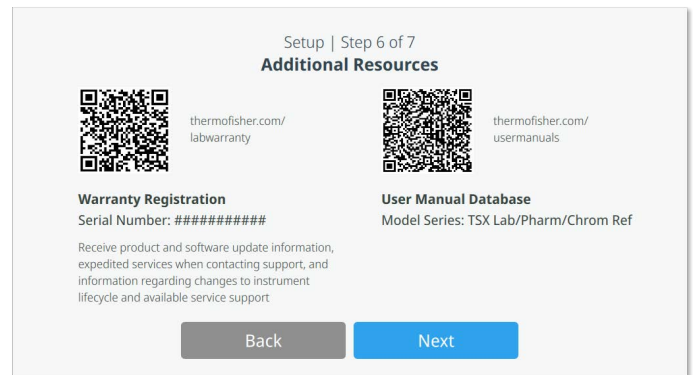

Figure 13. Additional Resources Screen

The Additional Resources screen shows QR codes that directs the user to Warranty Registration (<https://www.thermofisher.com/labwarranty>) and User Manual Database (<https://www.thermofisher.com/usermanuals>).

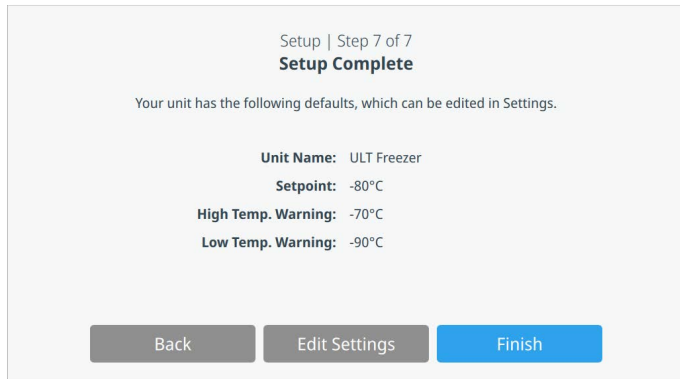

Figure 14. Units Setup Screen

The Setup Complete screen shows the default Unit Name (“ULT Freezer”) and setpoints (temperature, high temperature, and low temperature).

User can edit the default settings by pressing the Edit Settings button, otherwise press the finish button to complete the setup.

Operation

Operation Overview

Once you have successfully completed the initial startup procedures, the freezer starts operating normally and the only actions required are:

- Setting the operating and warning setpoints, refer to **Warnings**.
- Activating the CO₂ or LN₂ backup system, if installed. For instructions on backup settings and activating the system, refer to **Backup System (Optional)**.
- Adjusting settings on the undercarriage lighting system, if installed. Refer to **Undercarriage Lighting (Optional)**.

Home Screen

The Home Screen shown below is the default screen.

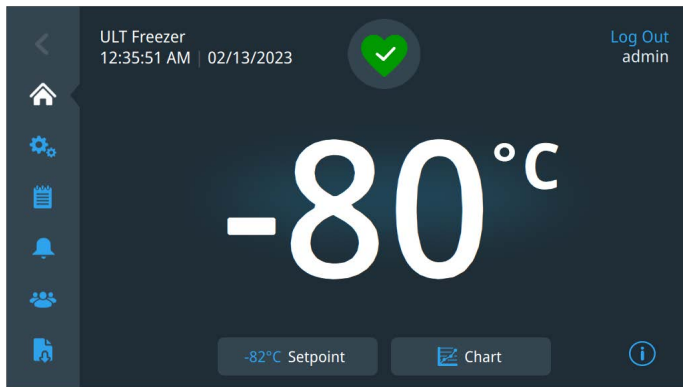

Figure 15. Home Screen

The various options available on the home screen are:

- The vertical panel on the left is the navigation bar that provides access to all functions of the unit.
- The colored icon in the middle indicates the health of the unit. There are 4 icons to denote this:
 - Green heart with a check mark indicates operation is normal.
 - Yellow triangle with an exclamation mark indicates a notification.
 - Red bell indicates a warning condition.
 - Red bell with a diagonal line indicates the warning has been snoozed.

- A login button to login into the system. This is only visible in Secure Access Mode. Refer to **User Login** for more information.
- The setpoint temperature is displayed. This can be changed by pressing the setpoint button at the bottom side of the screen.
- The temperature chart can be viewed by pressing the Chart button at the bottom of the screen. Refer to **Chart**.
- The ⓘ icon at the bottom right corner of the screen is the on-board help button. Press this icon to display a help box with text explaining all of the features available on that screen.
- The back button is the top button ("<") on the navigation bar and is used to navigate to the previous screen.

User Login

When the system is in Secure Access Mode, the user must login by entering their username and password.

When the system is running in Full Access mode, the login feature is restricted to service technicians to access the Service screens.

Settings

The second tab on the navigation panel is the Settings icon. The following screen is displayed when the Settings icon is selected. The screens corresponding to each option are described below.

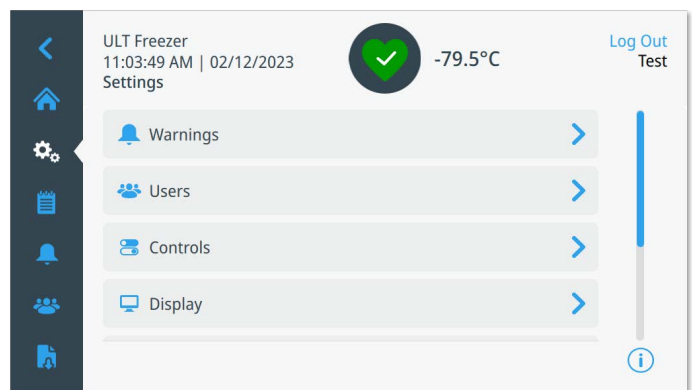

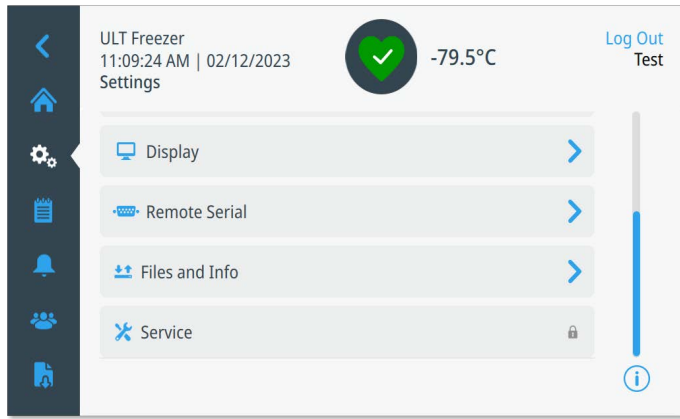

Figure 16. Settings Section

Warnings

The Warnings screen provides the option to set various temperature and time warning thresholds. Press the High Temperature or Low Temperature buttons to adjust the associated warning setpoints. For more information, refer to **Controls**.

- **Door Timeout:** Select a time period from 1 to 5 minutes. The Door Open warning will be activated when the freezer door remains open for a duration exceeding the specified timeout period.



Figure 17. Warning Screen

- **High temperature:** The range of the High Temperature warning setpoint is from 0 °C to within 5 °C of operating setpoint.

Note: The warm warning will be disabled for 12 hours from a warm start condition.

- **Low Temperature:** The range is -99 °C to within 5 °C of operating setpoint.
- **Snooze Timeout:** This sets the time to snooze the audible warning for an active warning. Select option from the dropdown menu and press the Save button to confirm changes.
- **Extreme Ambient:** This allows the user to set the extreme ambient caution setpoint. The range is 32 °C to 40 °C. Default is 37 °C.
- **Compressor Temperature:** This allows the user to set the Compressor Temperature caution setpoint. This caution is activated when the second stage compressor sump temperature exceeds the setpoint. The range is 70 °C to 98 °C. Default is 94 °C.

Users

The Users screen can also be accessed by using the User Icon on the left navigation bar. For more information, refer to **Users**.

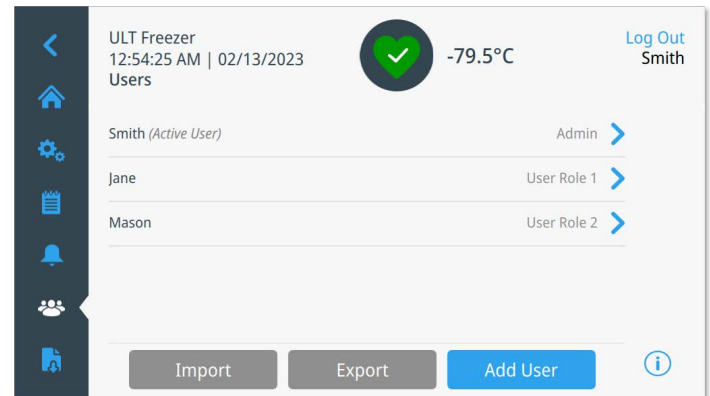

Figure 18. Users Section

Controls

The cabinet setpoint and other settings related to refrigeration system operation can be accessed from the Controls screen.

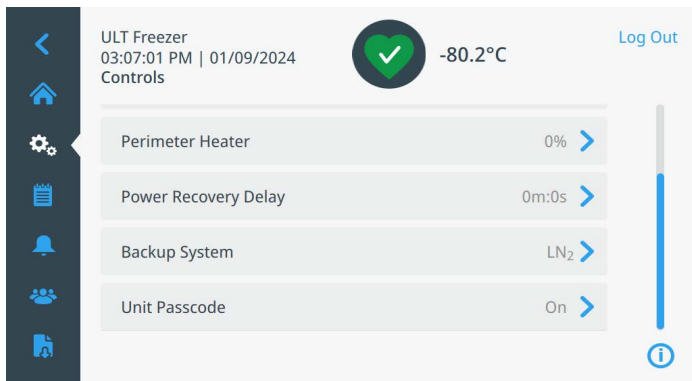
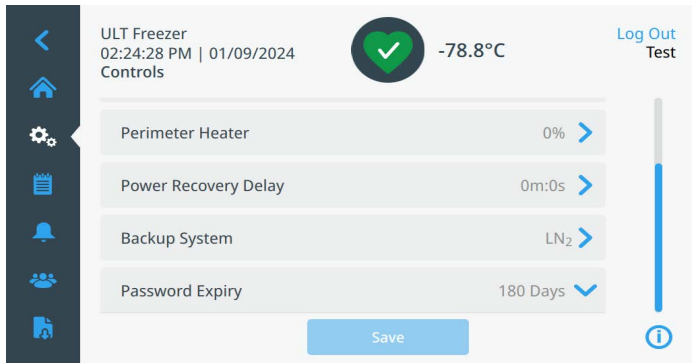

Figure 19. Controls Screen

- **Temperature Setpoint:** Press the Temperature Setpoint button to display the Setpoints screen:
- The setpoint and temperature warning parameters may be adjusted by swiping the spin control up / down or pressing the up / down arrows.

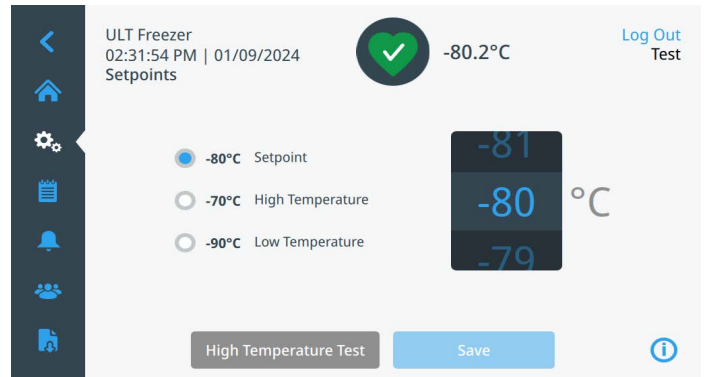

Figure 20. Setpoints Screen

- Control up / down or pressing the up / down arrows.
- Note:** A setpoint change may automatically change the warm and / or cold warning setpoints as well to prevent unnecessary warnings.
- After selecting the temperatures, press the Save button to confirm changes.
- Note:** If the save button is not pressed, the unit will not respond to the setpoint change request.

High Temperature Test: Pressing this button puts the system into a warm warning test which simulates a warm warning experience. Once this is selected, the home screen is displayed with the current temperature readout. The temperature display will increase to the warm warning temperature setpoint. Once the warm warning temperature is reached, the user is prompted to end the test.

Note: High Temperature Test cannot be performed until the unit attains first cycle setpoint or 12 hours have elapsed.

- **Temperature Offset:** This is used for calibration. Range is $-10\text{ }^{\circ}\text{C}$ to $+10\text{ }^{\circ}\text{C}$. Default is 0.
- **Perimeter Heater:** This is used to adjust the duty cycle of the built-in cabinet frame heater to reduce frost and ice around the cabinet frame. The range is from 0% to 100%. The default is 0%.

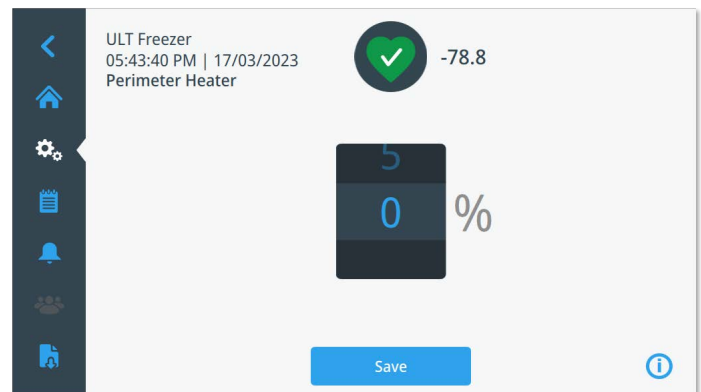

Figure 21. Perimeter Heater Screen

- **Power Recovery Delay:** Press this button to set the time delay upon startup after power failure. Default is 0.
- **Backup System:** This screen allows the user to select the backup setpoint for units with a backup system installed. For more information, refer to **Backup System (Optional)**.
- **Password Expiry (Secure Access mode):** Select from 60, 90, 120, 180 days for user password to expired. Press Save button to confirm change.
- **Unit Passcode (Full Access mode):** Press this button to assign a 4-digit passcode to a unit in Full Access mode. This passcode will be required to perform most setting changes on the unit. As an example, changing the unit's setpoint will require this passcode. To assign or update a passcode, enter 4 digits in the New Passcode fields. Enter the passcode again in the Confirm New Passcode fields. Press Save to confirm changes. To remove an active passcode from the unit, press the Remove Passcode button. Note this requires logging in with the previously set passcode. If the passcode is forgotten a Factory Reset will allow control of the system to be recovered.

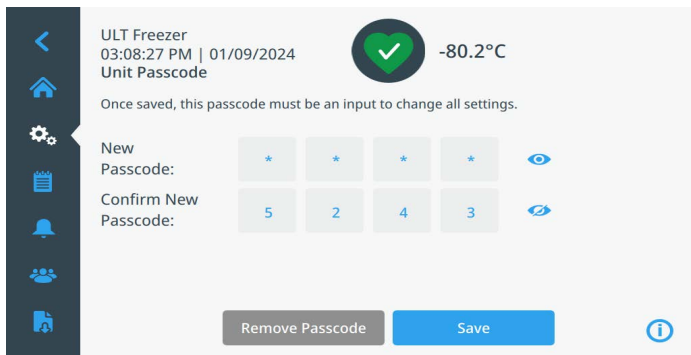

Figure 22. Unit Passcode Screen

Display

From the Settings screen, select the Display button to show the Display screen. Various display settings can be adjusted.

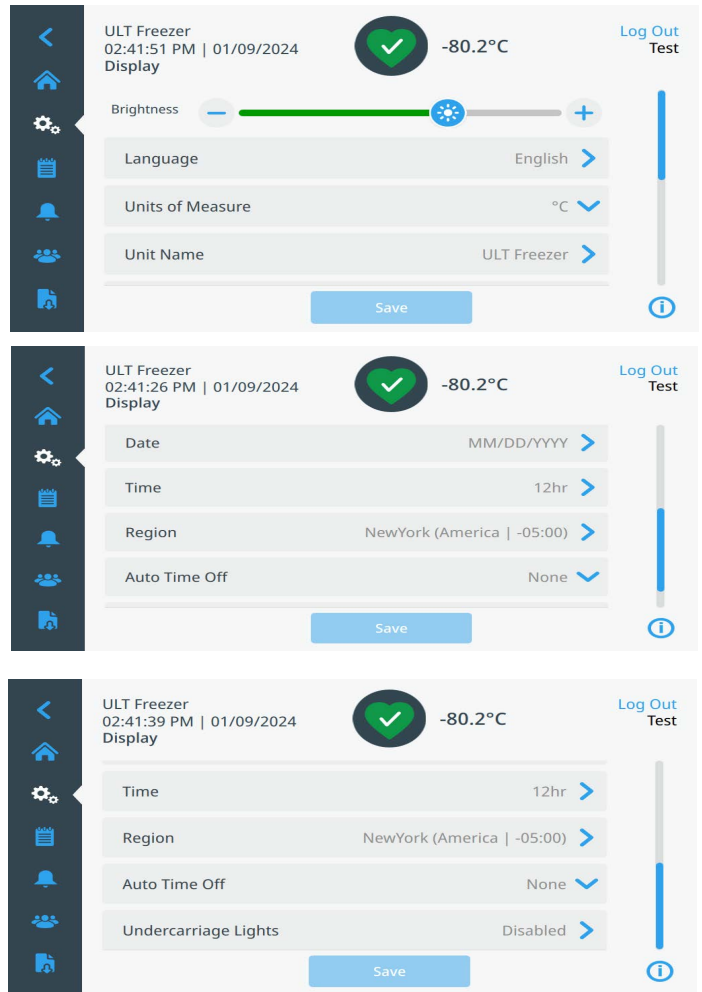

Figure 23. Display Screen

- **Brightness:** Use the slide control or the +/- buttons to adjust the brightness level of the display. Press the Save button to confirm changes.
- **Language:** To change the display language, press the Language button and select the desired language.
- **Units of Measure:** To change the displayed unit of measure select °C or °F from the dropdown and press the Save button to confirm changes.
- **Unit Name:** To enter or change the unit's name, press the Unit Name button.
- **Date:** To set the date and the date format, press the Date button.
- **Time:** To set the time and time format, press the Time button.

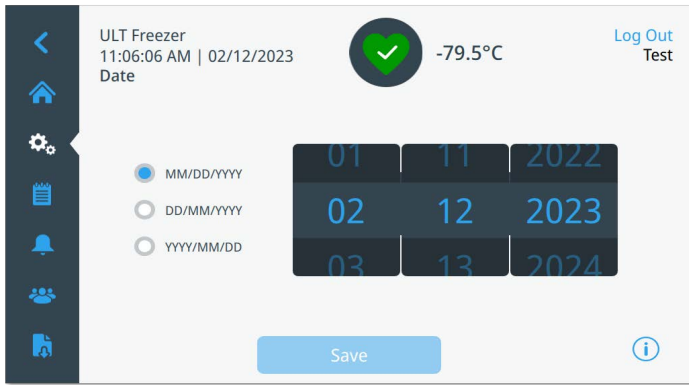

Figure 24. Date Screen

- **Region:** This is used to set the region and time zone the unit is operating from.
- **Auto Time Off:** Select the time range for when the LCD will automatically darken. The default option None, will leave the LCD constantly illuminated.
- **Undercarriage Lights:** If option is installed, you can enable or disable the undercarriage lighting system. Refer to **Modification of Undercarriage Lights Settings** for details.

Remote Serial

The Remote Serial screen allows the rear serial port to be configured for the **RS-485** or **Modbus ASCII** protocols. The Modbus ASCII protocol allows the user to read certain system values, such as Thermocouple and RTD temperatures. When configuring the **Modbus ASCII** protocol the device address and the serial baud rate can be set. Registers that are currently accessible through this protocol are shown in **Appendix D: Modbus ASCII (Read Only) Parameter Table**.

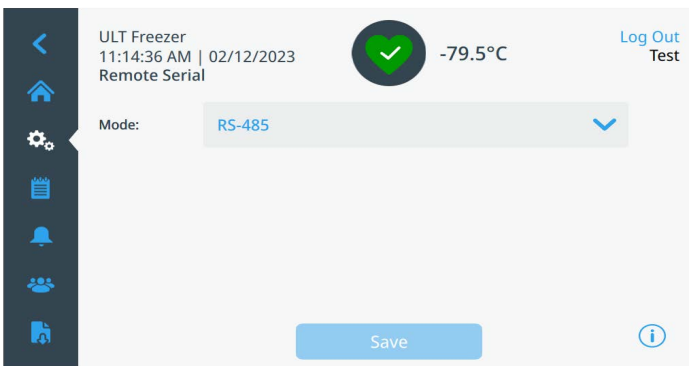

Figure 25. Remote Serial Screen

Files and Info

The following screen is displayed when the Files and Info button is selected:

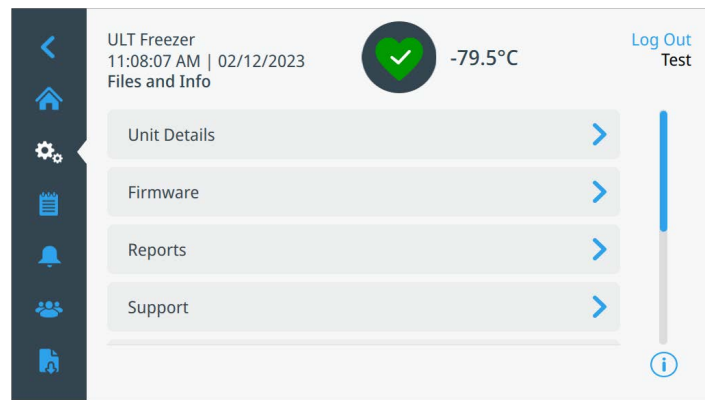

Figure 26. Files and Info Screen

- **Unit Details:** Summary of unit info and software version.
- **Firmware:** User interface application upgrade. Contact technical service for details.
- **Reports:** This is used to export temperature and event data. A date range can be provided. Refer to **Reports** for more details.

- **Support:** Press this button to view the service contact information.
- **User Manual:** QR Code/Link to download the user manual.
- **Warranty Registration:** QR code / Link to perform warranty registration.
- **Configuration Files:** This is used to export or import configuration files. Configuration files may be uploaded to other freezers. A passphrase will be required to export or import configuration files.

Note: The imported setpoint and offset must be verified by the user after the import.

- **Factory Reset:** Select to reset the settings, including temperature setpoint to factory defaults. This is the only method to change the Access Mode.

Event Log

The third tab on the navigation panel is the event log that contains a record of user and system events. The Event Log screen will be displayed once the Event Log icon is pressed. This screen displays up to 2 weeks of recent events with date time stamps for each event.

The Date/Time and Event columns can be sorted in an ascending or descending order by selecting the column header.

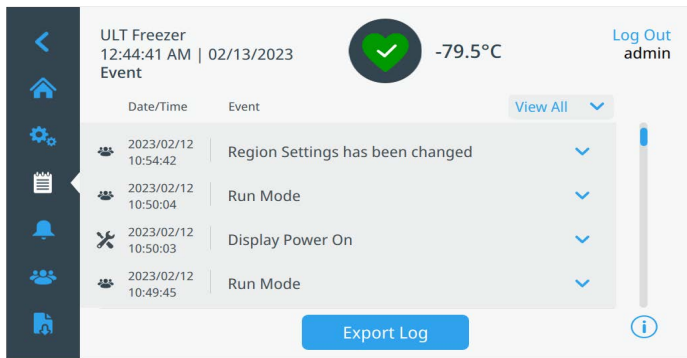

Figure 27. Event Log Screen

Additional information of an individual event can be viewed by selecting the event.

There is a drop-down list based on the event types. The event types can be filtered and categorized into: Warning, Door, User, Battery, and Backup. When a filter is selected, the View All button on the right changes to Filter ON.

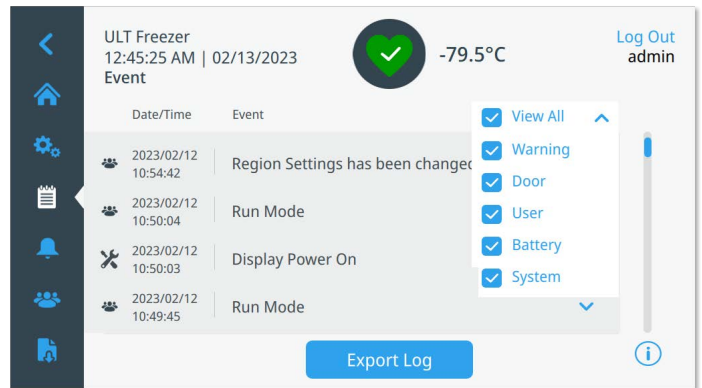

Figure 28. Event Log Screen with Filter

Press the Export Log button to export system data to a USB drive. Refer to **Reports** for details.

Warnings

By selecting the warning tab, the Warning Settings screen is displayed. For more information on setpoints, refer to **Warnings**.

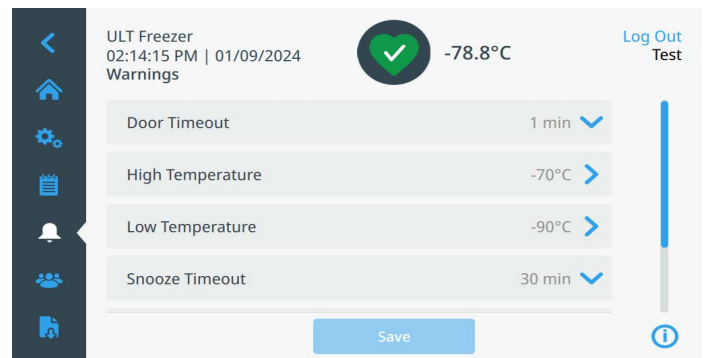

Figure 29. Warning Settings Screen

Users

The User tab is used to display the Users screen. This screen is only accessible in Secure Mode. Use this screen add to a user to the system or import and/or export the user database. The following screen is displayed when the User icon is selected:

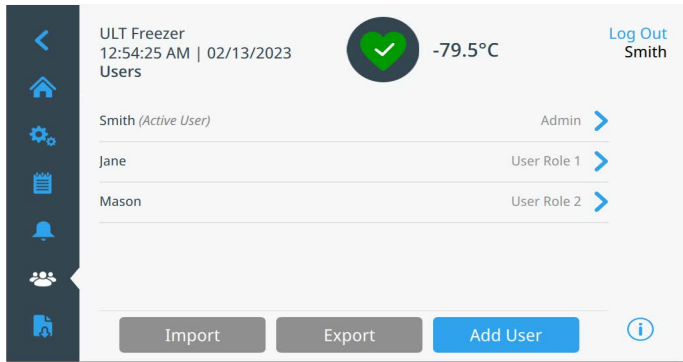

Figure 30. Users Screen

The Import button allows a user database to be imported.

Note: The database to be imported must originate from another unit running identical software; otherwise, the system will be unable to recognize the database.

The user database can be exported using the Export button. A USB drive must be inserted for the data to be transferred.

Adding New Users

Press the Add User button to navigate to the Add a User screen:

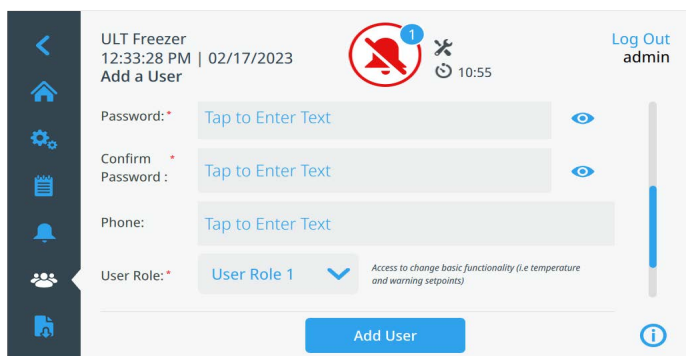
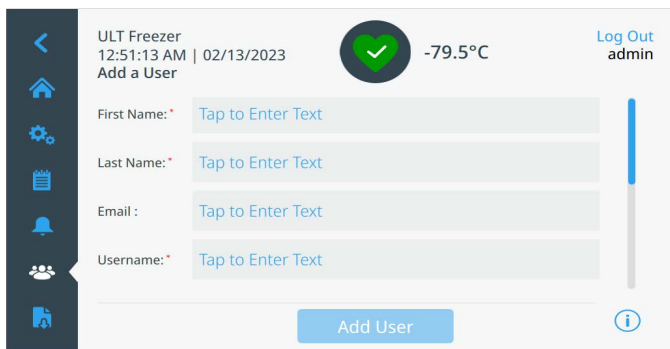

Figure 31. Add a User Screen

Fill in the information in the fields and press Add User. A '*' denotes a required field.

- **First Name:** Enter the user's first name.
- **Last Name:** Enter the user's last name.
- **Email:** Enter the user's email address.
- **Username:** Enter the username for this user. A default will appear based upon the email address entered.
- **Password/Confirm Password:** Enter and confirm a user password. The password entered must be 6-12 characters long, have at least 1 uppercase, 1 lowercase, 1 number and 1 special character.
- **Phone:** Enter a user's telephone number.
- **User Role:** Select the access level for the user.
 - **Admin:** This user has access to change settings and manage profiles.
 - **User Role 1:** This user has access to change basic functionality such as temperature and warning setpoints.
 - **User Role 2:** This user can view the temperature and warning information but cannot change the settings (Primarily used when unit is equipped with HID Access ID, as anyone needing access to the freezer must have a user role).
- **Access ID:** Refer to **Managing Access Cards**.

Editing and Deactivating Users

To edit an existing user, press the user entry in the Users screen and the Edit User Details screen will be displayed. Make the required edits by selecting the appropriate field and changing the information. After making the changes, press the "Save" button and confirm.

To reset a user's password, press the Reset Password button. After confirmation dialog, a temporary PIN is displayed. Record this PIN and provide to the user. It will be used by the user to reset their password.

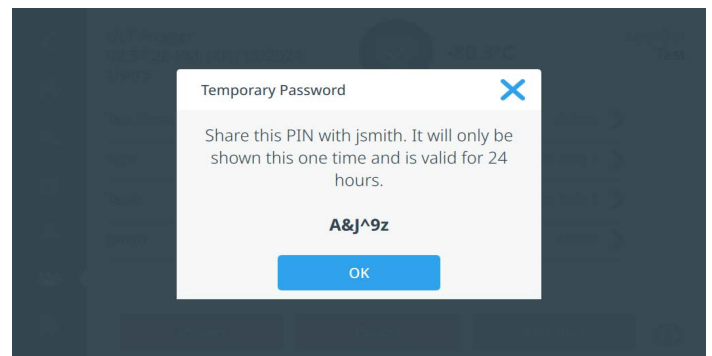

Figure 32. Resetting a user's password

To deactivate a user, press the Deactivate button. A deactivated user can be reactivated by pressing the user entry in the Users screen and pressing the Activate button.

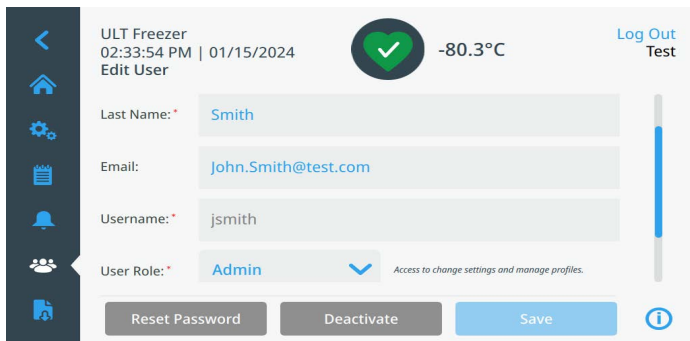
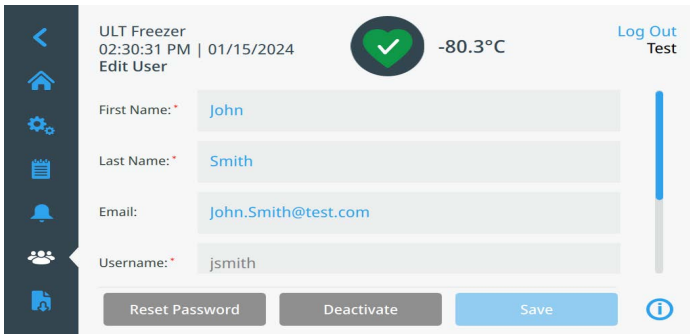

Figure 33. Edit User Screen

Managing Access Cards

When the Access Card system is installed, the Edit User screen allows assigning cards to each user. Users may then swipe their access card to gain access to the freezer or login.

To associate an access card to a selected user, press the Access ID field of the Edit User screen and hold the card at the bottom center of the LCD screen. The Access ID field will automatically be populated and there will be a beep. Only one card may be added per user. The Access ID must be unique for each user.

Reports

The Report tab is used to export a log or report. The Export Logs and Reports screen will be displayed when the Report icon is pressed. If PDF is selected as the Export type, the date range is limited to 2 options - 1 week (default) and 1 day.

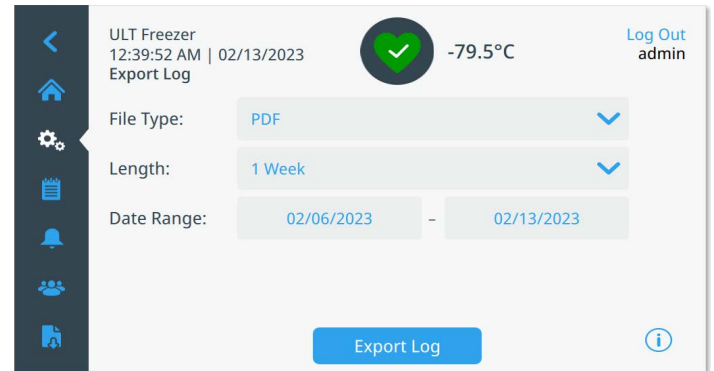
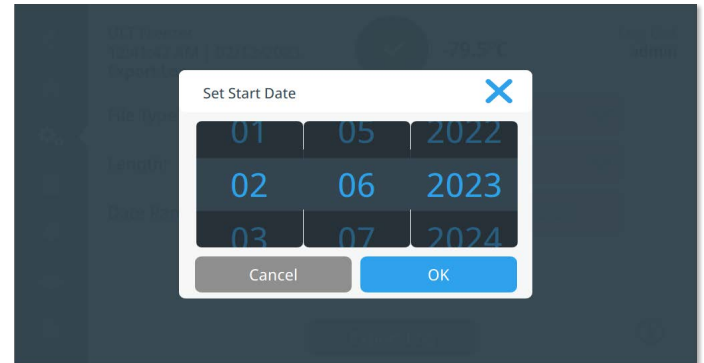
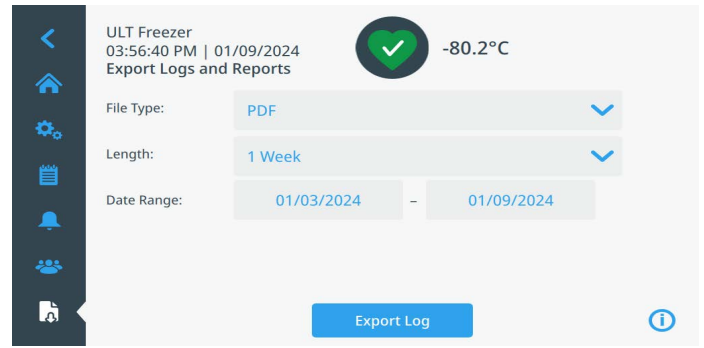

Figure 34. Export Logs and Reports Screen

To export event and temperature logs,

1. Choose the item to be exported from Export drop down list. The options available are Event and Temperature Log, Event Log, Temperature Log and Reports.
2. Select the export format of the log or report.
3. A predefined or custom date range may be selected.
4. A USB drive must be inserted to store the log or report. Press the Export Log button to download the log or report.

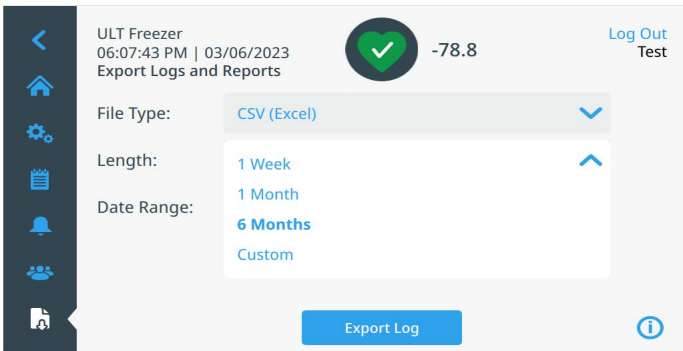
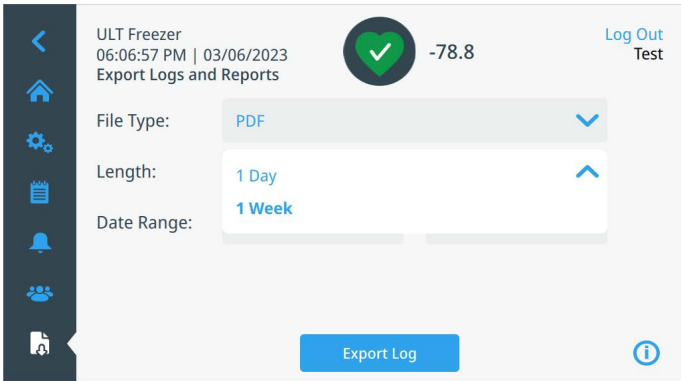
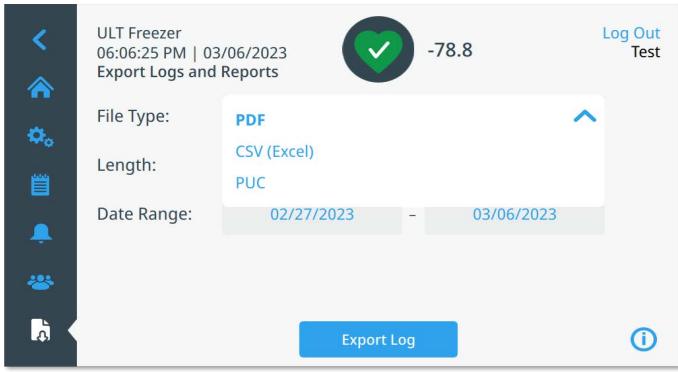

Figure 35. Export Log Screen

Chart

The Chart screen shows the unit temperature over recent history. 12, 24, and 72 hour ranges can be selected for the chart. Events are displayed over the chart aligned on the x-axis at the time that they occur. Additional unit data can be exported using the Export button.

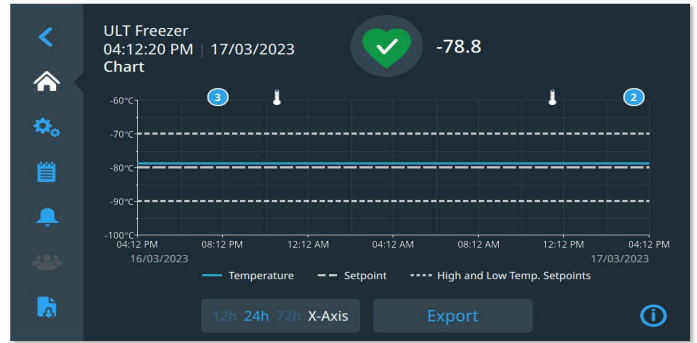







Figure 36. Chart

Event Icons

Icons related to events will appear on the top of the chart.

| Icon | Description |
|---|---------------------|
|  | Door Open |
|  | Power Failure |
|  | Temperature Warning |
|  | Service |
|  | Multiple Events |

Power Off and Standby Mode

There is a standby power button on the front of the unit. When pressed and held for approximately 3 seconds, the user is prompted to confirm that the unit will be placed into Standby mode.



CAUTION: In Standby mode, the refrigeration system shuts down and the unit will not cool.

To restore normal operation, the standby power button must be pressed and held for approximately 1 second. To fully power off the unit, while in Standby mode move the breaker switch to the OFF position.

Note: Standby mode should not be used for more than 48 hours. Powering off the unit will conserve more energy than leaving a unit in Standby mode.

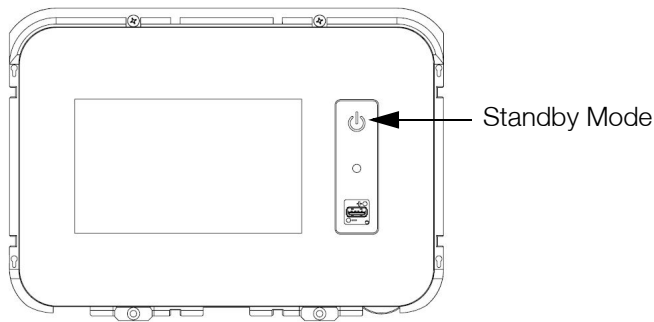

Figure 37. Standby Button

Health Status and Warning Management

Health Status Overview

Selecting the Health Status (green heart) icon in the home screen displays the following screen:

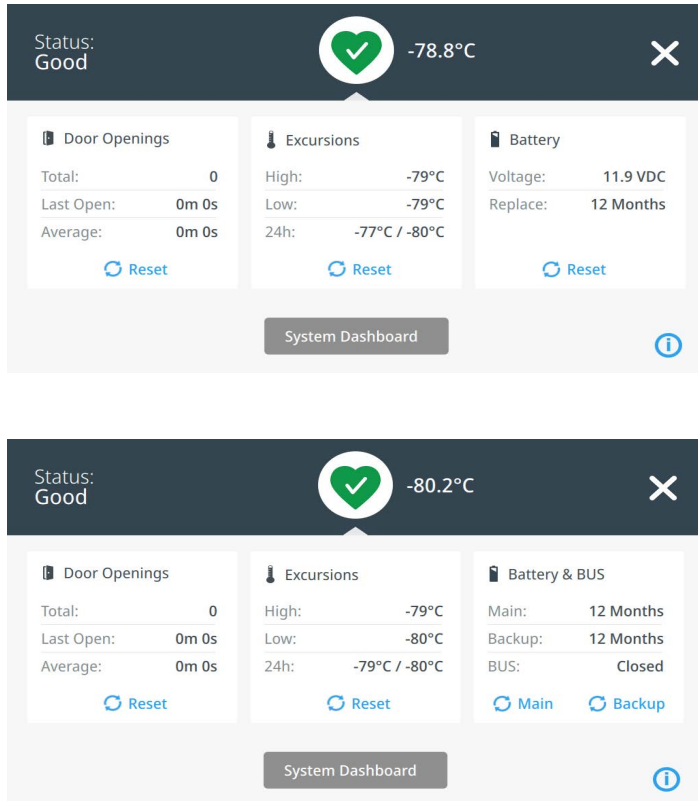

Figure 38. Health Status Screen

- **Door Openings:** Total displays the number of times the door has been opened since the last reset. Last Open displays the duration the door was last opened. Average displays the average duration of all door openings since the last reset. Press the Reset icon to reset the door opening values to 0.
- **Excursions:** High and Low display the highest and lowest cabinet temperatures, respectively, recorded since the last reset. 24h displays the highest and lowest temperatures in the last 24 hours. Press the Reset icon to clear excursions and set High and Low values to the current cabinet temperature.
- **Battery:** This section is displayed on units without a BUS. Voltage displays the system battery voltage. Replace displays the amount of time before battery

replacement is recommended. Press the Reset icon after replacing the system battery to reset the replacement countdown timer.

- **Battery & BUS:** This section is displayed on units with a Backup System (BUS). Main displays remaining time before system battery replacement is recommended. Backup displays remaining time before BUS battery replacement is recommended. BUS displays the current status of the BUS system. When the BUS is actively cooling the status will change from "Closed" to "Injecting". If the pressure switch detects an empty tank the status will show as "Empty".

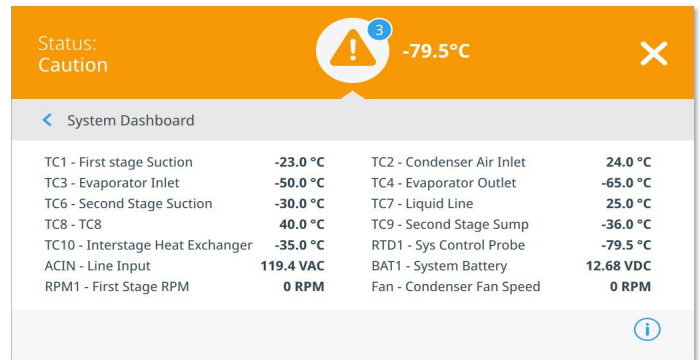

Figure 39. System Dashboard Screen

The system dashboard shows the live data of various monitoring devices in the system including temperatures, RPMs, AC voltage, and battery levels. When a BUS is present, the BUS RTD and BUS battery values are also displayed.

Notifications / Cautions

In the event of a notification, the green heart is replaced by a yellow triangle icon. The number in the blue circle indicates the total number of notifications.

A yellow triangle on the home screen indicates less serious caution conditions, such as extended door openings and warnings that occurred in the past.

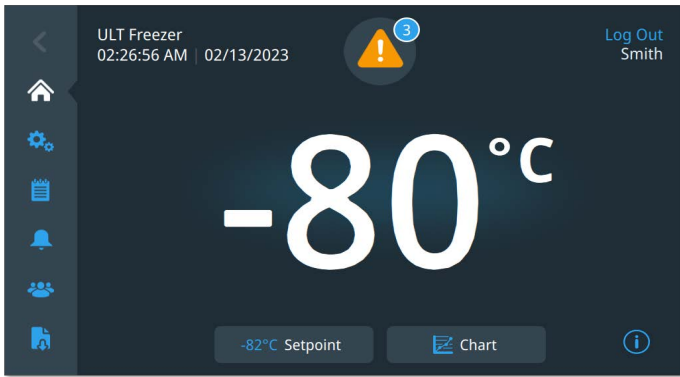

Figure 40. Home Screen with Notification / Caution

Press the yellow triangle to display additional notification details.

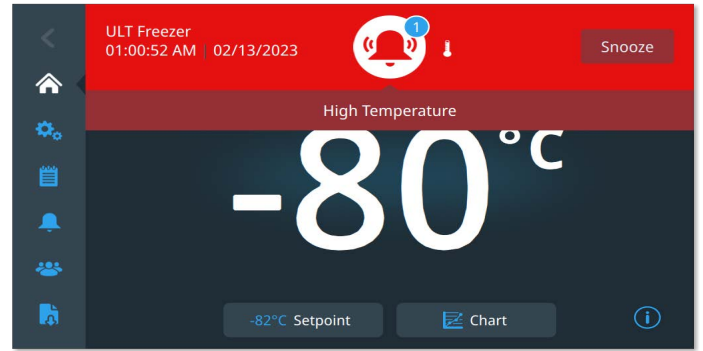

Figure 42. Home Screen with Caution / Warning

Press the red bell for additional information about the warnings.

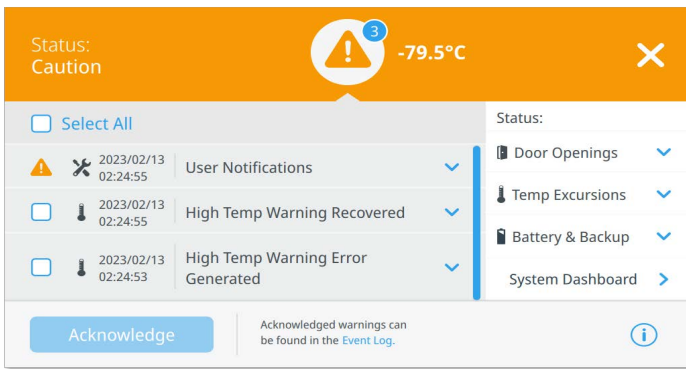

Figure 41. Notification / Caution Details

The Acknowledge button is highlighted in blue once a notification is selected by pressing the adjacent check box. The notification will be displayed until it is acknowledged. There is a link to the Event Log beside the Acknowledge button.

On the right panel, the Health Status details can also be viewed.

Warning / Cautions

In the event of a warning condition, the green heart or yellow triangle is replaced by a red bell icon. A red bell warning on the home screen indicates a serious warning condition which must be corrected, such as a warm warning or a power failure.

The warning can be silenced by pressing the Snooze button or the Red Bell icon which will mute the warning for a duration set in the Snooze Timeout setting.

The number in the blue circle indicates the total number of warnings. The icon(s) to the right of the bell helps identify the warning type. The ticker message provides warning details.

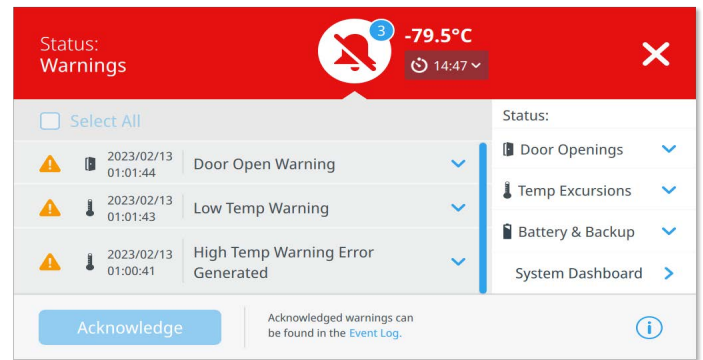

Figure 43. Caution / Warning Detail Screen

If a warning and a notification occur at the same time, the warning red bell icon is displayed, and the list includes both warnings and notifications.

The Acknowledge button becomes highlighted in blue once a warning is selected by pressing the adjacent checkbox. Active warnings cannot be cleared until the issue is addressed. There is a link to the Event Log beside the Acknowledge button.

On the right panel, the Health Status details can also be viewed.

For more information on various warning conditions, refer to **Appendix A: Warning / Caution Summary**.

Backup System (Optional)

When you purchase a built-in CO₂ or LN₂ optional backup system for the freezer, backup control is integrated into the main user interface.



Note: Always purchase the cylinders which are equipped with siphon tubes for withdrawing liquid from the bottom of the cylinder. CO₂ cylinders must be kept at room temperature to function properly. LN₂ bottles are functional at any reasonable temperature.

CO₂ and LN₂ Precautions

The following are precautions for using liquid CO₂ and LN₂ backup systems.



CAUTION: For models ordered with factory installed built-in backup systems, the flow of liquid CO₂ or LN₂ will be discontinued if the door is opened during operation of the backup system. For units operated with free-standing, field installed type backup system, the flow of liquid CO₂ or LN₂ will be discontinued upon door opening only if the switch provided with the free-standing package is installed on the freezer.



CAUTION: When closing the cylinder valve, ensure that the injection solenoid is energized to allow all the liquid to bleed off instead of being trapped in the supply hose. Failure to do this results in activation of the pressure relief device, which could damage the freezer and requires replacing if it is activated.



WARNING: CO₂ and LN₂ liquids are poisons but are very cold and will burn unprotected skin. Always wear protective eye wear and clothing when changing cylinders or working on the piping systems attached to an active source of liquid refrigerant.



DANGER: If a CO₂ or LN₂ cylinder falls and a valve is knocked off, the cylinder becomes a deadly and completely unguided missile. Transport the cylinders in a hand-truck or cart with secure chain ties for the cylinder. After cylinders are connected to the equipment, securely attach them with chains to a solid, stationary object such as a building column.



DANGER: The gases produced by evaporation of CO₂ or LN₂ are non-poisonous but displace the oxygen in a confined space and can cause asphyxiation. Do not store the cylinders in subsurface or enclosed areas.

Installation

Field installed systems are supplied with complete installation and operating instructions. If your system is factory installed, the freezer is shipped with a coiled length of hose to connect the freezer to the bottles:

- 1/4 inches Flexible Hose with fittings for connection to the CO₂ supply.
- 1/2 inches Flexible Hose with fittings for connection to the LN₂ supply.

To install:

1. Straighten the coiled hose.
2. Connect one end to the labeled connection on the freezer.
- Tighten the nut 2 flats past finger tight, approximately 120 degrees.

Note: For CO₂, remove the threaded fitting from the nut on the end of the copper tubing to access nut for connection to the freezer. Discard the threaded fitting.

3. Attach the other end to the supply bottle or building supply fitting.

For CO₂:

- Remove Nipple from adapter (NPT Connection). Remove cable tie to release alternative nut and washer. Ensure the correct nut fitting is supplied over the nipple (US or European).
- Add 2 wraps of Teflon tape clockwise to the 1/4 inches NPT fitting (on the nipple) when viewed from the threads. Tighten the NPT fittings approximately 2 turns from finger tight (approximately 720°).

Note: The top of the nipple has a hex configuration, allowing for use of a wrench when the nut is pulled down.

- Add washer to nipple inside of nut (unless CO₂ supply has a built-in washer).

Note: Small raised area of washer fits into groove of nipple. The washer will feel snug when trying to shift side to side on nipple. The washers are designed for a limited number of attachments/disconnections from the supply and may wear overtime. If washer appears worn and causes CO₂ leakage, replace washer (Part Number 45705H03).

- Wrench tighten the supply nut to the supply.
- **For LN₂:**
 - Attach the fitting to the supply and wrench tighten.



CAUTION: Do not twist, torque, or subject the flexible hose to sharp bends. Doing so may shorten the life of the hose.

Start Up

To activate the backup system:

1. Follow instructions in the Startup section to turn on the freezer and set temperature and warning setpoints.
2. Set backup setpoint or perform test injection on the Backup System screen below, which can be accessed through the Controls option in the Settings tab. Details on test injections are covered in Operation section. (Refer to **Figure 20**).
3. To change the backup system type contact service.

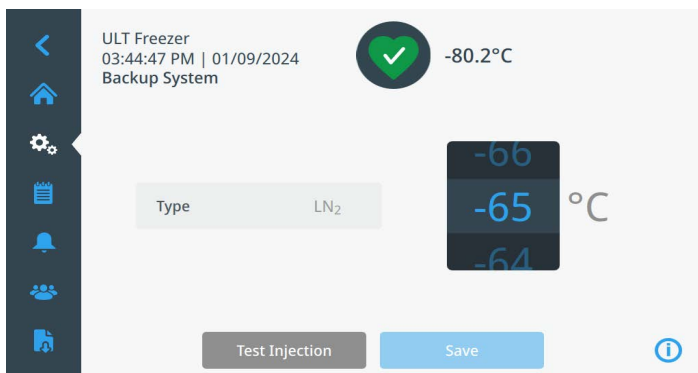

Figure 44. Backup System Settings Screen

4. Press the Save button to save the changes made.

Operation

When the backup system is in operation, the parameters can be viewed and configured on the settings screen.

This backup system can be tested by pressing the Test Injection button. The system will inject for approximately 10 seconds. During this test, injection can be stopped by pressing the button again. After a test injection has completed, the button will become inactive for approximately 50 seconds to prevent excessive cooling.

The backup system will last for a minimum of 24 hours on battery power given proper battery maintenance is followed detailed in Battery Maintenance section.

On average, a backup system in operation uses 8 to 10 lbs. per hour of CO₂ (3.6 to 4.5 L/hr.) or LN₂ (4.5 to 5.6 L/hr.) at an ambient temperature of 25 °C.

Chart Recorders (Freestanding)

Chart Recorder information can be found here:



Undercarriage Lighting (Optional)



Figure 45. Undercarriage Lighting

Undercarriage lighting is intended to provide additional visual indication of the freezer health status. The lighting displayed is synchronized with the health status indication displayed on the freezer's user interface.

There are 3 colors that may be displayed in the undercarriage system:

- Green (healthy)
- Orange (caution)
- Red (warning)

For a list of all warnings and cautions, refer to **Appendix A: Warning / Caution Summary**.

In the event of a Power Failure, the undercarriage lighting system will automatically turn off to conserve main battery life while maintaining user interface temperature display.

Modification of Undercarriage Lights Settings

Turning undercarriage lights on and off:

1. Go To Settings > Display > Undercarriage Lights.
2. Enable or Disable LED Lights.

Turning green (healthy status) lights on and off:

1. Go To Settings > Display > Undercarriage Lights.
2. Enable or Disable Green Light Indication.

Running green health lights can reduce the life expectancy of the LED light system.

Disconnecting the Undercarriage Light System

To physically disconnect the undercarriage lighting system, disconnect the harness connection located behind the front grill housing shown in **Figure 46**. This may be necessary if moving a larger unit through a doorway.

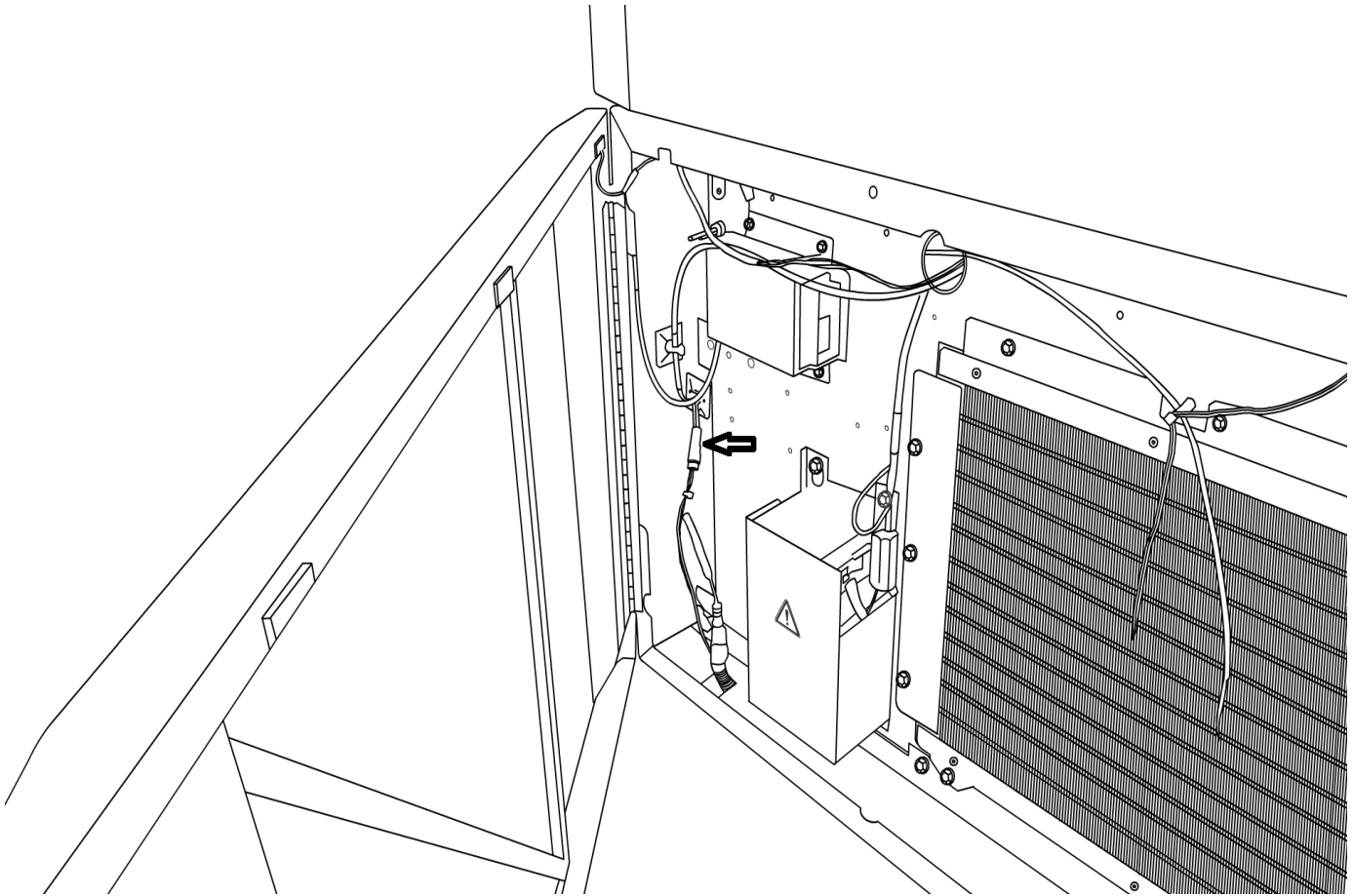

Figure 46. Disconnecting the Undercarriage Light System

Maintenance and Troubleshooting



CAUTION: Maintenance should only be performed by trained personnel.



WARNING: Unauthorized repair of your freezer will invalidate your warranty. Contact Technical Service at 1-800-438-4851 for additional information.

Cleaning the Exterior

Clean the exterior of the freezer as needed. If misting or spraying be careful around the user interface area and avoid spraying upward.

Compatible cleaning agents include the following: Mild detergent, Hydrogen Peroxide, Acetic Acid, Ammonium cleaning solutions, and 70% Isopropyl alcohol.

Cleaning the Condenser



CAUTION: Condensers should be cleaned at least every 6 months; more often if the laboratory area is dusty. In heavy traffic areas condensers load with dirt more quickly. Failure to keep the condenser clean can result in equipment warm-up or erratic temperatures.



CAUTION: Risk of cut. Never clean around the condensers with your fingers. Some surfaces are sharp.

Clean the condenser at least every 6 months; more often if the laboratory area is dusty.

To clean the condenser, complete the following steps:

1. Pull the grille door open.
2. Vacuum the condenser.
3. Inspect the filter cleanliness and clean as required.
4. Close the grille door.

Cleaning the Condenser Filter

Clean the condenser filters every 2 or 3 months.

There are 2 condenser filters: a main filter and a lower filter for extra air flow into the condenser.

1. Pull the grille door open.
2. Remove the filters.
3. Shake the filters to remove loose dust, rinse the filters in clean water, shake the excess water from the filters, and replace the filters.
4. Close the grille door.

Gasket Maintenance

Periodically check the gaskets around the door for punctures or tears. Leaks are indicated by a streak of frost which forms at the point of gasket failure. Ensure that the cabinet is level. (Refer to **Installation**).

Keep the door gaskets clean and frost free. Wipe with a soft cloth or cryo-gloved hand. If needed, a rubber mallet may be gently used to loosen ice.

Defrosting the Freezer

Defrost the freezer once per year or whenever the ice buildup exceeds 3/8 inches. To defrost, complete the following steps:

1. Remove all products and place in another ULT cabinet.
2. Turn off the freezer. Using standby mode and then removing power.
3. Open the outer door and all inner doors.
4. Let the freezer stand with doors open for at least 24 hours. This allows both the interior and foamed refrigerant system to warm to room temperature.
5. Dispose of the ice and wipe out any water standing in the bottom of the cabinet.
6. Clean the interior with a Compatible cleaning agents include the following: Mild detergent, chlorine, Hydrogen Peroxide, Peracetic Acid, Acetic Acid, Quaternary ammonium cleaning solutions, and 70% Isopropyl alcohol.
7. Close the doors, restart the freezer, and reload. Refer to **Initial Loading**.

Battery Maintenance

The freezer monitors the voltage status of the battery daily and indicates a battery failure via visual and auditory warning. Replace the battery as indicated by system warnings or as necessary per individual status evaluation. Check the battery connections regularly. Although not required, annual battery replacement is recommended to ensure proper battery status in the event of power failure. Be sure to reset the battery replacement timer via the user interface whenever the battery is replaced.

For safety, it is recommended to power off the unit and disconnect it from the power source before replacing the battery. Battery terminals are color coded red and black. Ensure the corresponding colored wires are connected to the matching color terminals on the battery. The battery is installed with terminals oriented toward the condenser compartment or hinge side of the freezer's outer door (see below). With proper installation, the red wire should be connected to the rear battery (positive) terminal and the black wire to the front (common) terminal.

Failure to properly connect the battery can damage electrical components and potentially hinder normal operation of the freezer. Consult a certified service technician if there are any questions or concerns about battery maintenance.

Battery Specification

Rechargeable sealed lead-acid battery, 12 V, 7.0 Amp Hr. Replacement batteries can be purchased directly from Thermo Fisher Scientific (part number 400159).

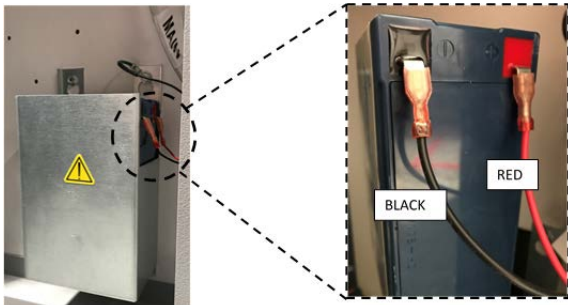

Figure 47. Battery Specification

Maintenance Schedule

Regular maintenance is important to keep the unit working properly. Inspect/Clean as directed in the table below.

| Item | Interval |
|-----------------------------------|--|
| Defrost | Defrost the freezer once per year or whenever the ice build exceeds 3/8 inches (0.95 cm). |
| Gasket | Periodically check the gaskets around the door for punctures or tears. Periodically clean the ice-build up around the gasket. |
| Filter | Clean the condenser filter(s) every 2 to 3 months. |
| Condenser | Clean every 6 months; more often if the laboratory area is dusty. |
| Battery | Replace the battery as indicated by system warnings or as necessary per individual status evaluation. Check the battery connections regularly. Although not required, annual battery replacement is recommended to ensure proper battery status in the event of power failure. |
| Undercarriage lighting (optional) | Every 2 to 3 months, clean any dust or debris that has accumulated on the surface of the lighting housing. |

Troubleshooting Guide

This section is a guide to troubleshooting general operational problems.

| Problem | Cause | Solution |
|--|---|--|
| Unit warming. Unit set to $-80\text{ }^{\circ}\text{C}$ but cannot make temperature (Not reaching setpoint). Unit recovers slowly to setpoint. | Warm load / Overload. | Allow ample time to recover from loading warm product. Do not overload cabinet. Refer to Initial Loading in user manual for loading procedures. |
| | Hot environment. | Check, if the location meets ambient requirements (within $32\text{ }^{\circ}\text{C}$ to $40\text{ }^{\circ}\text{C}$ or $90\text{ }^{\circ}\text{F}$ to $104\text{ }^{\circ}\text{F}$) and away from hot objects. |
| | Dirty condenser and condenser filter. | Clean condenser and filter. Refer to Cleaning the Exterior and Cleaning the Condenser Filter in user manual. |
| | Not enough space for air circulation. | Install the unit in a level area free from vibration with a minimum of 8 inches (20 cm) of space on the top and sides, 6 inches (15 cm) in back. |
| | Icing/Frost due to high relative humidity. | Check if the location meets requirements. Maximum relative humidity 60% for temperatures within $15\text{ }^{\circ}\text{C}$ to $32\text{ }^{\circ}\text{C}$ ($59\text{ }^{\circ}\text{F}$ to $90\text{ }^{\circ}\text{F}$). |
| | Excess frost build-up in chamber. | Defrost the unit. Refer to Defrosting the Freezer in user manual. |
| | Frost build-up on outer door gasket. | Wipe with a soft cloth or cryo-gloved hand. |
| | Gasket damage. | Check for punctures or tears on gasket. Replace if necessary. Refer to Gasket Maintenance in user manual. |
| | Prolonged door openings. | Avoid opening of door for longer duration. Allow ample time for recovery after door opening. |
| | Inadequate power supply. | Check for proper voltage and currents are supplied to the unit. |
| User interface (Display) failure. | Breaker switch off. | Check circuit breaker and reset to on position. Always use a dedicated, properly grounded circuit. |
| | User interface not powered on. Unit power failure. | Push power button  on user interface and hold for at least 1 second . |
| | Unit power failure | Apply proper power to the unit. |
| Unit is ON but display is showing empty. | User interface not powered on. Try restarting the unit manually by flipping the breaker at the front of the unit. If this does not work, call service. | Push power button  on user interface and hold for at least 1 second . Try touching the screen. |
| Display is looking dull. | Screen brightness is too low. | From the settings screen, pressing the display button will show the display. Adjust the brightness level of the display (Refer to Users). |

| Problem | Cause | Solution |
|--|---|---|
| Power failure to the unit. | Power supply stopped / Breaker switch off. | Confirm that the cord is securely plugged in. |
| | | Plug another appliance into the outlet to see if power is present. |
| Power failure to the unit. | Panel unable to supply voltage during power failure recovery of multiple units. | Reset circuit breaker to on position and push power button  on user interface and hold for at least 1 second . Always use a dedicated, properly grounded circuit. For the TSX series, the ULT should not be connected to a GFCI (Ground Fault Circuit Interrupter) protected outlet as it may be subject to nuisance tripping. |
| | | Use different power recovery delay settings per unit. Refer to Users Section . |
| Unit tripping the circuit breaker. | Shared power source. | Never connect unit to overloaded power source. Always use a dedicated (separate) circuit. |
| | Unit plugged into wrong power outlet. | Plug the unit into proper power source to deliver correct voltage and current. |
| | Unit not grounded. | Your unit must be properly grounded in conformity with national and local electrical codes. Troubleshooting procedures involving live voltage is dangerous and if done improperly can result in injury and/or death. This troubleshooting should be performed by trained personnel only. |
| | Use of GFCI for TSX units. | For the TSX series, the ULT should not be connected to a GFCI (Ground Fault Circuit Interrupter) protected outlet as it may be subject to nuisance tripping. |
| | Use of extended cords. | Do not use an extension cord. Ensure the unit supplied power cord is plugged directly into power outlet. |
| | Panel unable to supply voltage during power failure recovery of multiple units. | Use different power recovery delay settings per unit. Refer to Users Section . |
| Excessive frost build-up around perimeter of door. | Icing/Frost due to high relative humidity. | Check if the location meets requirements. Maximum relative humidity 60% for temperatures within 15 °C to 32 °C (59 °F to 90 °F). Occasionally scrape the ice on the outer door. |
| | Excessive and prolonged door openings. | Avoid opening door for a prolonged time. |
| | Gasket damage. | Check for punctures or tears on gasket. Replace if necessary. Refer to Gasket Maintenance . |
| Unit is over cooling. | Setpoints may have changed. | Adjust the setpoint to run at desired setpoint under settings. Refer to Factory Reset in Files and Info . |
| | Temperature offset may have changed. | Try adjusting the offset. Temperature offset can be set in the Controls screen under settings. Refer to Factory Reset in Files and Info . |
| | Unknown. | Try restarting the unit. If this does not help call service. |

| Problem | Cause | Solution |
|--|---|--|
| Unit compressors run continuously. | Freezer setpoint is low. | Compressor may run continuously at colder setpoint depending on the ambient to optimize for energy consumption and temperature peak variation. |
| | Frost build up. | Defrost the unit. Refer to Defrosting the Freezer . |
| | Dirty condenser. | Clean the condenser and condenser filter. |
| | Gasket damage. | Check for punctures or tears on gasket. Replace if necessary. Refer to Gasket Maintenance . |
| Cabinet temperature reached a warning condition, but suitable warning is not activated. | Warning setpoints may be changed. | Check the present setpoints for temperature warning conditions. Change the setpoints if required. Refer to Settings Section . |
| Problem with temperature validation/calibration. | Cabinet temperature displayed does not match with actual temperature. | The display is not designed to show the temperature where the probe is located. It is designed to approximate the cabinet average temperature. There can be significant difference between the cabinet and probe temperature. |
| Unit is experiencing too much cabinet temperature fluctuation (high uniformity / peak variation). | Heater duty cycle set to High. | Reduce the Perimeter Heater duty cycle. Verify exterior door sealed completely. Refer to Files and Info (Factory Reset). |
| | Exterior door is closed but not sealed completely. | Clean any ice build-up on gasket and / or cabinet surface. Check for punctures or tears on gasket. Replace if necessary. Refer to Gasket Maintenance . |
| Unit is constantly warning. | Exterior door is closed but not sealed completely. | Clean any ice build-up on gasket and / or cabinet surface. Check for punctures or tears on gasket. Replace if necessary. Refer to Gasket Maintenance . |
| | Warning icons appear on user interface home screen. | Tap the red bell icon or the yellow triangle. The ticker messages on the icons provide warning and recovery details. Refer to Warning / Cautions . |
| | Door open warning, exterior door not closing completely. | Open door completely and immediately close and latch it. |
| | Door open warning, exterior door is closed but not sealed completely. | Defrost exterior door gasket and make sure the door is completely sealed. |
| | Warning setpoints may have changed. | Change the setpoints as required. Refer to Settings Section . |
| Unit cycle on-percentage is increasing or compressor RPMs are elevated (applicable only to warmer setpoints) | Ambient conditions. | Unit performance is directly impacted by these causes mentioned. Warm load or overload caused by a leak in the system. Once temperature is stable, cycle dynamics should return to normal range. Try maintaining ambient conditions, reducing load, reducing door openings. If issues persist, call service. |
| | Warm load (or) overload. | |
| | Frequent and prolonged door openings. | |

| Problem | Cause | Solution |
|---|---|--|
| Difficult to close / open the outer door. Outer door alignment issues. | Unit is not level. | Level the unit. Refer to Leveling section. |
| | Frost accumulated on outer door gasket. | Wipe with a soft cloth or cryo-gloved hand. |
| | Door latch problem. | Ensure door latch is securing. Lubricate the door latch mechanism. |
| | Pressure Equalization Port (PEP) malfunctioning | The PEP is located behind the user interface, but the backside of the port can be seen on the inside surface of the exterior door. If the opening or area directly in front of the opening is filled or covered with ice and/or frost, remove the blockage. Try closing and re-opening the door. If issues persist, call service. |
| Difficult to close / open the inner door. | Frost accumulated around inner door. | Defrost the inner door. Consider increasing door Perimeter Heater duty cycle. |
| Vibration noise. Rattling noise/ Loud noise. | Unit is not level. | Check if the unit is installed in a level area free from vibration. Refer to Leveling section. |
| | Loose side panels. | Check side panel screws, tighten them if necessary. |
| | Rubber tubing separators and/or compressor dampeners may have loosened. | Call service. |
| Undercarriage lights not displaying. | Undercarriage lighting is not enabled. | Check to ensure the LED lighting is enabled in the settings menu. Modification of Undercarriage Lights Settings. Ensure the light is installed since this is a customer install option. |
| | Lighting is not connected. | Check to ensure lighting harness is connected. To find this harness connection, see Disconnecting the Undercarriage Light System. Try unplugging and re-plugging in this harness. |
| | Improper hardware installation. | Call service. |
| | LED failure. | Call service for LED replacement. |

Warranty

Be sure to register your warranty online:

www.thermofisher.com/labwarranty

THERMO FISHER SCIENTIFIC USA FREEZER WARRANTY FOR TSX SERIES

The Warranty Period starts two weeks from the date your equipment is shipped from our facility. This allows for shipping time so the warranty will go into effect at approximately the same time your equipment is delivered. The warranty protection extends to any subsequent owner during the warranty period.

During the first five years of the warranty period, component parts proven to be non-conforming in materials or workmanship will be repaired or replaced at Thermo Fisher Scientific's expense, labor included. The ULT Freezers include an additional seven year warranty on the compressors, parts only, F.O.B. factory. Installation and calibration are not covered by this warranty agreement. The Technical Services Department must be contacted for warranty determination and direction prior to any work being performed. Expendable items, i.e., glass, filters, pilot lights, light bulbs and door gaskets are excluded from this warranty.

Replacement or repair of component parts or equipment under this warranty shall not extend the warranty to either the equipment or to the component part beyond the original five year warranty period. The Technical Services Department must give prior approval for the return of any components or equipment.

THIS WARRANTY IS EXCLUSIVE AND IN LIEU OF ALL OTHER WARRANTIES, WHETHER WRITTEN, ORAL, OR IMPLIED. NO WARRANTIES OF MERCHANTABILITY OR FITNESS FOR A PARTICULAR PURPOSE SHALL APPLY. Thermo shall not be liable for any indirect or consequential damages including, without limitation, damages relating to lost profits or loss of products.

Your local Thermo Fisher Scientific Sales Office is ready to help with comprehensive site preparation information before your equipment arrives. Printed instruction manuals carefully detail equipment installation, operation, and preventive maintenance.

If equipment service is required, call your Technical Services Department at 1-800-438-4851 (USA and Canada). We are ready to answer your questions on equipment warranty, operation, maintenance, service, and special applications. Outside the USA, contact your local Thermo Fisher Scientific office or distributor for warranty information.

Warranty (International)

THERMO FISHER SCIENTIFIC FREEZER INTERNATIONAL WARRANTY FOR TSX SERIES

The Warranty Period starts two months from the date your equipment is shipped from our facility. This allows for shipping time so the warranty will go into effect at approximately the same time your equipment is delivered. The warranty protection extends to any subsequent owner during the warranty period. Dealers who stock our equipment are allowed an additional four months for delivery and installation, providing the warranty card is completed and returned to the Technical Services Department.

During the first five years of the warranty period, component parts proven to be non-conforming in materials or workmanship will be repaired or replaced at Thermo Fisher Scientific's expense, labor excluded. The ULT Freezers include an additional seven year warranty on the compressors, parts only, F.O.B. factory. Installation and calibration are not covered by this warranty agreement. The Technical Services Department must be contacted for warranty determination and direction prior to any work being performed. Expendable items, i.e., glass, filters, pilot lights, light bulbs and door gaskets are excluded from this warranty.

Replacement or repair of component parts or equipment under this warranty shall not extend the warranty to either the equipment or to the component part beyond the original five year warranty period. The Technical Services Department must give prior approval for the return of any components or equipment.

THIS WARRANTY IS EXCLUSIVE AND IN LIEU OF ALL OTHER WARRANTIES, WHETHER WRITTEN, ORAL, OR IMPLIED. NO WARRANTIES OF MERCHANTABILITY OR FITNESS FOR A PARTICULAR PURPOSE SHALL APPLY. Thermo shall not be liable for any indirect or consequential damages including, without limitation, damages relating to lost profits or loss of products.

Your local Thermo Fisher Scientific Sales Office is ready to help with comprehensive site preparation information before your equipment arrives. Printed instruction manuals carefully detail equipment installation, operation, and preventive maintenance.

If equipment service is required, contact your local Thermo Fisher Scientific office or local distributor.

We are ready to answer your questions on equipment warranty, operation, maintenance, service, and special applications. Outside the USA, contact your local Thermo Fisher Scientific office or distributor for warranty information.

End of Life Care

Some considerations and suggestions are listed below for proper disposal of this product. While addressing these actions for safe recycling and disposal, please follow all guidelines, Safety Data Sheets (SDS), or regulations applicable to your country and region.

This product has materials and components that may be recycled or reused according to local guidelines and regulations.

Remove any batteries present before disposal. Batteries, battery packs, and accumulators should not be disposed of as unsorted household waste. Please use the public collection system to return, recycle, or treat them in compliance with the local regulations.

Remove all samples and items before defrosting a unit to room ambient temperatures.

Clean up any chemical or biological safety hazards using appropriate methods.

Remove the cabinet door to help prevent entrapment inside of a unit.

Have a certified technician remove the refrigerant and compressor, drain the compressor and oil from the system, and dispose properly. Note that oil may be infused with refrigerant and should be handled with care by someone experienced with refrigerants used in this product, as listed on the serial data plate.

Have a certified technician remove the Refractory Ceramic insulation from the unit then dispose properly.

Appendix A: Warning / Caution Summary

| Warning/ Caution Summary | | | | | |
|--|-------------|--------------|---------------|------------------|---|
| Warning/ Caution | Tone | Heart | Remote | Ring-back | Message Details |
| Bus Battery Disconnected Warning | High | Red | Yes | Yes | <p>Header: BUS Battery Disconnected Warning</p> <p>Details: BUS Battery Disconnected Warning active. Bus will be unable operate during a power failure. May take up to 4 hrs. to clear even with a new battery.</p> <p>Ticker: BUS Battery Disconnected.</p> |
| Bus Battery Disconnected Warning Recovered | None | Yellow | None | None | <p>Header: BUS Battery Disconnected Warning Recovered</p> <p>Details: BUS Battery Disconnected Warning has recovered. BUS battery reconnected. Select check box and press Acknowledge to clear this notification.</p> <p>Ticker: None</p> |
| BUS Battery Low Caution | None | Yellow | None | None | <p>Header: BUS Battery Low Caution</p> <p>Details: BUS battery is low. Recommend replacing battery. Contact customer service for replacement battery. May take up to 4 hrs. to clear even with a new battery.</p> <p>Ticker: None</p> |
| BUS Battery PM Expiry Caution | None | Yellow | None | None | <p>Header: BUS Battery PM Expiry Caution</p> <p>Details: Recommend replacing the BUS battery. Reset battery expiration time using the status screen to clear this notification.</p> <p>Ticker: None</p> |
| BUS Lost Communication Warning | High | Red | Yes | Yes | <p>Header: BUS Lost Communication Warning</p> <p>Details: BUS Lost Communication Warning active. A BUS communication error has occurred. Contact customer service.</p> <p>Ticker: BUS Lost Communication</p> |
| BUS Lost Communication Warning Recovered | None | Yellow | None | None | <p>Message Header: BUS Lost Communication Warning Recovered</p> <p>Message Details: A BUS communication error has recovered. Select check box and press Acknowledge to clear this notification.</p> <p>Ticker Message: None</p> |

| Warning/ Caution Summary | | | | | |
|---|-------------|--------------|---------------|------------------|--|
| Warning/ Caution | Tone | Heart | Remote | Ring-back | Message Details |
| BUS Probe Failure Warning | High | Red | Yes | Yes | <p>Header: BUS Probe Failure Warning</p> <p>Details: BUS Probe Failure Warning active. Check that bus battery is connected. Contact customer service.</p> <p>Ticker: BUS Probe Failure</p> |
| BUS Probe Failure Warning Recovered | None | Yellow | None | None | <p>Header: BUS Probe Failure Warning Recovered</p> <p>Details: BUS Probe Failure Warning has recovered. Select check box and press Acknowledge to clear this notification.</p> <p>Ticker: None</p> |
| Clean Filter Caution | None | Yellow | None | None | <p>Header: Clean Filter Caution</p> <p>Details: Clean the filter and condenser. If unable to clear this caution, contact customer service.</p> <p>Ticker: None</p> |
| Compressor Temperature Caution | None | Yellow | None | None | <p>Header: Compressor Temperature Caution</p> <p>Details: The second stage sump temperature has exceeded the setpoint of XX [CF]. Contact customer service.</p> <p>Ticker: None</p> |
| Configuration Failure Warning | High | Red | Yes | Yes | <p>Header: Configuration Failure Warning</p> <p>Details: Configuration Failure Warning active. [Error code: XX.] Contact customer service.</p> <p>Ticker: Configuration Failure</p> |
| Configuration Failure Warning Recovered | None | Yellow | None | None | <p>Header: Configuration Failure Warning Recovered</p> <p>Details: Configuration Failure Warning has recovered. Select check box and press Acknowledge to clear this notification.</p> <p>Ticker: None</p> |
| Control Probe Failure Warning | High | Red | Yes | Yes | <p>Header: Control Probe Failure Warning</p> <p>Details: Control Probe Failure Warning active. The freezer will continue to operate using other sensors or in full run mode. Contact customer service.</p> <p>Ticker: Control Probe Failure</p> |

| Warning/ Caution Summary | | | | | |
|---|-------------|--------------|---------------|------------------|--|
| Warning/ Caution | Tone | Heart | Remote | Ring-back | Message Details |
| Control Probe Failure Warning Recovered | None | Yellow | None | None | <p>Header: Control Probe Failure Warning Recovered</p> <p>Details: Control Probe Failure Warning has recovered. Select check box and press Acknowledge to clear this notification.</p> <p>Ticker: None</p> |
| Door Open Warning | High | Red | Yes | Yes | <p>Header: Door Open Warning</p> <p>Details: Door Open Warning active. A door open for greater than X minutes will cause door open warning. X minutes is set by user.</p> <p>Ticker: Door Open</p> |
| Door Open Warning Recovered | None | Yellow | None | None | <p>Header: Door Open Warning Recovered</p> <p>Details: Door Open Warning has recovered. Select check box and press Acknowledge to clear this notification.</p> <p>Ticker: None</p> |
| Evaporator Inlet Probe Failure Warning | High | Red | Yes | Yes | <p>Header: Evaporator Inlet Probe Failure Warning</p> <p>Details: Evaporator Inlet Probe Failure Warning active. Expect increased recovery time. Contact customer service.</p> <p>Ticker: Evaporator Inlet Probe Failure</p> |
| Evaporator Inlet Probe Failure Warning Recovered | None | Yellow | None | None | <p>Header: Evaporator Inlet Probe Failure Warning Recovered</p> <p>Details: Evaporator Inlet Probe Failure Warning has recovered. Select check box and press Acknowledge to clear this notification.</p> <p>Ticker: None</p> |
| Evaporator Outlet Probe Failure Warning | High | Red | Yes | Yes | <p>Header: Evaporator Outlet Probe Failure Warning</p> <p>Details: Evaporator Outlet Probe Failure Warning active. Expect increased recovery time. Contact customer service.</p> <p>Ticker: Evaporator Outlet Probe Failure</p> |
| Evaporator Outlet Probe Failure Warning Recovered | None | Yellow | None | None | <p>Header: Evaporator Outlet Probe Failure Warning Recovered</p> <p>Details: Evaporator Outlet Probe Failure Warning has recovered. Select check box and press Acknowledge to clear this notification.</p> <p>Ticker: None</p> |

| Warning/ Caution Summary | | | | | |
|---|-------------|--------------|---------------|------------------|--|
| Warning/ Caution | Tone | Heart | Remote | Ring-back | Message Details |
| Extreme Ambient Caution | None | Yellow | None | None | <p>Header: Extreme Ambient Caution</p> <p>Details: Ambient temperature has exceeded the Extreme Ambient setpoint of XX [CF]. Ensure room temperature is properly controlled.</p> <p>Ticker: None</p> |
| Fan Low RPM Warning | High | Red | Yes | Yes | <p>Header: Fan Low RPM Warning</p> <p>Message: Fan Low RPM Warning active. Condenser fan may require maintenance. Ensure fan is free of dust and debris.</p> <p>Ticker: Fan Low RPM</p> |
| Fan Low RPM Warning Recovered | None | Yellow | None | None | <p>Header: Fan Low RPM Warning Recovered</p> <p>Details: Fan Low RPM Warning has recovered. Select check box and press Acknowledge to clear this notification.</p> <p>Ticker: None</p> |
| Firmware Build Incompatible Warning | High | Red | Yes | Yes | <p>Header: Firmware Build Incompatible Warning</p> <p>Details: Firmware Build Incompatible Warning active. The firmware build indicates incompatibility that can result in modules to be non-coherent.</p> <p>Ticker: Firmware Build Incompatible</p> |
| Firmware Build Incompatible Warning Recovered | None | Yellow | None | None | <p>Header: Firmware Build Incompatible Warning Recovered</p> <p>Details: Firmware Build Incompatible Warning recovered. Select check box and press Acknowledge to clear this notification.</p> <p>Ticker: None</p> |
| Hardware Failure Warning | High | Red | Yes | Yes | <p>Header: Hardware Failure Warning</p> <p>Details: Hardware Failure Warning active. A hardware component has failed. System may not be able to maintain setpoint. Contact customer service.[Error code: XX.]</p> <p>Ticker: Hardware Failure</p> |
| Hardware Failure Warning Recovered | None | Yellow | None | None | <p>Header: Hardware Failure Warning Recovered</p> <p>Details: Hardware Failure Warning has recovered. Select check box and press Acknowledge to clear this notification.</p> <p>Ticker: None</p> |

| Warning/ Caution Summary | | | | | |
|---|-------------|--------------|---------------|------------------|--|
| Warning/ Caution | Tone | Heart | Remote | Ring-back | Message Details |
| Heat Exchange Probe Failure Warning | High | Red | Yes | Yes | <p>Header: Heat Exchange Probe Failure Warning</p> <p>Details: Heat Exchange Probe Failure Warning active. The freezer will continue to operate but expect increased temperature variation and recovery times. Contact customer service.</p> <p>Ticker: Heat Exchange Probe Failure</p> |
| Heat Exchange Probe Failure Warning Recovered | None | Yellow | None | None | <p>Header: Heat Exchange Probe Failure Warning Recovered</p> <p>Details: Heat Exchange Probe Failure Warning has recovered. Select check box and press Acknowledge to clear this notification.</p> <p>Ticker: None</p> |
| High Temperature Warning | High | Red | Yes | Yes | <p>Header: High Temperature Warning</p> <p>Details: High Temperature Warning active. The freezer temperature has exceeded the high temperature warning set point of XX [CF]. Prolonged door openings and warm product loading may cause a high temperature warning.</p> <p>Ticker: High Temperature</p> |
| High Temperature Warning Recovered | None | Yellow | None | None | <p>Header: High Temperature Warning Recovered</p> <p>Details: The freezer temperature has recovered from a high temperature warning event. Select check box and press Acknowledge to clear this notification.</p> <p>Ticker: None</p> |
| Low Temperature Warning | High | Red | Yes | Yes | <p>Header: Low Temperature Warning</p> <p>Details: Low Temperature warning active. The freezer temperature has exceeded the low temperature warning set point of XX [CF].</p> <p>Ticker: Low Temperature</p> |
| Low Temperature Warning Recovered | None | Yellow | None | None | <p>Header: Low Temperature Warning Recovered</p> <p>Details: The freezer temperature has recovered from a low temperature warning event. Select check box and press Acknowledge to clear this notification.</p> <p>Ticker: None</p> |

| Warning/ Caution Summary | | | | | |
|-------------------------------------|-------------|--------------|---------------|------------------|--|
| Warning/ Caution | Tone | Heart | Remote | Ring-back | Message Details |
| Power Failure Warning | High | Red | Yes | Yes | <p>Header: Power Failure Warning</p> <p>Details: Power Failure Warning active. Unit in power failure; display operating on battery power. Check unit plug, unit circuit breaker in the ON position, and supply voltage.</p> <p>Ticker: Power Failure</p> |
| Power Failure Warning Recovered | None | Yellow | None | None | <p>Header: Power Failure Warning Recovered</p> <p>Details: Power has been restored. Select check box and press Acknowledge to clear this notification.</p> <p>Ticker: None</p> |
| Stage 1 Failure Warning | High | Red | Yes | Yes | <p>Header: Stage 1 Failure Warning</p> <p>Details: Stage 1 Failure Warning active. System may be unable to maintain cabinet setpoint due to loss of communication, or compressor or inverter failure. Contact customer service. [Error code:XX.]</p> <p>Ticker: Stage 1 Failure</p> |
| Stage 1 Failure Warning Recovered | None | Yellow | None | None | <p>Header: Stage 1 Failure Warning Recovered</p> <p>Details: Stage 1 Failure Warning has recovered. Select check box and press Acknowledge to clear this notification.</p> <p>Ticker: None</p> |
| Stage 2 Failure Warning | High | Red | Yes | Yes | <p>Header: Stage 2 Failure Warning</p> <p>Details: Stage 2 Failure Warning active. System may be unable to maintain cabinet setpoint due to loss of communication, or compressor or inverter failure. Contact customer service. [Error code:XX.]</p> <p>Ticker: Stage 2 Failure</p> |
| Stage 2 Failure Warning Recovered | None | Yellow | None | None | <p>Header: Stage 2 Failure Warning Recovered</p> <p>Details: Stage 2 Failure Warning has recovered. Select check box and press Acknowledge to clear this notification.</p> <p>Ticker: None</p> |
| System Battery Disconnected Warning | High | Red | Yes | Yes | <p>Header: System Battery Disconnected Warning</p> <p>Details: System Battery Disconnected Warning active. Unit will not be able to warm the user during power failure. May take up to 4 hrs. to clear even with a new battery.</p> <p>Ticker: System Battery Disconnected</p> |

| Warning/ Caution Summary | | | | | |
|---|-------------|--------------|---------------|------------------|---|
| Warning/ Caution | Tone | Heart | Remote | Ring-back | Message Details |
| System Battery Disconnected Warning Recovered | None | Yellow | None | None | <p>Header: System Battery Disconnected Warning Recovered</p> <p>Details: System Battery Disconnected Warning has recovered. System battery reconnected. Select check box and press Acknowledge to clear this notification.</p> <p>Ticker: None</p> |
| System Battery Low Caution | None | Yellow | None | None | <p>Header: System Battery Low Caution</p> <p>Details: System battery is low. Recommend replacing battery. Contact customer service for replacement battery. May take up to 4 hrs. to clear even with a new battery.</p> <p>Ticker: None</p> |
| System Battery PM Expiry Caution | None | Yellow | None | None | <p>Header: System Battery PM Expiry Caution</p> <p>Details: Recommend replacing the system battery. Reset battery expiration time using the Status screen to clear this notification.</p> <p>Ticker: None</p> |
| TC1-2,5-9 Failure Caution | None | Yellow | None | None | <p>Header: TCXX Failure Caution</p> <p>Details: Thermocouple TCXX has malfunctioned. Contact customer service.</p> <p>Ticker: None</p> |
| UI Lost Communication Warning | High | Red | Yes | Yes | <p>Header: UI Lost Communication Warning</p> <p>Details: UI Lost Communication Warning active. A UI communication error has occurred. Contact customer service.</p> <p>[Optional event details]</p> <p>Ticker: UI Lost Communication.</p> |
| UI Lost Communication Warning Recovered | None | Yellow | None | None | <p>Header: UI Lost Communication Warning Recovered</p> <p>Details: A UI communication error has recovered. Select check box and press Acknowledge to clear this notification.</p> <p>Ticker: None</p> |

| Warning/ Caution Summary | | | | | |
|---------------------------------|-------------|--------------|---------------|------------------|---|
| Warning/ Caution | Tone | Heart | Remote | Ring-back | Message Details |
| Unacknowledged Messages Caution | None | Yellow | None | None | <p>Header: Unacknowledged Messages [Warnings/Cautions]</p> <p>Details: There are [xx] additional unacknowledged messages regarding [message type] since [date and time]. See event log for details. Select check box and press Acknowledge to clear this notification.</p> <p>Ticker: None</p> |
| Wrong Power Warning | High | Yellow | Yes | Yes | <p>Header: Wrong Power Warning</p> <p>Details: Wrong power Warning active. The unit has detected that the wrong power is connected. Verify the proper voltage.</p> <p>Ticker: Wrong Power</p> |

Note: *Ring-back refers to the audible warning activating again after the user presses the Snooze button. The time can be set in the 'Snooze Timeout' option in the warning Settings screen.

Appendix B: Event Log Detail

| Event Log Entry Detail | |
|-------------------------------|--|
| Item | Message |
| Automatic Firmware Update | <p>Header: Automatic Firmware Update</p> <p>Role: N/A</p> <p>Mode: N/A</p> <p>Detail: Parameter table automatically updated.</p> |
| BUS Battery Reset | <p>Header: BUS Battery Reset</p> <p>Role: Logged in user or anonymous in full access mode.</p> <p>Mode: Full access or secure mode.</p> <p>Detail: BUS battery replacement schedule has been reset.</p> |
| BUS Injection | <p>Header: BUS Injection [Active, Inactive]</p> <p>Role: N/A.</p> <p>Mode: N/A.</p> <p>Detail: BUS tank solenoid has changed state to [active, inactive].</p> |
| BUS Pressure Switch | <p>Header: BUS Pressure Switch [Active, Inactive].</p> <p>Role: N/A.</p> <p>Mode: N/A.</p> <p>Detail: BUS pressure switch has changed state to [active, inactive].</p> |
| Caution | <p>Header: [Caution Header]</p> <p>Role: N/A.</p> <p>Mode: N/A.</p> <p>Detail: [Caution Details]</p> |
| Caution Recovered | <p>Header: [Caution Header] recovered</p> <p>Role: N/A.</p> <p>Mode: N/A.</p> <p>Detail: [Caution Header] has recovered. [Optional details]</p> |
| Configuration Import / Export | <p>Header: Configuration [Import, Export] Initiated</p> <p>Role: Logged in user for secure mode. Anonymous for full access mode.</p> <p>Mode: Full access or secure mode.</p> <p>Detail: Following item(s) has been [imported, exported] to USB: User database, System and User Interface settings, Temperature and Event history.</p> |

| Event Log Entry Detail | |
|---|---|
| Item | Message |
| Configuration Import Duplicate User IDs | <p>Header: Configuration Import Duplicate User IDs</p> <p>Role: Logged in user for secure mode. Anonymous for full access mode.</p> <p>Mode: Full access or secure mode.</p> <p>Detail: The below users were not imported due to collision with existing User IDs: [List of user names].</p> |
| Control Setting Change | <p>Header: Control Setting Change.</p> <p>Role: Logged in user for secure mode. Anonymous for full access mode</p> <p>Mode: Full access or secure mode.</p> <p>Detail: The following control setting(s) have been changed: Setting AA From: XX To: YY.</p> |
| Door Close | <p>Header: Door Close</p> <p>Role: N/A</p> <p>Mode: N/A</p> <p>Detail: Door closed after HH:MM:SS.</p> |
| Door History Reset | <p>Header: Door History Reset</p> <p>Role: Logged in user for secure mode. Anonymous for full access mode.</p> <p>Mode: Full access or secure mode.</p> <p>Detail: Door history has been reset.</p> |
| Door Open | <p>Header: Door Open</p> <p>Role: N/A</p> <p>Mode: N/A</p> <p>Detail: Door opened.</p> |
| Export | <p>Header: Export</p> <p>Role: Logged in user for secure mode. Anonymous for full access mode.</p> <p>Mode: Full access or secure mode.</p> <p>Detail: Temperature, temperature and event log or PDF report] have/has been exported. Date Range of export is from X to Y. File format exported is [PDF, CSV, or PUC].</p> |
| Export Cancelled | <p>Header: Export Cancelled</p> <p>Role: Logged in user for secure mode. Anonymous for full access mode.</p> <p>Mode: Full access or secure mode.</p> <p>Detail: Export was cancelled by the user.</p> |
| Firmware Build Compatible | <p>Header: Firmware Build Compatible</p> <p>Role: N/A</p> <p>Mode: N/A</p> <p>Detail: All the firmware components updated successfully and are adhering to current build XX.XX</p> |

| Event Log Entry Detail | |
|-------------------------------|---|
| Item | Message |
| Flash Settings | <p>Header: Flash Settings</p> <p>Role: N/A</p> <p>Mode: N/A</p> <p>Detail: [List of current flash settings]</p> |
| HID Access | <p>Header: HID Access</p> <p>Role: N/A</p> <p>Mode: Secure mode and HID option installed.</p> <p>Detail: User XXX scanned and door unlocked.</p> |
| High Temperature Warning Test | <p>Header: High Temperature Warning Test</p> <p>Role: N/A</p> <p>Mode: N/A</p> <p>Detail: High temperature warning test [started, completed].</p> |
| Invalid HID | <p>Header: Invalid HID</p> <p>Role: N/A</p> <p>Mode: Secure mode only.</p> <p>Detail: An HID card XXX was scanned that is not in the database.</p> |
| Main Power On Reset | <p>Header: Main Power On Reset</p> <p>Role: N/A</p> <p>Mode: N/A</p> <p>Detail: The main system has reset, RSR=[X].</p> |
| Memory Error | <p>Header: Memory Error ([Flash, RAM])</p> <p>Role: N/A</p> <p>Mode: N/A</p> <p>Detail: The system has detected an error in the [flash, RAM] memory. Settings will be recovered from redundant storage.</p> |
| Password Expired | <p>Header: Password Expired</p> <p>Role: N/A</p> <p>Mode: Secure mode only.</p> <p>Detail: Password for user XXX has expired.</p> |
| Password Reset | <p>Header: Password Reset</p> <p>Role: N/A</p> <p>Mode: Secure mode only.</p> <p>Detail: Password reset has been requested for user XXX. A temporary PIN will be active for 24 hours.</p> |

| Event Log Entry Detail | |
|-------------------------------|--|
| Item | Message |
| Password Updated | <p>Header: Password Updated</p> <p>Role: N/A</p> <p>Mode: Secure mode only.</p> <p>Detail: The password for user XXX has been updated.</p> |
| Power Brief Interruption | <p>Header: Power Brief Interruption [Detected, Recovered]</p> <p>Role: N/A</p> <p>Mode: N/A</p> <p>Detail: A brief interruption of power has been [detected, recovered]. [Error code: X]</p> |
| Reset to Factory Defaults | <p>Header: Reset to Factory Defaults</p> <p>Role: Logged in user or anonymous in full access mode.</p> <p>Mode: Full access or secure mode.</p> <p>Detail: The system has been restored to factory defaults.</p> |
| System Battery Reset | <p>Header: System battery Reset</p> <p>Role: Logged in user or anonymous in full access mode.</p> <p>Mode: Full access or secure mode.</p> <p>Detail: System battery replacement schedule has been reset.</p> |
| Temperature Excursion Reset | <p>Header: Temperature Excursion Reset</p> <p>Role: Logged in user for secure mode. Anonymous for full access mode.</p> <p>Mode: Full access or secure mode.</p> <p>Detail: Temperature excursion history has been reset to the current cabinet temperature.</p> |
| Thread Lock | <p>Header: Thread Lock</p> <p>Role: N/A</p> <p>Mode: N/A</p> <p>Detail: Thread [name of thread] locked. UI will reset.</p> |
| UI Power On Reset | <p>Header: UI Power On Reset</p> <p>Role: N/A</p> <p>Mode: N/A</p> <p>Detail: The UI system has reset.</p> |
| UI Switch Active | <p>Header: UI Switch Active</p> <p>Role: Logged in user for secure mode. Anonymous for full access mode.</p> <p>Mode: Full access or secure mode.</p> <p>Detail: System has been reactivated.</p> |

| Event Log Entry Detail | |
|--------------------------------------|---|
| Item | Message |
| UI Switch Standby | <p>Header: UI Switch Standby</p> <p>Role: Logged in user for secure mode. Anonymous for full access mode.</p> <p>Mode: Full access or secure mode.</p> <p>Detail: System has been placed into standby.</p> |
| Unit Information | <p>Header: Unit Information</p> <p>Role: N/A</p> <p>Mode: N/A</p> <p>Detail: [List of current unit configuration values]</p> |
| Unit Passcode Cleared | <p>Header: Unit Passcode Cleared</p> <p>Role: N/A</p> <p>Mode: Full access mode only.</p> <p>Detail: Unit passcode has been cleared.</p> |
| Unit Passcode Set | <p>Header: Unit Passcode Set</p> <p>Role: N/A</p> <p>Mode: Full access mode only.</p> <p>Detail: Unit passcode has been Set.</p> |
| User Account Activated / Deactivated | <p>Header: User Account [Activated, Deactivated]</p> <p>Role: Admin</p> <p>Mode: Secure mode only.</p> <p>Detail: User XXX account has been successfully [activated, deactivated].</p> |
| User Account Deactivated by System | <p>Header: User Account Deactivated by System</p> <p>Role: System</p> <p>Mode: Secure mode only.</p> <p>Detail: The user account for XXX has been deactivated due to repeated login failures. An administrator is required to reactivate the account.</p> |
| User Acknowledge | <p>Header: User Acknowledge</p> <p>Role: Logged in user or blank if full access.</p> <p>Mode: Full access or secure mode.</p> <p>Detail: User acknowledged X events.</p> |
| User Added To Database | <p>Header: User Added To Database</p> <p>Role: N/A</p> <p>Mode: Secure mode only.</p> <p>Detail: User XXX has been added to user database.</p> |

| Event Log Entry Detail | |
|-------------------------------|---|
| Item | Message |
| User Details Updated | <p>Header: User Details Updated</p> <p>Role: N/A</p> <p>Mode: Secure mode only.</p> <p>Detail: User XXX details successfully updated.</p> |
| User Interface Setting Change | <p>Header: User Interface Setting Change</p> <p>Role: Logged in user for secure mode. Anonymous for full access mode</p> <p>Mode: Full access or secure mode.</p> <p>Detail: The following user interface setting(s) have been changed: Setting AA From: XX To: YY.</p> |
| User Login | <p>Header: User Login</p> <p>Role: N/A</p> <p>Mode: Secure mode only except for service login.</p> <p>Detail: User XXX logged in.</p> |
| User Logout | <p>Header: User Logout</p> <p>Role: N/A</p> <p>Mode: Secure mode only except for service login.</p> <p>Detail: User XXX logged out.</p> |
| Warning | <p>Header: [Warning Header]</p> <p>Role: N/A</p> <p>Mode: Full access or secure mode.</p> <p>Detail: [Warning Details]</p> |
| Warning Automatically Snoozed | <p>Header: Warning Automatically Snoozed</p> <p>Role: N/A</p> <p>Mode: Full access or secure mode.</p> <p>Detail: A [15 minute, 30 minute, 1 hour] automatic snooze has occurred.</p> |
| Warning Recovered | <p>Header: [Warning Header] Recovered</p> <p>Role: N/A</p> <p>Mode: Full access or secure mode.</p> <p>Detail: [Warning Recovered Details]</p> |

Appendix C: City Time Zone

Time specified in the time zone indicates the difference with UTC.

| Time Zone | City |
|-------------------|-------------|
| (Africa +00:00) | EIAaiun |
| | Freetown |
| | Lome |
| | Abidjan |
| | Accra |
| | Bamako |
| | Banjul |
| | Bissau |
| | Casablanca |
| | Conakry |
| | Dakar |
| | Monrovia |
| | Nouakchott |
| | Ouagadougou |
| (Africa +01:00) | Algiers |
| | Bangui |
| | Brazzaville |
| | Ceuta |
| | Douala |
| | Kinshasa |
| | Lagos |
| | Libreville |
| | Luanda |
| | Malabo |
| | Ndjamena |
| | Niamey |
| | Porto-Novo |
| | Sao_Tome |
| Tunis | |

| Time Zone | City |
|--------------------|--------------|
| (Africa +02:00) | Gaborone |
| | Harare |
| | Johannesburg |
| | Khartoum |
| | Kigali |
| | Lubumbashi |
| | Lusaka |
| | Maputo |
| | Blantyre |
| | Bujumbura |
| | Cairo |
| | Maseru |
| | Mbabane |
| | Tripoli |
| Windhoek | |
| (Africa +03:00) | Juba |
| | Kampala |
| | AddisAbaba |
| | Asmara |
| | DaresSalaam |
| | Djibouti |
| | Mogadishu |
| Nairobi | |
| (America +00:00) | Danmarkshavn |
| (America -01:00) | Scoresbysund |

| Time Zone | City |
|--------------------|--------------|
| (America -02:00) | Noronha |
| | |
| (America -03:00) | Araguaina |
| | Bahia |
| | Belem |
| | Cayenne |
| | Fortaleza |
| | Godthab |
| | Maceio |
| | Miquelon |
| | Montevideo |
| | Paramaribo |
| | Recife |
| | Santarem |
| SaoPaulo | |
| | |
| (America -03:30) | StJohns |
| | |
| | Anguilla |
| (America -04:00) | Antigua |
| | Aruba |
| | Asuncion |
| | Barbados |
| | Blanc-Sablon |
| | BoaVista |
| | CampoGrande |
| | Caracas |
| | Cuiaba |
| | Curacao |
| | Dominica |
| | GlanceBay |
| | GooseBay |
| | GrandTurk |

| Time Zone | City |
|--------------------|--------------|
| (America -04:00) | Grenada |
| | Guadeloupe |
| | Guyana |
| | Halifax |
| | Kralendijk |
| | LaPaz |
| | LowerPrinces |
| | Manaus |
| | Marigot |
| | Martinique |
| | Moncton |
| | Montserrat |
| | PortofSpain |
| | PortoVelho |
| | PuertoRico |
| | Santiago |
| | SantoDomingo |
| | StBarthelemy |
| | StKitts |
| StLucia | |
| StThomas | |
| StVincent | |
| Thule | |
| Tortola | |
| | |
| (America -05:00) | Atikokan |
| | Bogota |
| | Cancun |
| | Cayman |
| | Detroit |
| | Eirunepe |
| | Guayaquil |
| | Havana |

| Time Zone | City |
|-----------------------|----------------|
| (America -05:00) | Iqaluit |
| | Jamaica |
| | Lima |
| | Nassau |
| | NewYork |
| | Nipigon |
| | Panama |
| | Pangnirtung |
| | Port-au-Prince |
| | RioBranco |
| | ThunderBay |
| | Toronto |
| | |
| (America -06:00) | BahiaBanderas |
| | Belize |
| | Chicago |
| | CostaRica |
| | EISalvador |
| | Guatemala |
| | Managua |
| | Matamoros |
| | Menominee |
| | Merida |
| | MexicoCity |
| | Monterrey |
| | RainyRiver |
| | RankinInlet |
| | Regina |
| | Resolute |
| | SwiftCurrent |
| Tegucigalpa | |
| Winnipeg | |
| | |
| (Antarctica +06:00) | Vostok |
| (Antarctica +07:00) | Davis |
| (Antarctica +10:00) | DumontDUrville |
| (Antarctica +11:00) | Casey |
| (Antarctica +12:00) | McMurdo |
| (Antarctica +06:00) | Vostok |

| Time Zone | City |
|-----------------------|--------------|
| (America -07:00) | Boise |
| | CambridgeBay |
| | Chihuahua |
| | Creston |
| | DawsonCreek |
| | Denver |
| | Edmonton |
| | FortNelson |
| | Hermosillo |
| | Inuvik |
| | Mazatlan |
| Ojinaga | |
| Phoenix | |
| Yellowknife | |
| | |
| (America -08:00) | Dawson |
| | LosAngeles |
| | Tijuana |
| | Vancouver |
| Whitehorse | |
| | |
| (America -09:00) | Anchorage |
| | Juneau |
| | Metlakatla |
| | Nome |
| | Sitka |
| Yakutat | |
| | |
| (America -10:00) | Adak |
| (Antarctica +00:00) | Troll |
| (Antarctica +03:00) | Syowa |
| (Antarctica +05:00) | Mawson |
| (Asia +04:00) | Baku |
| | Dubai |
| | Muscat |
| | Tbilisi |
| | Yerevan |
| | |
| (Asia +04:30) | Kabul |

| Time Zone | City |
|-----------------------|--------------|
| (Antarctica -03:00) | Palmer |
| | Rothera |
| (Arctic +01:00) | Longyearbyen |
| (Asia +02:00) | Amman |
| | Beirut |
| | Damascus |
| | Famagusta |
| | Gaza |
| | Hebron |
| | Jerusalem |

| | |
|-----------------|--------------|
| (Asia +03:00) | Aden |
| | Baghdad |
| | Bahrain |
| | Kuwait |
| | Qatar |
| | Riyadh |
| (Asia +03:30) | Tehran |
| (Asia +06:30) | Yangon |
| (Asia +07:00) | Bangkok |
| | Barnaul |
| | HoChiMinh |
| | Hovd |
| | Jakarta |
| | Krasnoyarsk |
| | Novokuznetsk |
| | Novosibirsk |
| | PhnomPenh |
| | Pontianak |
| | Tomsk |
| | Vientiane |

| Time Zone | City |
|-----------------|---------------|
| (Asia +05:00) | Aqtau |
| | Aqtobe |
| | Ashgabat |
| | Dushanbe |
| | Karachi |
| | Oral |
| | Samarkand |
| | Tashkent |
| (Asia +05:30) | Yekaterinburg |
| | Colombo |
| | Kolkata |

| | |
|-----------------|---------------|
| (Asia +05:45) | Kathmandu |
| (Asia +06:00) | Almaty |
| | Dhaka |
| | Omsk |
| | Qyzylorda |
| | Thimphu |
| | Urumqi |
| (Asia +09:00) | Chita |
| | Dili |
| | Jayapura |
| | Khandyga |
| | Seoul |
| | Yakutsk |
| (Asia +10:00) | Ust-Nera |
| | Vladivostok |
| (Asia +11:00) | Magadan |
| | Sakhalin |
| | Srednekolymsk |

| Time Zone | City |
|----------------------|-------------|
| (Asia +08:00) | Brunei |
| | Choibalsan |
| | HongKong |
| | Irkutsk |
| | KualaLumpur |
| | Kuching |
| | Macau |
| | Makassar |
| | Manila |
| | Shanghai |
| | Singapore |
| | Taipei |
| | Ulaanbaatar |
| (Asia +08:30) | Pyongyang |
| (Australia +08:45) | Eucla |
| (Australia +09:30) | Adelaide |
| | BrokenHill |
| | Darwin |
| (Australia +10:00) | Brisbane |
| | Currie |
| | Hobart |
| | Lindeman |
| | Melbourne |
| Sydney | |
| (Europe +00:00) | Dublin |
| | Guernsey |
| | IsleofMan |
| | Jersey |
| | Lisbon |
| | London |
| (Europe +01:00) | Amsterdam |
| | Andorra |
| | Belgrade |
| | Berlin |
| | Bratislava |
| | Brussels |
| | Budapest |
| | Busingen |
| | Copenhagen |
| | Gibraltar |
| | Ljubljana |
| | Luxembourg |
| | Madrid |

| Time Zone | City |
|----------------------|--------------|
| (Asia +12:00) | Anadyr |
| | Kamchatka |
| (Atlantic +00:00) | Canary |
| | Faroe |
| | Madeira |
| | Reykjavik |
| StHelena | |
| (Atlantic -01:00) | Azores |
| | CapeVerde |
| (Atlantic -02:00) | SouthGeorgia |
| (Atlantic -03:00) | Stanley |
| (Atlantic -04:00) | Bermuda |
| (Australia +08:00) | Perth |
| (Europe +01:00) | Malta |
| | Monaco |
| | Oslo |
| | Paris |
| | Podgorica |
| | Prague |
| | Rome |
| | SanMarino |
| | Sarajevo |
| | Skopje |
| | Stockholm |
| | Tirane |
| | Vaduz |
| | Vatican |
| | Vienna |
| | Warsaw |
| Zagreb | |
| Zurich | |
| (Europe +02:00) | Athens |
| | Bucharest |
| | Chisinau |
| | Helsinki |
| | Kaliningrad |
| | Kiev |
| | Mariehamn |
| | Riga |
| | Sofia |
| | Tallinn |
| | Uzhgorod |
| Vilnius | |
| Zaporozhye | |

| Time Zone | City |
|-------------------|--------------|
| | |
| (Europe +03:00) | Istanbul |
| | Kirov |
| | Minsk |
| | Moscow |
| | Simferopol |
| | Volgograd |
| | |
| (Europe +04:00) | Astrakhan |
| | Samara |
| | Ulyanovsk |
| | |
| (Indian +03:00) | Antananarivo |
| | Comoro |
| | Mayotte |
| | |
| (Indian +04:00) | Mahe |
| | Mauritius |
| | Reunion |

| | |
|--------------------|-------------|
| (Indian +05:00) | Kerguelen |
| | Maldives |
| | |
| (Indian +06:00) | Chagos |
| (Indian +06:30) | Cocos |
| (Indian +07:00) | Christmas |
| (Pacific +09:00) | Palau |
| | |
| (Pacific +10:00) | Chuuk |
| | Guam |
| | PortMoresby |
| | Saipan |
| | |
| (Pacific -10:00) | Honolulu |
| | Johnston |
| | Rarotonga |
| | Tahiti |
| | |
| (Pacific -11:00) | Midway |
| | Niue |
| | PagoPago |

| Time Zone | City |
|--------------------|--------------|
| | |
| (Pacific +11:00) | Bougainville |
| | Efate |
| | Guadalcanal |
| | Kosrae |
| | Norfolk |
| | Noumea |
| | Pohnpei |
| | |
| (Pacific +12:00) | Auckland |
| | Fiji |
| | Funafuti |
| | Kwajalein |
| | Majuro |
| | Nauru |
| | Tarawa |
| | Wake |
| Wallis | |

| | |
|--------------------|------------|
| (Pacific +12:45) | Chatham |
| | |
| (Pacific +13:00) | Apia |
| | Enderbury |
| | Fakaofu |
| | Tongatapu |
| | |
| (Pacific +14:00) | Kiritimati |
| (Pacific -06:00) | Easter |
| | Galapagos |
| | |
| (Pacific -08:00) | Pitcairn |
| (Pacific -09:00) | Gambier |
| (Pacific -09:30) | Marquesas |

Appendix D: Modbus ASCII (Read Only) Parameter Table

| | |
|--------------|---------------------|
| Protocol | Modbus ASCII |
| Baud Rate | 2400bps to 57.6Kbps |
| Data Bits | 7 |
| Stop Bits | 1 |
| Parity | Even |
| Flow Control | None |
| Address | 0 to 255 |

| No | Parameter | Function Code | Address in Hex | Size | Modbus Command | Relay Enclosure Response | Data | Data Type | Remarks |
|----|---------------------------|---------------|----------------|------|---|---|------------|-----------|--|
| 1 | Cabinet Setpoint (C) | 0x03 | 530 | 2 | 3A 31 39 30 33 30 35 33 30 30 30 30 32 41 44 0D 0A | 3A 31 39 30 33 30 34 46 46 46 46 46 43 45 30 30 32 0D 0A | 0xFFFFFCE0 | int | Convert the data value into signed 2's complement and divide by 10, which gives the setpoint. Ex: Signed 2's complement of the 0xFFFFFCE0 is equal to 800. -800/10= -80. Meaning setpoint is -80C. |
| 2 | Warm warning Setpoint (C) | 0x03 | 538 | 2 | 3A 31 39 30 33 30 35 33 38 30 30 30 32 41 35 0D 0A | 3A 31 39 30 33 30 34 46 46 46 46 46 44 34 34 39 44 0D 0A | 0xFFFFFD44 | int | Convert the data value into signed 2's complement and divide with 10, which gives the setpoint. Ex: Signed 2's complement of the 0xFFFFFD44 is equal to -700. -700/10= -70. Meaning WA setpoint is -70 C. |
| 3 | Cold warning Setpoint (C) | 0x03 | 53C | 2 | 3A 31 39 30 33 30 35 33 43 30 30 30 32 41 31 0D 0A | 3A 31 39 30 33 30 34 46 46 46 46 46 43 37 43 36 36 0D 0A | 0xFFFFFC7C | int | Convert the data value into signed 2's complement and divide with 10, which gives the setpoint. Ex: Signed 2's complement of the 0xFFFFFC7C is equal to -900. -900/10=-90. Meaning CA setpoint is -90C. |

| No | Parameter | Function Code | Address in Hex | Size | Modbus Command | Relay Enclosure Response | Data | Data Type | Remarks |
|----|-------------------------------------|---------------|----------------|------|---|--|------------|-----------|---|
| 4 | System Bill of Material Part Number | 0x03 | 570 | 2 | 3A 31 39 30 33 30 35 37 30 30 30 30 41 36 35 0D 0A | 3A 31 39 30 33 32 34 33 31 33 35 33 35 34 34 35 32 33 30 34 31 33 30 33 31 35 32 32 30 32 30 32 30 32 30 32 30 32 30 32 30 32 30 32 30 32 30 32 30 32 30 32 30 32 30 32 30 32 30 44 30 0D 0A | 155DR0A01R | string | All the remaining are spaces. |
| 5 | Product ID | 0x03 | 598 | 2 | 3A 31 39 30 33 30 35 39 38 30 30 30 32 34 35 0D 0A | 3A 31 39 30 33 30 34 30 30 30 31 45 32 34 30 42 39 0D 0A | 0x0001E240 | uint | 123456 would be encoded as 0x01E240. |
| 6 | Control Model | 0x03 | 59C | 1 | 3A 31 39 30 33 30 35 39 43 30 30 30 31 34 32 0D 0A | 3A 31 39 30 33 30 32 30 34 44 45 0D 0A | 0x04 | uchar | Note: bits b4:b1 0000: PEEK Production Code (CNTRL 0) 0002: Variable Speed Compressor (CNTRL 2) 0003: Single Speed and Cascade System (CNTRL 3) 0004: Single Speed and Single Stage System (CNTRL 4) 0005: Single Speed and Cascade System (CNTRL 5). |
| 7 | Size | 0x03 | 59D | 1 | 3A 31 39 30 33 30 35 39 44 30 30 30 31 34 31 0D 0A | 3A 31 39 30 33 30 32 30 32 45 30 0D 0A | 0x02 | uchar | 5 units sizes 0 - 300, 1- 400, 2 - 500, 3 - 600, 4 - 700. |

| No | Parameter | Function Code | Address in Hex | Size | Modbus Command | Relay Enclosure Response | Data | Data Type | Remarks |
|----|-----------|---------------|----------------|------|---|---|------------|-----------|---|
| 8 | TC1 | 0x03 | 4C8 | 2 | 3A 31 39 30 33 30 34 43 38 30 30 30 32 31 36 0D 0A | 3A 31 39 30 33 30 34 34 31 42 34 33 31 39 31 32 31 0D 0A | 0x41B83191 | float | Convert the Float to decimal with below steps: 1.Open the link https://www.h-schmidt.net/FloatConverter/IEEE754.html 2.Paste the data in “Hexadecimal Representation” and press Enter. 3.The temperature value is shown in “Decimal representation.” |
| 9 | TC2 | 0x03 | 4CC | 2 | 3A 31 39 30 33 30 34 43 43 30 30 30 32 31 32 0D 0A | 3A 31 39 30 33 30 34 34 31 42 42 34 34 45 34 42 34 0D 0A | 0x41BB48E4 | float | Convert the Float to decimal with below steps: 1.Open the link https://www.h-schmidt.net/FloatConverter/IEEE754.html 2.Paste the data in “Hexadecimal Representation” and press Enter. 3.The temperature value is shown in “Decimal representation.” |
| 10 | TC3 | 0x03 | 4D0 | 2 | 3A 31 39 30 33 30 34 44 30 30 30 30 32 30 45 0D 0A | 3A 31 39 30 33 30 34 34 31 42 42 30 43 41 43 32 34 0D 0A | 0x41BB0CAC | float | Convert the Float to decimal with below steps: 1.Open the link https://www.h-schmidt.net/FloatConverter/IEEE754.html 2.Paste the data in “Hexadecimal Representation” and press Enter. 3.The temperature value is shown in “Decimal representation.” |

| No | Parameter | Function Code | Address in Hex | Size | Modbus Command | Relay Enclosure Response | Data | Data Type | Remarks |
|----|-----------|---------------|----------------|------|---|---|------------|-----------|---|
| 11 | TC4 | 0x03 | 4D4 | 2 | 3A 31 39 30 33 30 34 44 34 30 30 30 32 30 41 0D 0A | 3A 31 39 30 33 30 34 34 31 45 35 34 31 36 45 43 37 0D 0A | 0x41E5816E | float | Convert the Float to decimal with below steps: 1.Open the link https://www.h-schmidt.net/FloatConverter/IEEE754.html 2.Paste the data in “Hexadecimal Representation” and press Enter. 3.The temperature value is shown in “Decimal representation.” |
| 12 | TC5 | 0x03 | 4D8 | 2 | 3A 31 39 30 33 30 34 44 38 30 30 30 32 30 36 0D 0A | 3A 31 39 30 33 30 34 43 32 46 45 30 30 30 30 31 43 0D 0A | 0xC2FE0000 | float | Convert the Float to decimal with below steps: 1.Open the link https://www.h-schmidt.net/FloatConverter/IEEE754.html 2.Paste the data in “Hexadecimal Representation” and press Enter. 3.The temperature value is shown in “Decimal representation.” |
| 13 | TC6 | 0x03 | 4DC | 2 | 3A 31 39 30 33 30 34 44 43 30 30 30 32 30 32 0D 0A | 3A 31 39 30 33 30 34 43 32 46 45 30 30 30 30 31 43 0D 0A | 0xC2FE0000 | float | Convert the Float to decimal with below steps: 1.Open the link https://www.h-schmidt.net/FloatConverter/IEEE754.html 2.Paste the data in “Hexadecimal Representation” and press Enter. 3.The temperature value is shown in “Decimal representation.” |

| No | Parameter | Function Code | Address in Hex | Size | Modbus Command | Relay Enclosure Response | Data | Data Type | Remarks |
|----|-----------|---------------|----------------|------|---|---|------------|-----------|---|
| 14 | TC7 | 0x03 | 4E0 | 2 | 3A 31 39 30 33 30 34 45 30 30 30 30 32 46 45 0D 0A | 3A 31 39 30 33 30 34 43 32 46 45 30 30 30 30 31 43 0D 0A | 0xC2FE0000 | float | Convert the Float to decimal with below steps: 1.Open the link https://www.h-schmidt.net/FloatConverter/IEEE754.html 2.Paste the data in “Hexadecimal Representation” and press Enter. 3.The temperature value is shown in “Decimal representation.” |
| 15 | TC8 | 0x03 | 4E4 | 2 | 3A 31 39 30 33 30 34 45 34 30 30 30 32 46 41 0D 0A | 3A 31 39 30 33 30 34 34 31 42 43 43 44 39 46 37 33 0D 0A | 0x41BCCD9F | float | Convert the Float to decimal with below steps: 1.Open the link https://www.h-schmidt.net/FloatConverter/IEEE754.html 2.Paste the data in “Hexadecimal Representation” and press Enter. 3.The temperature value is shown in “Decimal representation.” |
| 16 | TC9 | 0x03 | 4E8 | 2 | 3A 31 39 30 33 30 34 45 38 30 30 30 32 46 36 0D 0A | 3A 31 39 30 33 30 34 34 31 42 45 32 34 41 31 31 34 0D 0A | 0x41BE28A1 | float | Convert the Float to decimal with below steps. 1.Open the link https://www.h-schmidt.net/FloatConverter/IEEE754.html 2.Paste the data in “Hexadecimal Representation” and press Enter. 3.The temperature value is shown in “Decimal representation.” |

| No | Parameter | Function Code | Address in Hex | Size | Modbus Command | Relay Enclosure Response | Data | Data Type | Remarks |
|----|---------------------------------|---------------|----------------|------|---|---|------------|-----------|---|
| 17 | TC10 | 0x03 | 4EC | 2 | 3A 31 39 30 33 30 34 45 43 30 30 30 32 46 32 0D 0A | 3A 31 39 30 33 30 34 34 31 42 45 32 43 37 45 33 33 0D 0A | 0x41BE2C7E | float | Convert the Float to decimal with below steps. 1.Open the link https://www.h-schmidt.net/FloatConverter/IEEE754.html 2.Paste the data in “Hexadecimal Representation” and press Enter. 3.The temperature value is shown in “Decimal representation”. |
| 18 | Display Managed RTD Temperature | 0x03 | 500 | 2 | 3A 31 39 30 33 30 35 30 30 30 30 30 32 44 44 0D 0A | 3A 31 39 30 33 30 34 46 46 46 46 46 46 42 33 32 43 0D 0A | 0xFFFFFB2 | int | Convert the data value into signed 2's complement which gives the data. Ex: Signed 2's complement of the 0xFFFFFB2 is equal to -78. Meaning Display Managed RTD Temperature value is -78 °C. |

| No | Parameter | Function Code | Address in Hex | Size | Modbus Command | Relay Enclosure Response | Data | Data Type | Remarks |
|----|---------------|---------------|----------------|------|---|---|------------|-----------|---|
| 19 | Warnings | 0x03 | 514 | 2 | 3A 31 39 30 33 30 35 31 34 30 30 30 32 43 39 0D 0A | 3A 31 39 30 33 30 34 30 30 30 30 30 34 30 32 44 36 0D 0A | 0x00000402 | uint | 1 = Active / 0 = Inactive b19 BUS Battery Disconnection, b18 System Battery Disconnection, b17 Water temperature, b16 Wrong Power, b15 Refrigeration System Failure (TSX only), b14 Reserved for factory use only (Water Cooled pressure warning if applicable), b13 Unused, b12 Clean filter warning, b11 Reserved for factory use only, b10 Buck boost ineffective, b9 BUS battery low, b8 Setpoint attain timed out (every cycle), b7 Health of compressor (sump temperature), b6 - Extreme Ambient, b5 - System Battery Low, b4 - Control Probe Fail, b3 - Door Open, b2 - Cold warning, b0 - Power Failure warning. |
| 20 | System Status | 0x03 | 66F | 1 | 3A 31 39 30 33 30 36 36 46 30 30 30 31 36 45 0D 0A | 3A 31 39 30 33 30 32 32 38 42 41 0D 0A | 0x28 | uchar | b0 - Temperature pull down attained, b1 - Power failure, b2 - Main - UI comm failure, b3 - Service Mode Active, b4 - main shutdown, b5 - BOT status (set only after entry to BOT), b6 - unused, b7 - Bus comm failure. |

| No | Parameter | Function Code | Address in Hex | Size | Modbus Command | Relay Enclosure Response | Data | Data Type | Remarks |
|----|------------------------|---------------|----------------|------|---|---|------------|-----------|--|
| 21 | Relay Enclosure Status | 0x03 | 670 | 2 | 3A 31 39 30 33 30 36 37 30 30 30 30 32 36 43 0D 0A | 3A 31 39 30 33 30 34 30 30 30 35 30 30 30 30 44 37 0D 0A | 0x00050000 | uint | b0 - Bus Solenoid Injection, b1 - Bus Pressure switch, b2 - Reserved for factory use only, b3 - Line voltage circuit state change (normal, buck, boost), b4 - Compensated line voltage change, b5 - Reserved for factory use only, b6 - Short cycle active, b7 - 4-20mA digital to analog converter data corrupt, b8 - Next Power up state, b9 - Door1 Open, b10 - Door2 Open, b11 - Warm temperature warning test Active, b12 - Read Reset status register, b13 - Water cool system pressure sensor state (water cooled units only), b14 - 4-20mA digital to analog converter over-temperature fault, b15 - 4-20mA digital to analog converter over current of the integrated chip fault, b16 - Main memory corrupt, b17 - Back up memory corrupt. |
| 22 | Build Number | 0x03 | 524 | 2 | 3A 31 39 30 33 30 35 32 34 30 30 30 32 42 39 0D 0A | 3A 31 39 30 33 30 34 30 30 30 30 30 44 30 31 43 45 0D 0A | 0x00000D01 | uint | XX/XX Minor (numbers after decimal point)/ Major (numbers before decimal point). Ex: 1301 translates to Build number is 1.13. |

| No | Parameter | Function Code | Address in Hex | Size | Modbus Command | Relay Enclosure Response | Data | Data Type | Remarks |
|----|----------------------------|---------------|----------------|------|---|---|------------|-----------|---|
| 23 | Cabinet Calibration Offset | 0x03 | 534 | 2 | 3A 31 39 30 33 30 35 33 34 30 30 30 32 41 39 0D 0A | 3A 31 39 30 33 30 34 30 30 30 30 30 30 30 30 44 43 0D 0A | 0xFFFFFCE0 | int | Convert the data value into signed 2's complement and divide with 10, which gives the setpoint. Ex: Signed 2's complement of the 0xFFFFFCE0 is equal to -800. -800/10=-80. So the setpoint is -80C. |
| 24 | Line Voltage | 0x03 | 4F8 | 2 | 3A 31 39 30 33 30 34 46 38 30 30 30 32 45 36 0D 0A | 3A 31 39 30 33 30 34 30 30 30 30 30 30 45 34 46 34 0D 0A | 0x000000E4 | uint | Convert hex to decimal gives the voltage. Ex. Here 0xE4 is equal to 228 V. |

This page
is intentionally
left blank.

WEEE Compliance

WEEE Compliance. This product is required to comply with the European Union's Waste Electrical & Electronic Equipment (WEEE) Directive 2012/19/EU. It is marked with the following symbol. Thermo Fisher Scientific has contracted with one or more recycling/disposal companies in each EU Member State, and this product should be disposed of or recycled through them. Further information on our compliance with these Directives, the recyclers in your country, and information on Thermo Fisher Scientific products which may assist the detection of substances subject to applicable directives are available at www.thermofisher.com/WEEERoHS.

English



Conformité WEEE. Ce produit doit être conforme à la directive 2012/19/UE relative aux déchets d'équipements électriques et électroniques (DEEE) de l'Union européenne. Il est marqué du symbole suivant. Thermo Fisher Scientific a passé un contrat avec une ou plusieurs entreprises de recyclage/élimination dans chaque État membre de l'UE, et ce produit doit être éliminé ou recyclé par leur intermédiaire. De plus amples informations sur notre conformité à ces directives, les recycleurs dans votre pays et des informations sur les produits Thermo Fisher Scientific qui peuvent aider à la détection de substances soumises aux directives applicables sont disponibles sur www.thermofisher.com/WEEERoHS.

France





IF YOU NEED ASSISTANCE:

Thermo Fisher Scientific products are backed by a global technical support team ready to support your applications. We offer cold storage accessories, including remote warnings, temperature recorders, and validation services.

Visit www.thermofisher.com/support or call:

| Countries | Sales |
|-----------------------------|------------------------------|
| North America | +1 866 984 3766 |
| India toll free | 1800 22 8374 |
| India | +91 22 6716 2200 |
| China | +800 810 5118, +400 650 5118 |
| Japan | +81 3 5826 1616 |
| Australia | +61 39757 4300 |
| Austria | +43 1 801 40 0 |
| Belgium | +32 53 73 42 41 |
| France | +33 2 2803 2180 |
| Germany international | +49 6184 90 6000 |
| Germany national toll free | 0800 1 536 376 |
| Italy | +32 02 95059 552 |
| Netherlands | +31 76 579 55 55 |
| Nordic/Baltic/CIS countries | +358 9 329 10200 |
| Russia | +7 812 703 4215 |
| Spain/Portugal | +34 93 223 09 18 |
| Switzerland | +41 44 454 12 22 |
| UK/Ireland | +44 870 609 9203 |
| New Zealand | +64 9 980 6700 |
| Other Asian Countries | +852 2885 4613 |
| Countries not listed | +49 6184 90 6000 |

Thermo Fisher Scientific Inc.
275 Aiken Road
Asheville, NC 28804
United States

Find out more at thermofisher.com/support

