

# Operating Instructions

## CO<sub>2</sub> - Incubator BB 15

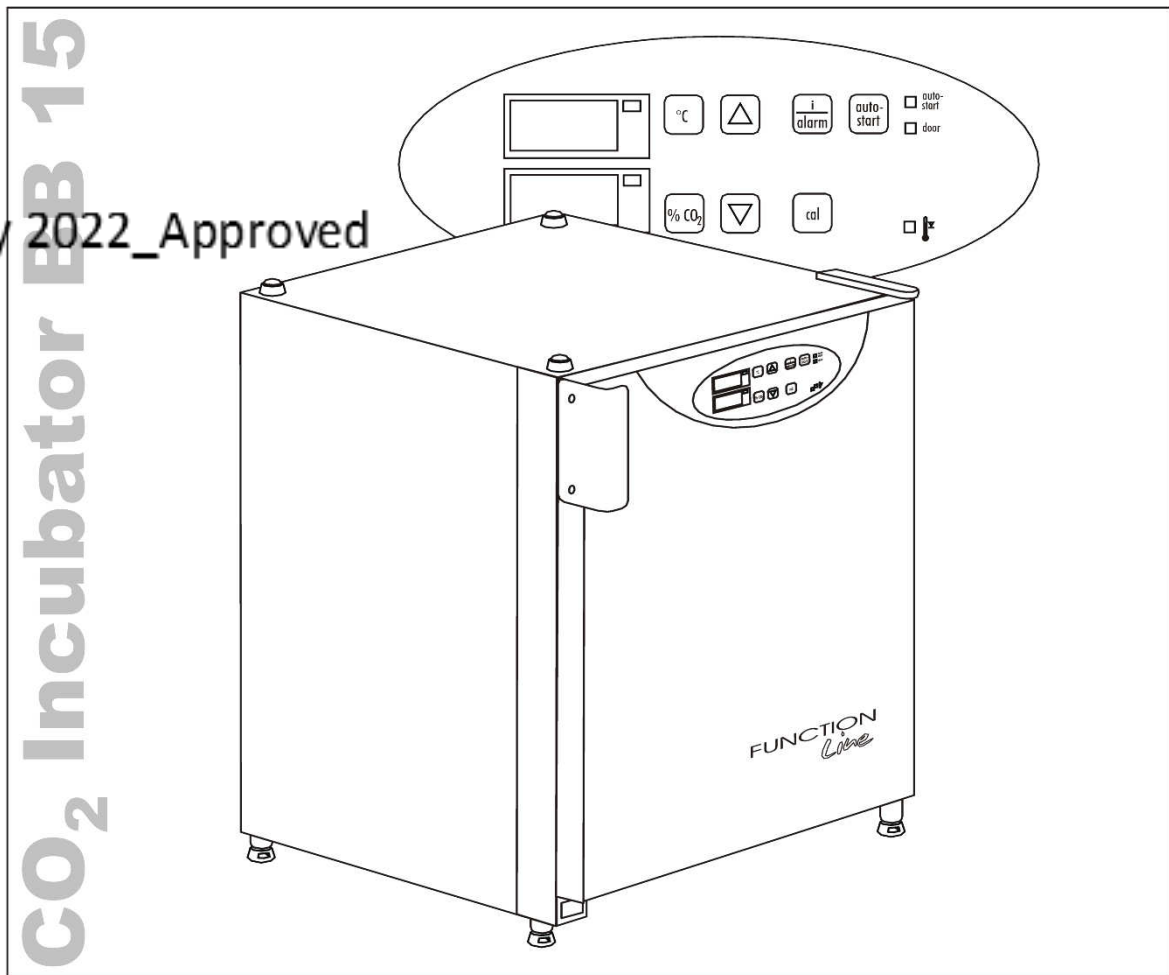

## **Copyright©2019**

These operating instructions are protected by copyright. Rights resulting thereof, particularly reprint, photomechanical or digital postprocessing or reproduction, even in part, are only allowed with the written consent of Thermo Electron LED GmbH.

This regulation does not apply to reproductions for in-plant use.

The contents of the operating instructions are subject to change without further notice. For translations into foreign languages, the German version of these operating instructions is binding.

## **Trademarks**

All trademarks mentioned in the operating instructions are the exclusive property of the respective manufacturers.

Thermo Electron LED GmbH  
Robert-Bosch-Straße 1  
D - 63505 Langenselbold  
Germany

## Contents

<b>1. General notes .....</b>	<b>6</b>
1.1 General safety instructions.....	7
1.2 Warranty.....	7
1.3 Explanation of symbols .....	8
1.3.1 Symbols used in the operating instructions .....	8
1.3.2 Symbols on the device .....	9
1.4 Intended purpose of the device.....	10
1.4.1 Correct use.....	10
1.4.2 Incorrect use .....	10
1.5 Standards and directives.....	10
1.6 Safety notes on gases.....	11
<b>2. Delivery .....</b>	<b>12</b>
2.1 Packaging .....	12
2.2 Components standard equipment.....	12
2.3 Acceptance inspection .....	12
<b>3. Installation of the device .....</b>	<b>13</b>
3.1 Ambient conditions.....	13
3.2 Room ventilation .....	13
3.3 Space requirements .....	14
3.4 Transport.....	14
3.5 Stacking .....	15
3.6 Modifications .....	15
<b>4. Description of the device.....</b>	<b>16</b>
4.1 Front view.....	16
4.2 Rear view .....	17
4.3 Safety devices.....	18
4.4 Work space atmosphere .....	18
4.5 Sensor system .....	19
4.6 Door switch .....	19
4.7 Switchbox with supply interface .....	20
4.8 Work space components.....	21
<b>5. Start-up.....</b>	<b>23</b>
5.1 Preparing the work space .....	23
5.2 Mounting the door handle .....	23
5.3 Installing the shelf system .....	24
5.4 Gas connection .....	26
5.5 Power supply connection .....	27
5.6 RS 232 interface connection .....	28
5.7 Connecting the alarm contact .....	30
<b>6. Handling and control .....</b>	<b>32</b>
6.1 Power switch.....	32
6.2 Operating panel.....	32
6.3 Control self-test.....	33
6.4 Setting the nominal temperature value .....	34
6.5 Setting the CO <sub>2</sub> nominal value.....	34
6.6 Activating the stacked incubator mode .....	35
6.7 Activating the auto-start routine .....	36
6.8 Reading failure codes .....	38

## Contents

6.9	Failure code list .....	41
6.10	Resetting the thermal protection .....	42
<b>7.</b>	<b>Operation .....</b>	<b>43</b>
7.1	Preparing the device .....	43
7.2	Starting operation.....	43
<b>8.</b>	<b>Shut-down.....</b>	<b>45</b>
8.1	Shutting the device down .....	45
<b>9.</b>	<b>Cleaning and disinfection.....</b>	<b>46</b>
9.1	Cleaning .....	46
9.2	Decontamination procedures .....	46
9.2	Wipe/Spray disinfection.....	46
<b>10.</b>	<b>Maintenance.....</b>	<b>51</b>
10.1	Inspections and checks.....	51
10.2	Service intervals.....	51
10.3	Preparing the temperature calibration.....	52
10.4	Temperature calibration procedure .....	53
10.5	Preparing the CO <sub>2</sub> calibration .....	54
10.6	CO <sub>2</sub> calibration procedure .....	55
10.7	Replacing the sterile filters .....	56
10.8	Replacing the device fuses .....	56
10.9	Replacing the door seal .....	57
<b>11.</b>	<b>Spare parts and accessories.....</b>	<b>58</b>
11.1	List of spare parts and accessories.....	58
<b>12.</b>	<b>Technical data.....</b>	<b>60</b>
<b>13.</b>	<b>Disposal .....</b>	<b>63</b>
<b>14.</b>	<b>Principles of good microbiological practice.....</b>	<b>64</b>
<b>15.</b>	<b>Device log .....</b>	<b>66</b>
<b>16.</b>	<b>Certificate of decontamination.....</b>	<b>67</b>

## Figures

Fig. 1	Device dimensions and clearance .....	14
Fig. 2	Lift points .....	14
Fig. 3	Stacking .....	15
Fig. 4	Front view .....	16
Fig. 5	Rear view .....	18
Fig. 6	Temperature and CO <sub>2</sub> sensor .....	19
Fig. 7	Door switch .....	19
Fig. 8	Supply interfaces .....	20
Fig. 9	Work space layout, Water reservoir .....	20
Fig.10	Rear panel openings .....	22
Fig.11	Door handle .....	23
Fig.12	Support rail installation/removal .....	24
Fig.13	Center strut/gas humidification installation .....	25
Fig.14	Gas pressure hose installation .....	26
Fig.15	Power supply connection .....	27
Fig.16	RS 232 interface connection .....	28
Fig.17	Example of a connection scheme for an external alarm system ...	31
Fig.18	Power switch .....	32
Fig.19	Operating panel functions .....	32
Fig.20	Blower wheel/Cover removal .....	50
Fig.21	Temperature calibration .....	52
Fig.22	CO <sub>2</sub> calibration .....	54
Fig.23	Sterile filter replacement .....	56
Fig.24	Device fuse replacement .....	56
Fig.25	Door seal replacement .....	57
Fig.26	Gas consumption .....	62

**1.**

**General Notes**

The following are the addresses of the international Thermo Electron LED GmbH sales organisations.

**Postanschrift Deutschland**

Thermo Electron LED GmbH  
Robert-Bosch-Straße 1  
D - 63505 Langenselbold

**Postal address USA**

Thermo Fisher Scientific  
168 Third Avenue  
Waltham, MA 02451  
USA

**Enquiries from Germany**

**Phone**

Sale 0800 1 536376

Service 0800 1 112110

**Fax**

Sale/Service 0800 1 112114

**E-Mail**

info.labequipment@thermo.com

**Enquiries from North America**

**Phone**

+1 800-879 7767

**Fax**

+1 828-658 0363

**E-Mail**

**Enquiries from Latin America**

**Phone**

+1 828-658 2711

**Fax**

+1 828-645 9466

**E-Mail**

info.labequipment@thermo.com

**Enquiries Europe, Middle East and Africa**

**Tel.**

+ 49 (0) 6184 / 90-6940

**Fax**

+ 49 (0) 6184 / 90-6772

**E-Mail**

info.labequipment@thermo.com

**Enquiries from Asia Pacific**

**Phone**

+852-2711 3910

**Fax**

+852-2711 3858

**E-Mail**

info.labequipment@thermo.com

## 1.1 General safety instructions

These operating instructions describe the CO<sub>2</sub> incubator BB 15.

The CO<sub>2</sub> incubator has been manufactured in keeping with the latest technological developments and is operationally safe. However, the device may present potential hazards, particularly if it is operated by inadequately trained personnel or if it is not used in accordance with the intended purpose. Therefore, the following must be observed to prevent accidents:

- The CO<sub>2</sub> incubator must only be operated by trained and authorized personnel.
- For personnel operating this device, the operator must prepare written instructions in a reasonable form based on these operating instructions, the safety data sheets, the hygiene regulations and the applicable Technical Guidelines, in particular:
  - which decontamination measures are to be taken for the device and for the accessories used,
  - which safety measures are to be taken when gases and pressurized gas containers are used,
  - which measures are to be taken in case of an accident.
- Any repairs to the device must only be performed by adequately trained and authorized expert personnel.
- The contents of the operating instructions are subject to change without further notice.
- Concerning translations into foreign languages, the German version of these operating instructions is binding.
- Keep these operating instructions in the vicinity of the device so that safety instructions and important information is always accessible.
- Should you encounter problems that are not mentioned in these operating instructions, please contact Thermo Electron LED GmbH immediately for your own safety.

## 1.2 Warranty

Thermo Electron LED GmbH warrant the operation and the operational safety of the CO<sub>2</sub> incubator BB 15 only under the condition that:

- the device is operated and serviced exclusively in accordance with its intended purpose and as described in these operating instructions,
- the device is not modified,
- only original spare parts and accessories that have been approved by Thermo Electron LED GmbH are used,
- inspections and maintenance works are carried out at the specified intervals.

The warranty is valid from the date of delivery of the device to the operator.

## 1.

## General notes

## 1.3 Explanation of symbols

## 1.3.1 Symbols used in the operating instructions

**WARNING!**

is used if non-observance may cause serious or even lethal injuries.

**CAUTION!**

is used if non-observance may cause medium to minor injuries or damage.

**NOTE**

is used for applicational hints and useful information.



**Wear safety gloves!**



**Wear safety goggles!**



**Harmful liquids!**



**Electric shock!**



**Hot surfaces!**



**Fire hazard!**



1.

General notes

1.3.2 Symbols on the device



**1.****General Notes****1.4 Intended purpose of the device****1.4.1 Correct use**

The CO<sub>2</sub> incubator BB 15 is a laboratory device for preparing and cultivating cell and tissue cultures. The device allows the simulation of the special physiological ambient conditions for these cultures due to the exact control of:

- temperature,
- CO<sub>2</sub> content,
- an increased relative humidity.

The BB 15 has been designed for installation and operation in the following fields of application:

- Laboratories for cytobiological and biotechnological experiments of safety levels L1, L2, and L3.

The CO<sub>2</sub> required for the incubator is supplied to the device from a separate gas supply system, either from gas cylinders or from a central pressurized gas container.

The layout of the gas supply system must ensure that the operating pressure of the gas supply lines can be set to a range between 0.8 bar (min.) to 1 bar (max.) and that the pressure cannot be changed.

Depending on the capability of the gas supply system, several devices may be connected to one gas cylinder.

The CO<sub>2</sub> incubator is suited for continuous operation.

**1.4.2 Incorrect use**

Do not use cell or tissue cultures in the device that are not in accordance with the regulations of safety levels L1, L2, and L3.

Do not use tissues, substances or liquids that:

- are easily ignitable or explosive,
- release vapors that form combustible or explosive mixtures when exposed to air,
- release poisons.

**1.5 Standards and directives**

The device is in accordance with the following standards and guidelines:

- DIN EN 61010-1:2010+Korr. 2011
- DIN EN 61010-2-010:2014
- Low Voltage Directive 2014/35/EU
- EMV-Directive 2014/30/EU
- DIN EN 61326-1:2013
- DIN EN 50581:2012

For other countries, the applicable national regulations are binding.

## 1.6 Safety notes on gases

### Carbon dioxide (CO<sub>2</sub>):

As CO<sub>2</sub> is rated as a harmful gas, certain safety instructions must be observed when the CO<sub>2</sub> incubator is started up and when the device is operated.



#### NOTE – Personnel instruction

**Personnel operating devices with a CO<sub>2</sub> supply must be instructed about the requirements for the handling of CO<sub>2</sub> before starting their work:**

- **Correct operation of pressurized gas containers and gas supply systems,**
- **Obligation to report damages and shortcomings in CO<sub>2</sub> supply lines,**
- **Measures to be taken in case of accidents or failures.**

These instructions must be repeated at appropriate intervals and must incorporate the particular operating instructions of the gas supplier.



#### WARNING - Suffocation hazard!



**CO<sub>2</sub> released in large amounts into the room atmosphere may cause suffocation. If CO<sub>2</sub> is released, initiate safety measures immediately!**

- **Leave the room immediately and do not allow others to enter the room!**
- **Inform security service or fire department!**

## 2.

## Delivery

### 2.1 Packaging

The CO<sub>2</sub> incubator BB 15 is delivered in a stable packaging box. All packaging materials can be separated and are reusable:

#### Packaging materials

- |                     |                      |
|---------------------|----------------------|
| • Packaging carton  | Recycled paper       |
| • Foam elements     | Styrofoam (CFC-free) |
| • Pallet            | Untreated wood       |
| • Packaging film    | Polyethylene         |
| • Packaging ribbons | Polypropylene        |

### 2.2 Components standard equipment

Delivery	CO <sub>2</sub> incubator with single glass door and with continuous shelves (standard version)
Shelf	3
Shelf support post	4
Shelf support rail	6
Insert for pressure compensation opening	1
Plug for pipe channel	1
Power supply cable	1
Connector, potential-free contact	1
Spare caps, set	1
CO <sub>2</sub> connecting hose set	1
Immersion water pump	1
Open-end wrench, 24 mm	1
Allen wrench 2 mm for blower wheel	1
Allen wrench 3 mm for blower wheel cover	1
Operating instructions	1

### 2.3 Acceptance inspection

After the device has been delivered, check the delivery immediately for:

- completeness,
- possible damages.

**If damages are detected or if components are missing, please contact the carrier and Thermo Electron LED GmbH immediately.**

### 3.1 Ambient conditions

The device must only be operated in locations that meet the particular ambient conditions listed below.

#### Requirements:

- Draft-free and dry location.
- The minimal distance to adjacent surfaces must be observed on all sides (see Section 3.3).
- The operating room must be equipped with appropriate room ventilation.
- Solid, level, fire-proof surface.
- Vibration-proof substructure (floor stand, lab table) capable of bearing the weight of the device and accessories (particularly if several devices are stacked).
- To ensure a constant incubation temperature of 37 °C, the ambient temperature must be within a range of +18 °C to +33 °C.
- Relative humidity up to 80 % (max.).
- Avoid direct exposure to sunlight.
- Devices that produce excessive heat should not be used near the location of the CO<sub>2</sub> incubator BB 15.

### 3.2 Room ventilation

When CO<sub>2</sub> is supplied, the work space of the incubator is slightly pressurized. The pressure is released through the pressure compensation opening into the operating room.

As the pressure compensation and any opening of the glass door/gas tight screen during the operation of the device will release **very small quantities of CO<sub>2</sub>** into the operating room, the room ventilation must be capable of carrying the released gas safely off into the open.

In addition, heat dissipating from the device during permanent operation may cause a change in the room climate.

- Therefore, the BB 15 must only be installed in rooms with sufficient ventilation.
- Do not install the device in room recesses without ventilation.
- The room ventilation should be a technical ventilation that is in accordance with the requirements of DGUV Information 213-850 or some other suitable ventilation system with appropriate capacity.

### 3. Installation of the device

#### 3.3 Space requirements

**Fig. 1:** When installing the device, make sure that the installation and supply connections are freely accessible. The control box at the rear panel of the device may serve as a spacer to adjacent objects. The side distances given are minimal distances.

To protect the CO<sub>2</sub> incubator against contamination, use a floor stand even if the device is installed near the floor. The height of the floor stand should not be less than 200 mm.

Several floor stands and carriers are available as options from Thermo Electron LED GmbH (part numbers see Section 11.1, "Spare parts and accessories").



**NOTE – Accessibility of the devices**

To ensure the accessibility for care and maintenance works, keep larger side and rear distances.

#### 3.4 Transport

**Fig. 2:** For transport do not lift the device using the doors or components attached to the device (e.g. control box on rear panel) as lift points.



**NOTE – Lift points**

Lift the device only using the lift points shown in Fig. 2.



**NOTE – Lift points**

To avoid over load related injuries, for example muscle strains and disk degeneration, never try to lift the device alone.

To avoid injuries from falling off loads, always wear personal protective equipment while carrying the device, for example safety shoes.

To avoid crushing the fingers or hands (especially by pinching when closing the door) or damaging the device, only the lifting points provided may be used.

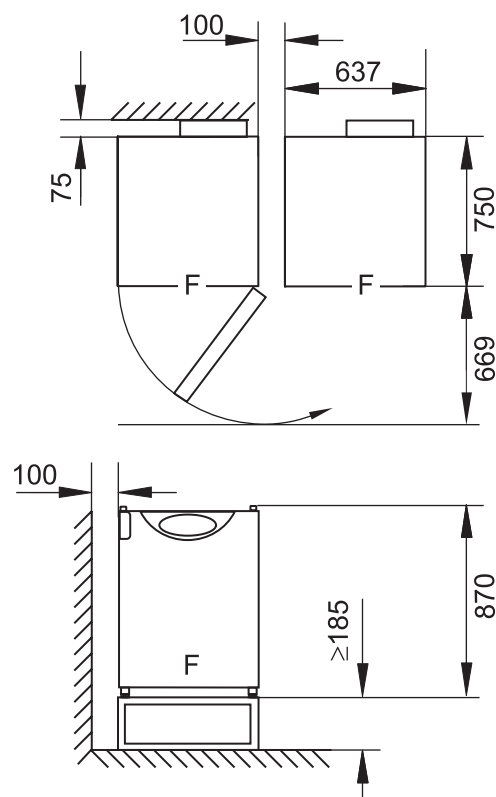

Fig. 1  
Device dimensions and clearance in mm,  
F = Front

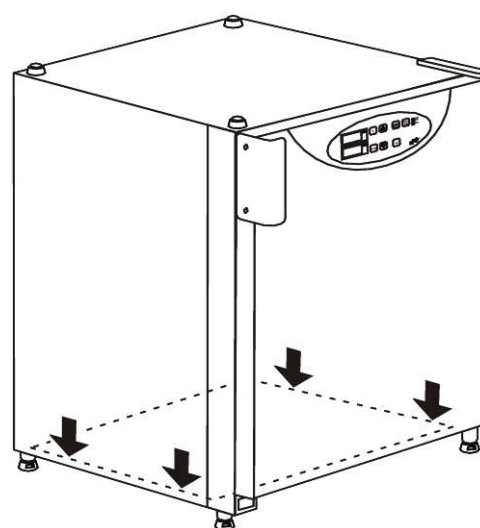

Fig. 2  
Lift points

### 3.5 Stacking

**Fig. 3:** Two BB 15 devices can be stacked on top of each other. The stacking elements [1] and [2] secure the devices on top of each other.

If the devices are placed onto mobile racks, ensure that the rollers [4] are secured by an arresting device during operation. For reasons of stability, the rollers should be oriented to the front.

When stacking the incubators, the stacked incubator function must be activated on the upper unit. This function adjusts the parameters of the upper unit to compensate any heat transmission between the two units.



**NOTE – Transporting stacked devices**

**The stacking elements are not connecting elements. Therefore, the transport of stacked devices on sloped surfaces is not allowed.**

### 3.6 Modifications

The outer door and the glass door can be equipped with left or right side fasteners. The door fastening can also be reversed later.



**NOTE – Modifications**

**Retrofits and modifications must only be performed by the Technical Service of Thermo Electron LED GmbH.**

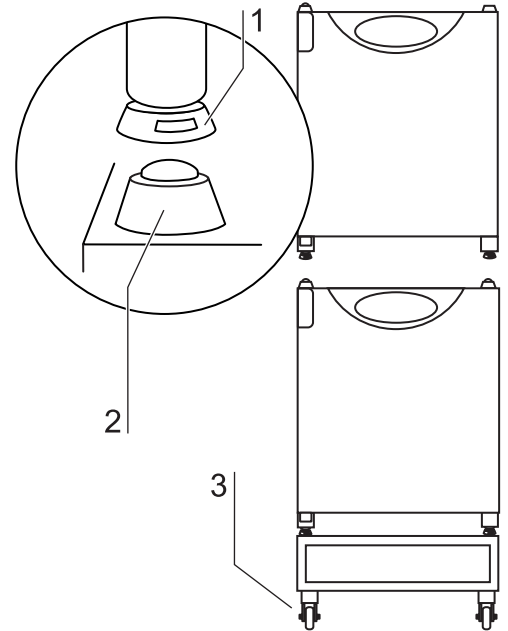

Fig. 3  
Stacking

## 4. Description of the device

### 4.1 Front view

- |      |  |      |                              |
|------|--|------|------------------------------|
| [1]  | Stacking elements                            | [11] | Stand, height-adjustable     |
| [2]  | Plug caps                                    | [12] | Nameplate                    |
| [3]  | Glass door                                   | [13] | Power switch                 |
| [4]  | Measuring cell with blower wheel and sensors | [14] | Support rail                 |
| [5]  | Door switch                                  | [15] | Shelf                        |
| [6]  | Pressure compensation opening with insert    | [16] | Latch, glass door            |
| [7]  | Measuring opening                            | [17] | Support hook for shelf       |
| [8]  | Outer door                                   | [18] | Access port with plug        |
| [9]  | Door handle                                  | [19] | Glass door seal, replaceable |
| [10] | Outer door seal, replaceable                 |      |                              |

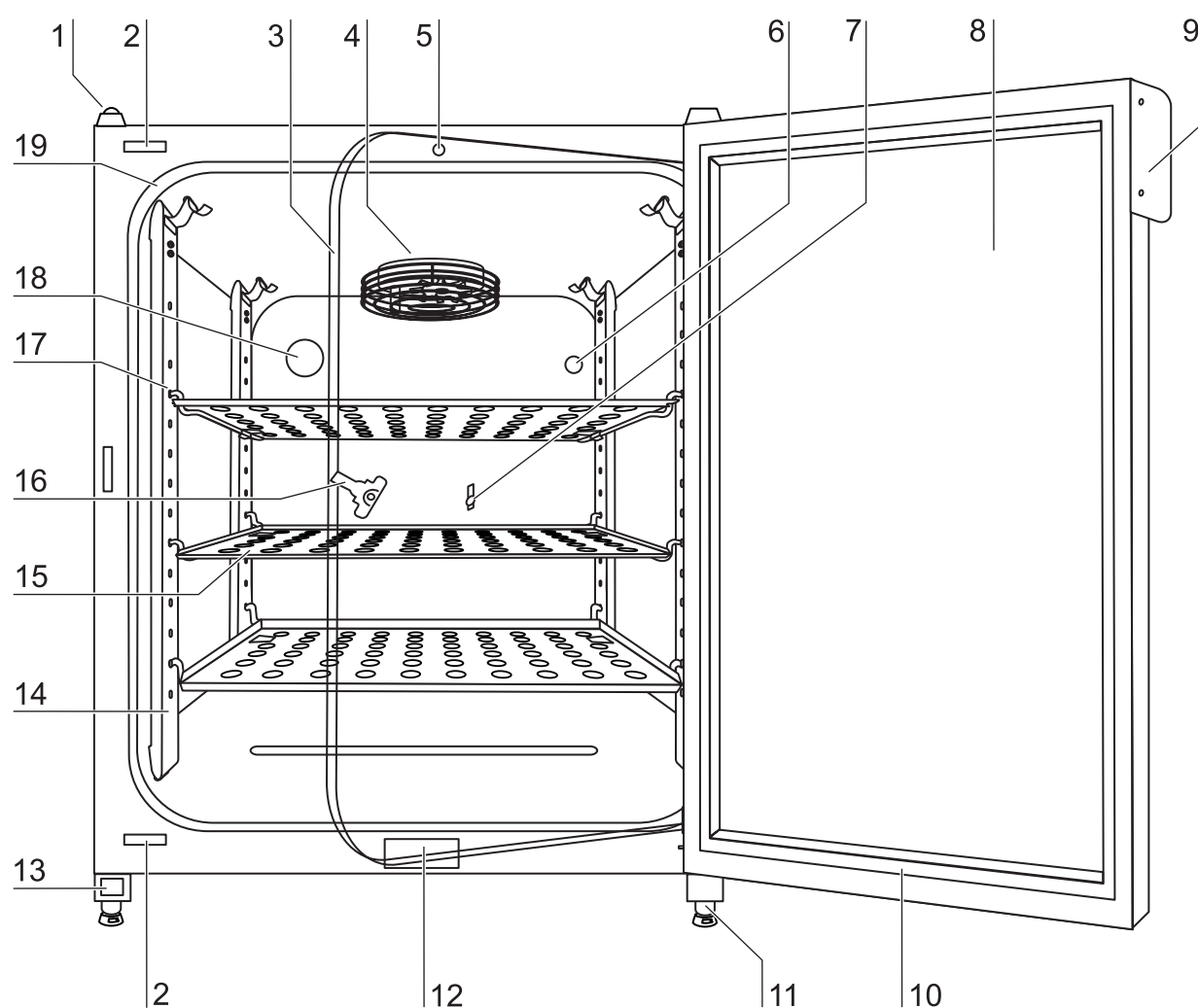

Fig. 4  
Front view



## 4. Description of the device

### 4.2 Rear view

- [1] Stacking elements
- [2] Pressure compensation opening
- [3] Access port, Ø 42 mm
- [4] Switchbox with supply interfaces
- [5] CO<sub>2</sub> gas container

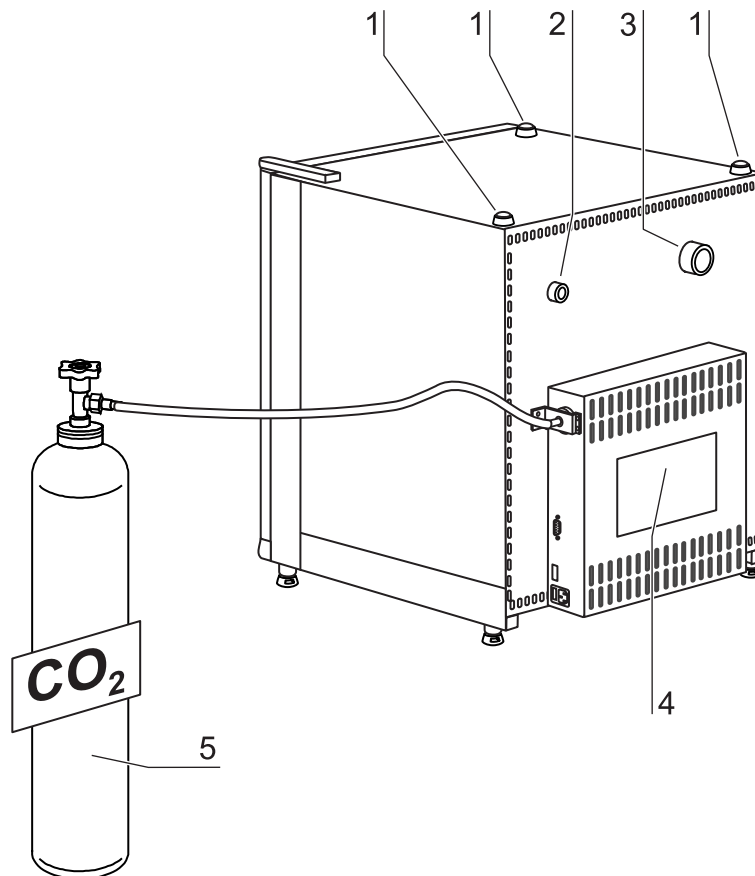

Fig. 5  
Rear view

## 4. Description of the device

### 4.3 Safety devices

The device is equipped with the following safety devices:

- A door switch interrupts the CO<sub>2</sub> supply and the work space heating when the glass door is opened.
- An independent thermal protection protects the samples from harmful overheating in the event of a failure.
- A pressure compensation opening ensures pressure compensation in the device work space.
- Audible and visual alarms indicate failures during operation.

### 4.4 Work space atmosphere

In the work space of the incubator, the particular physiological ambient conditions for the preparation and cultivation of cell and tissue cultures are simulated. The work space atmosphere is determined by the following factors:

- Temperature,
- Relative humidity,
- CO<sub>2</sub> concentration.

#### **Temperature:**

To ensure undisturbed operation, the temperature in the operating room must be at least 18 °C and the incubation temperature must be at least 3 °C higher than the room temperature.

The heating system controls the incubation temperature from this temperature threshold up to 55 °C. The principle of air jacket heating and the additional, separate heating of the outer door minimize the risk of condensate formation on the side walls, at the ceiling of the work space, and at the glass door.

#### **Relative humidity:**

The water tray of the work space can hold 3.0 liters of processed water. The heating of the work space causes evaporation of the water, thereby ensuring a constant humidity within the work space. Under normal operating conditions and at the usual incubation temperature of 37 °C, a constant relative humidity of approx. 95 % is achieved in the work space.

If heated containers are removed and put back into the work space, the elevated humidity and the cooling may cause condensate to form on the outer sides of the container.

For humidification, processed water of the following quality is required:

- demineralized and either distilled or autoclaved for sterilization,
- or
- completely deionized and either distilled or autoclaved for sterilization.

#### **CO<sub>2</sub> supply:**

To ensure correct growth conditions for the cell and tissue cultures, the work space is supplied with CO<sub>2</sub>. The pH of the bicarbonate-buffered culture media largely depends on the CO<sub>2</sub> content of the work space atmosphere. The CO<sub>2</sub> content of the work space atmosphere can be controlled within a range of 0-20 %.

The CO<sub>2</sub> must be of the following quality:

- Purity 99.5 % min.,
- or
- medical grade.

#### 4.5 Sensor system

**Fig. 6:** The blower wheel and two sensor modules are integrated in the baseplate [1] of the measuring cell:

- Sensor [2] for the measurement of the work space temperature and of the thermal protection,
- CO<sub>2</sub> sensor [3] for the measurement of the CO<sub>2</sub> content in the work space atmosphere.

The sensor for the measurement of the work space temperature as well as the CO<sub>2</sub> sensor form part of the control system of the device. Their measured values are compared to the set nominal values. Based upon this data, the control system controls heating and CO<sub>2</sub> supply.

The blower intermixes the supplied gases and ensure uniform temperature distribution within the work space.

The thermal protection has been preprogrammed at the factory and cannot be changed. It protects the stored cultures from overheating. If the temperature is exceeded by more than 1 °C, the thermal protection responds, and the work space temperature is automatically reduced to the set nominal value so that the incubation process can be continued even in case of a failure. Any response of the thermal protection will simultaneously trigger an audible and visual alarm.

#### 4.6 Door switch

**Fig. 7:** A door switch [1] is installed in the upper edge of the work space opening. If the door switch is activated by opening the glass door, the gas supply and the heating of the work space are interrupted, and the display shows will flash.

If the door remains open for more than 30 seconds, a short acoustic alarm sound. If the door remains open for more than 10 minutes, the acoustic alarm sounds continuously.

The outer door can only be closed after the glass door has been latched properly.

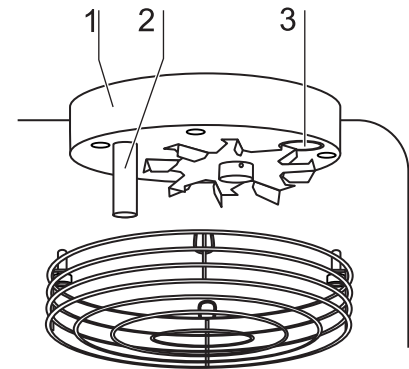

Fig. 6  
Temperature and CO<sub>2</sub>  
sensor

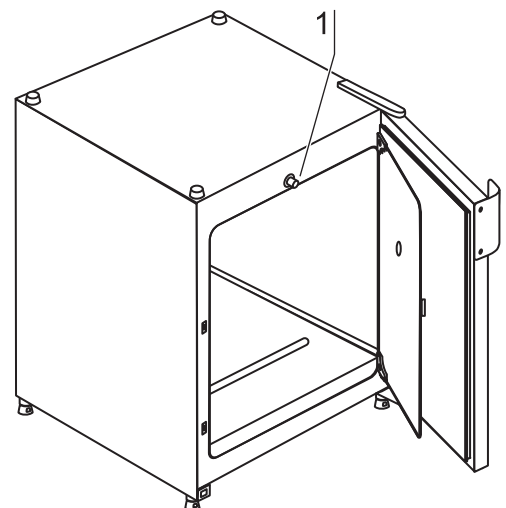

Fig. 7  
Door switch

#### 4.7 Switchbox with supply interface

All supply connections are installed in the switchbox at the rear of the device.

##### Gas connection:

**Fig. 8:** The gas supply line between the device and the gas supply system is connected using the supplied connecting hoses. CO<sub>2</sub> is supplied to the device through a separate connecting sleeve [1].

The process gas must be supplied to the device at a fixed pressure that has been preset within a range of 0.8-1.0 bar, this must remain unchanged.

Before the gas is fed into the work space, it flows through a sterile filter with a separation rate of 99.97 % for a particle size of 0.3 µm (HEPA filter quality).

##### Label:

**Fig. 8:** The label [2] contains information about gas supply, an alarm contact terminal legend, and notes about the electrical fusing of the device.

##### RS 232 interface:

**Fig. 8:** Via the RS 232 interface [3], the incubator can be connected to the serial interface of a PC. This connection allows the computer-aided acquisition and documentation of the major operating parameters (temperature, CO<sub>2</sub> concentration, failure codes, etc.).

##### Alarm contact:

**Fig. 8:** The device can be connected to an on-site, external alarm system (e.g. telephone system, building monitoring system, visual or acoustic alarm system). For this purpose, a potential-free alarm contact [4] is preinstalled in the device.



#### NOTE – Alarm contact

**The alarm contact receives only messages caused by work space atmosphere conditions (temperature or gas).**

##### Power supply connection:

**Fig. 9:** The power supply connection [5] of the device is established via a cable with a connector for non-heating appliances. The holder for the two device fuses is integral to the power supply socket.

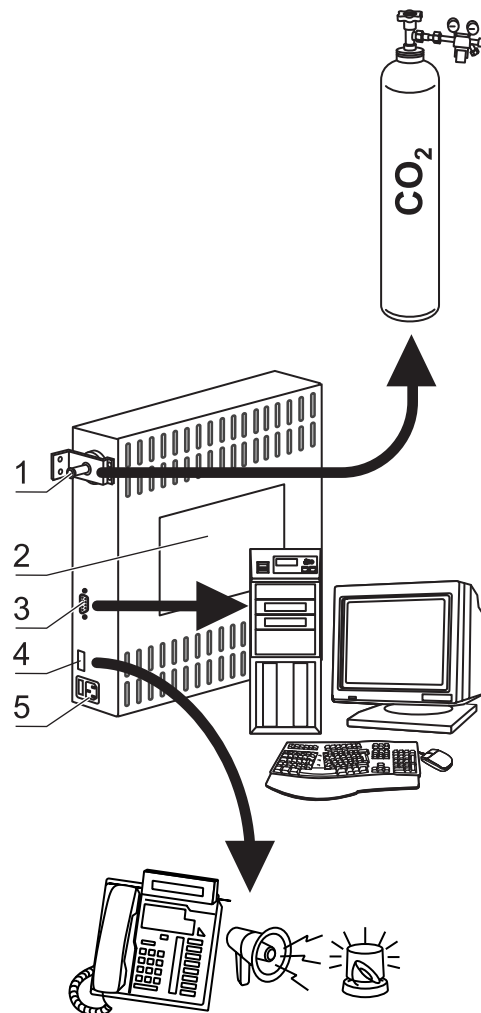

Fig. 8  
Supply interfaces

### 4.8 Work space components

The working surface of the incubator has been designed to minimize the surface area. This helps to reduce contamination and promotes easy cleaning.

#### Internal chamber:

All components of the work space are made of stainless steel and have a burnished, absolutely smooth and easy-to-clean surface. Any embossing have a large radius.

As an option, the interior container, the shelf system, and the blower wheel with its cover can be made of copper material.



#### NOTE – Oxidation of copper components

**When exposed to heat and humid air, the copper material of the interior container will oxidize. This results in a discoloration of the copper components during the test run for checking the device functions.**

**Do not remove the oxide layer during routine cleaning as this has an antimicrobial effect.**

**Fig. 9:** The components of the shelf system can be removed easily so that only the easily treatable, surface-reduced internal chamber [1] remains in the work space for cleaning and manual disinfection works.

#### Water reservoir:

**Fig. 9:** The water reservoir [2] is integral to the internal chamber floor and inclines toward the rear. The embossing in the water tray is used to indicate minimum level [3] and the maximum level [4].

#### Heating system:

An air jacket heating is used for heating the work space. The arrangement of the heating elements ensures that condensate formation above the water reservoir is prevented as fast as possible.

The outer door of the device is also heated. The heat radiated onto the interior glass door/gas tight screen prevents condensate formation. The work space of the device always remains visible, despite high humidity.

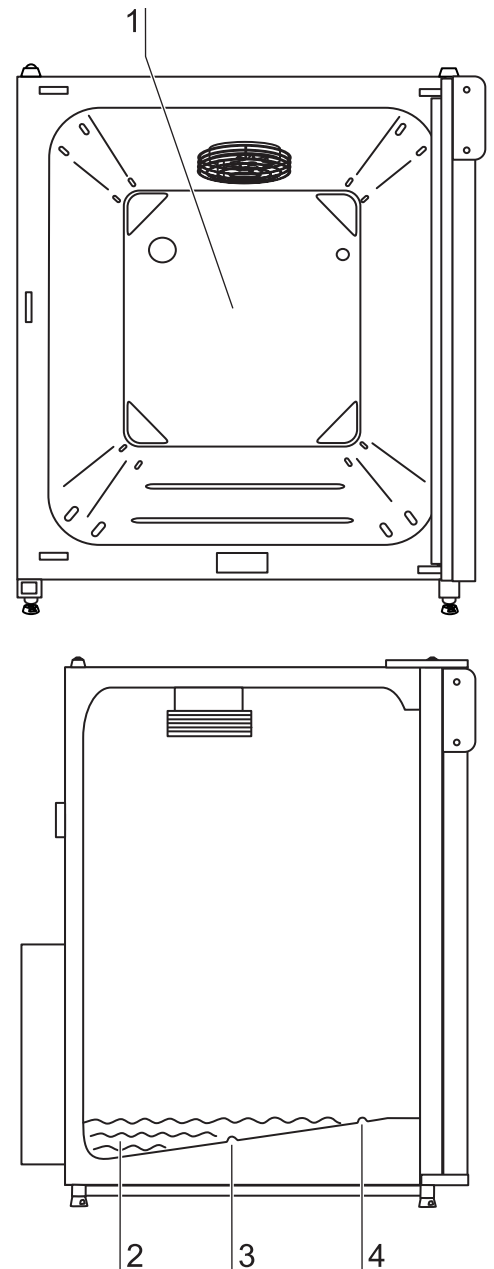

Fig. 9  
Work space layout,  
Water reservoir

## 4. Description of the device

### Rear panel openings:

**Fig. 10:** A sealable access port [1] allows cables, hoses or additional sensors to be routed into the work space of the device. A pressure compensation opening with insert [2] at the rear panel of the device allows a compensation between the pressures in the work space and in the operating room.



### NOTE – Operating conditions

When accessories are to be operated in the work space of the CO<sub>2</sub> incubator, the ambient condition requirements must be observed (see table below). The energy introduced into the work space affects the beginning of the temperature control range. When additional heating sources are introduced into the work space, condensation (e.g. at the glass door) may occur.

Introduced energy	Control range of the temperature	
	General	Example: RT* = 21 °C
0 W	RT + 3 °C	24 °C
5 W	RT + 6.5 °C	27.5 °C
10 W	RT + 9.5 °C	30.5 °C
15 W	RT + 13 °C	34 °C
20 W	RT + 16 °C	37 °C
*RT = Ambient temperature		

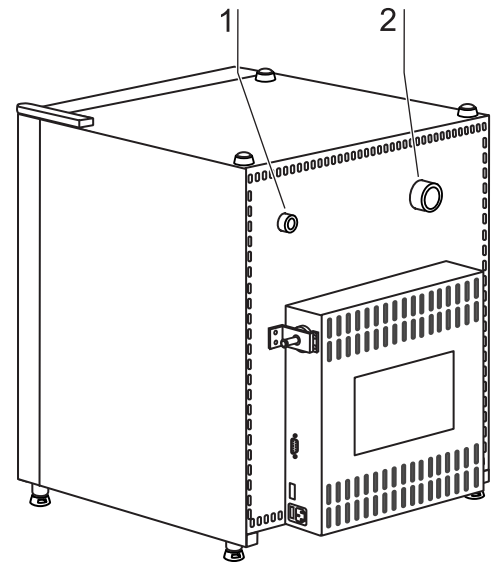

Fig. 10  
Rear panel openings

### 5.1 Preparing the work space

The incubator is not delivered in a sterile state. Before the initial start-up, the device must be decontaminated. Before the decontamination is performed, the following work space components must be cleaned:

- Support rails,
- support hooks,
- shelves,
- gas humidification,
- work space surfaces,
- work space seals and gaskets,
- glass door



**NOTE – Decontamination**

For details about the cleaning and disinfection of the device, see Section 9.



**NOTE – Acclimatization**

Before commissioning, the device must be acclimatized.

- Before switching on the device, set it up in the operating room for approx. 2 hours at the anticipated operating room temperature.
- Open the appliance door.

### 5.2 Mounting the door handle

**Fig. 11:** The door handle [4] can be installed to the face of the outer door [2] either at the upper position [1] or at the lower position [3]. Two holes are drilled in each position.

1. Install the door handle by using the 2 self-tapping screws [5] provided.
2. Cap the unused holes with the protective caps.

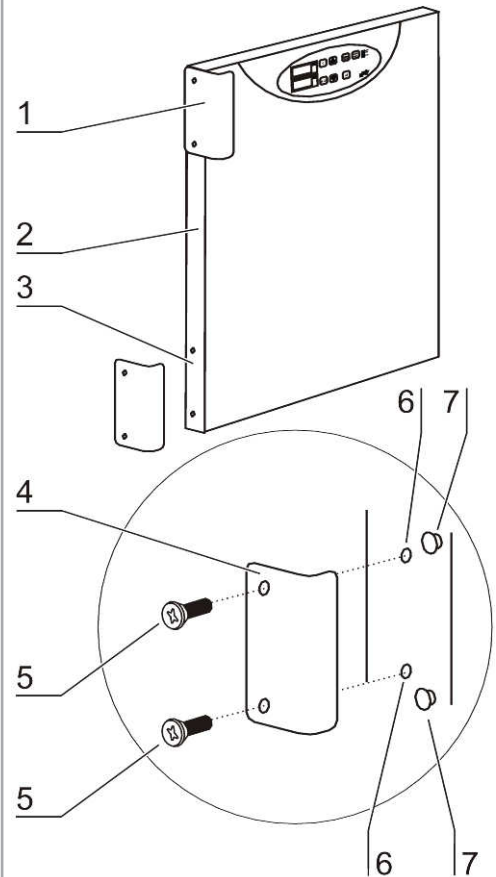

Fig. 11  
Door handle

### 5.3 Installing the shelf system

Tools are not required for the installation of the shelf system. The support rails are secured using spring pressure. After the support hooks have been inserted into the rail, the shelves are pushed onto the support hooks.

#### Support rail installation/removal:

**Fig. 12:** The support rails are held at the sides by embossing [2] and [5] and secured by the embossing [1] and [6]. The support rails marked with (◇) are inserted at the rear panel of the device with the lock springs [3] facing upward.

1. Position support rail [4] onto the lower embossing [6] and tilt toward the work space side wall so that the rail is positioned over the two embossings [5] and [2].
2. Clamp lock spring [3] behind upper embossing [1].
3. To remove the support rails, pull lock spring tab down and out of the embossing to remove rail.

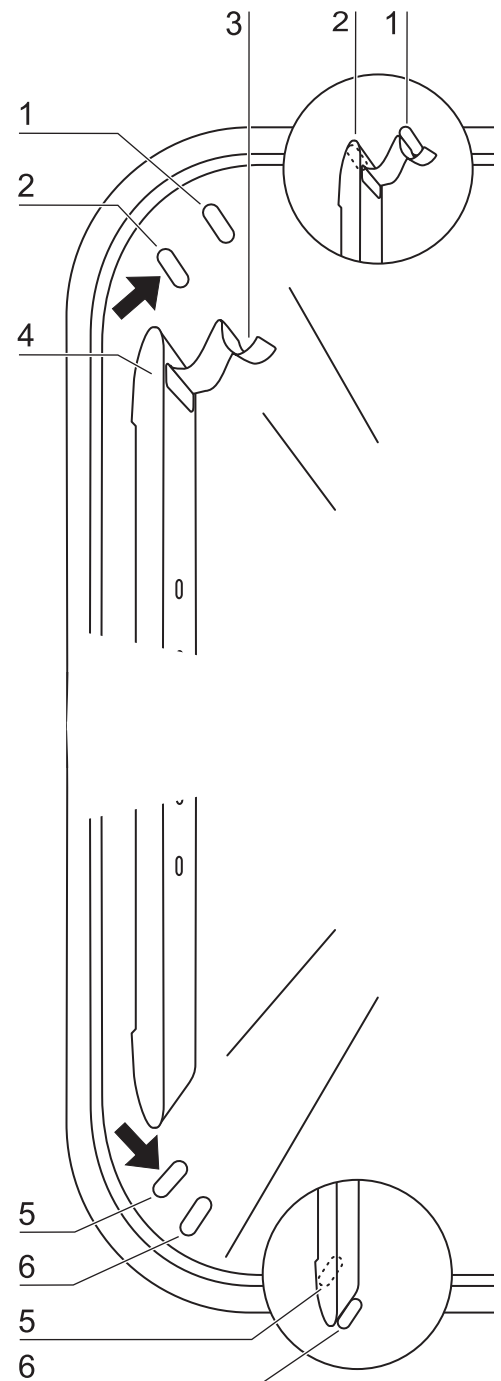

Fig. 12  
Support rail installation/  
removal



**Installing the shelf supports:**

1. **Fig. 13:** Insert the shelf supports [3] into the perforations [1] of the support rail with the bar facing down.
2. Make sure that the two vertical elements [2] of the shelf support are flush with the support rail.

**Installing the shelves:**

1. **Fig. 13:** Push the shelf [4] onto the shelf supports with the tilt protection [5] facing the rear panel of the device. The tilt protection [5] is also used as a guide for the shelf.
2. Slightly raise shelf so that the withdrawal stop [6] can be routed over the shelf supports.
3. Make sure that the shelf supports are positioned in the two tilt protectors in a way that it can move freely.

**Levelling the device:**

1. Position a bubble level on the center shelf.
2. Rotate the adjustable device stands using the supplied 24 mm wrench until the shelf is positioned horizontally in all directions. Perform the adjustment of the device stands from left to right and from rear to front.

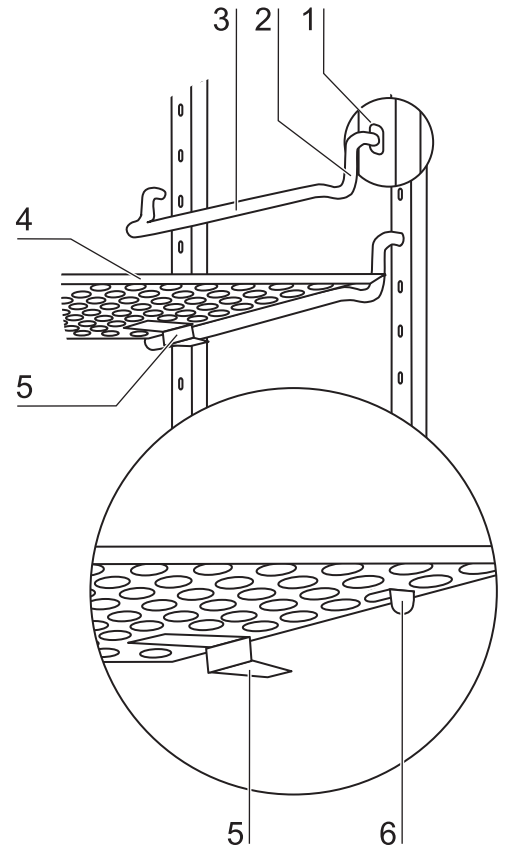

Fig. 13  
Shelf support/sheet/  
insert installation

## 5.

## Start-up

## 5.4 Gas connection

**NOTE – Gas quality**

CO<sub>2</sub> must be of the following qualities:

- Purity 99.5 % min,
- medical grade.

**CAUTION – Overpressure!**

The operating pressure of the gas applied to the device must not exceed 1 bar. If the gas is supplied at a higher pressure, the valves integral to the device may not close correctly and the gas supply control may be impaired. Set the gas supply to a range between 0.8 bar min. and 1.0 bar max. and make sure that this pressure setting cannot be changed!

**NOTE – Pressure compensation opening**

To ensure permanent pressure compensation, the pressure compensation opening must not be connected to an exhaust air system. The pipe of the pressure compensation opening must not be extended or redirected.

**NOTE – Access port**

If the access port is not used, it must be capped during operation.

**CO<sub>2</sub> connection**

**Fig. 14:** The gas supply from the gas supply system to the device is achieved using the supplied flexible gas pressure hoses:

1. Connect gas pressure hose [1] to the sleeve of the gas supply system.
2. Remove protective cap [3] from sterile filter.
3. Slide hose clamp [2] onto gas pressure hose and connect hose to the sleeve of the sterile filter.
4. Secure gas pressure hose to the sleeve of the sterile filter using the hose clamp.

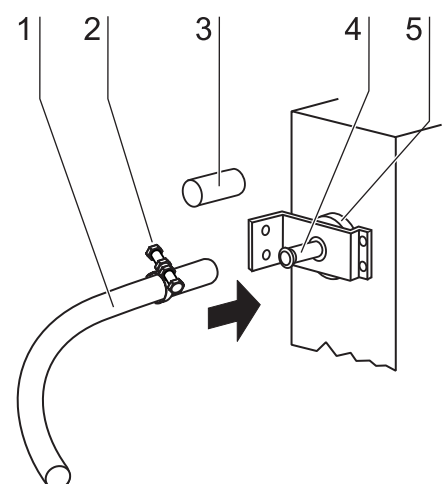

Fig. 14  
Gas pressure hose  
installation,  
CO<sub>2</sub> connection

### 5.5 Power supply connection



**WARNING – Electric shock!**



**Contact with current-carrying components may cause a lethal electric shock.**

**Before connecting the device to the power supply, check plug and connection line for damage.**

**Do not use damaged components when connecting the device to the power supply!**

The device must be connected only to a correctly installed ground fault circuit interrupter and grounded power supply source:

- Fusing T 16 A
- Circuit breaker B 16

#### Connection to the power supply system:

1. Before connecting the device to the power supply, check to see if the voltage of the power supply corresponds with the specifications on the nameplate at the front of the device. If the ratings given for voltage (V) and current (A) are not correct, the device must not be connected to the power supply.
2. **Fig. 15:** Connect the connector for non-heating appliances [2] to the socket [1] at the control box of the device.
3. Connect the grounding plug [3] of the power supply cable to a correctly grounded and fused socket.
4. Make sure the power supply cable is not subjected to tensile or compressive force.
5. The power socket for the mains connection must always be accessible in the event of an emergency stop. The power plug must be clearly visible to the user and freely accessible at all times.

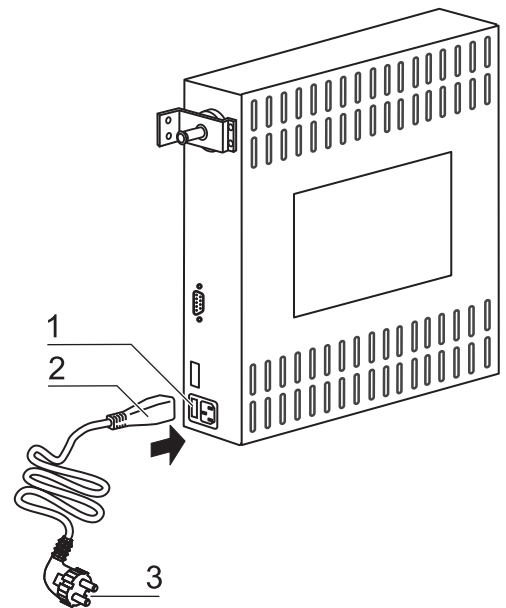

Fig. 15  
Power supply connection

## 5. Start-up

### 5.6 RS 232 interface connection

The RS 232 interface has been designed for a cable connection with 9-pin connectors and a contact assignment of 1:1.

#### Connection of the device:

1. Turn PC off.
2. **Fig. 16:** Connect the connector [2] of the serial interface cable [3] (not comprised in the scope of delivery) to the socket [1] at the supply interface at the rear of the device.
3. Connect the remaining other connector [4] to an unassigned slot COM 1/COM 2 etc. at the PC.
4. Turn PC on.

#### Transfer protocol:

The interface must be configured as follows:  
9600 baud, 8 data bits, 1 stop bit, no parity.

#### Command sequences:

Data communication is achieved with a defined structure of command sequences (frames).

#### Frame structure:

<STX | command | data | BCC | ETX>

#### Command:

Bit 0 - 3 = data field length in byte  
Bit 4 - 7 = command

#### Check sum:

BCC = 1 - complement  
(command XOR data XOR ... XOR dataN  
XOR FF<sub>H</sub>)

#### Command list - Reading control loop data

Command:

0110 0001 (61<sub>H</sub>)

Data:

0001 0000 (10<sub>H</sub>) for temperature during incubation operation

0001 0001 (11<sub>H</sub>) for CO<sub>2</sub>

#### Device response for temperature and CO<sub>2</sub>

Data:

Nominal value x 10 (2 bytes, integer)

Nominal value (4 bytes, floating point number)

Internal use (5 bytes for CO<sub>2</sub>, otherwise 7 Bytes)

#### Command list - Requesting failure codes

Command:

1001 0000 (90<sub>H</sub>)

Data:

none

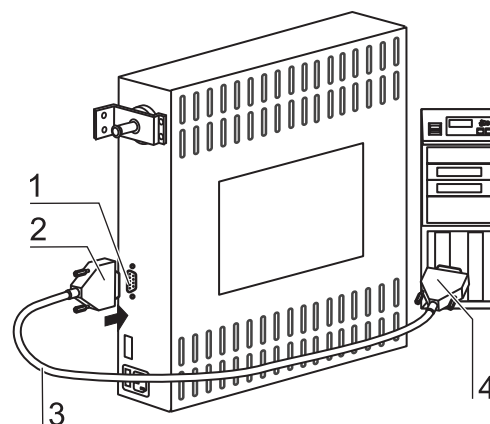

Fig. 16  
RS 232 interface

**Response - Reading failure codes**

The microprocessor returns a total of 10 bytes (5 integer values). Each integer value represents a current failure code in the assigned control loop (incubation temperature, CO<sub>2</sub> content, general).

The failure code "General failure" belongs to a superior failure that is shown simultaneously in all displays (e.g. failure code 99).

The error code for incubation temperature is shown in the temperature display, the codes for CO<sub>2</sub> are shown in the CO<sub>2</sub> display. Value "---" shows that there is no current failure.

**Faulty response from control unit:**

If a returned response is incomplete or faulty, the CPU responds with an NAK (15<sub>H</sub>, only 1 byte, without frame). Otherwise, the command code (with pertaining length information) is regarded as a response and the data that may be required is transmitted.

**Particularities during data communication:**

For the data communication between PC and microcontroller, the following particularities must be observed:

The microprocessor stores an **int or unsigned int** value with the sequence <Highbyte>, <Lowbyte> in the memory. For the PC, this sequence is reversed.

The microcontroller transmits these values in its format, i.e. the PC must reverse the sequence of the bytes. For floats, there is no difference.

**Example: Temperature data request and response**

Request

O2<sub>H</sub> 61<sub>H</sub> 10<sub>H</sub> 8E<sub>H</sub> 03<sub>H</sub>

Response:

O2<sub>H</sub> 6D<sub>H</sub> 01<sub>H</sub> 72<sub>H</sub> 38<sub>H</sub> 91<sub>H</sub> C7<sub>H</sub> 41<sub>H</sub> F5<sub>H</sub> 6B<sub>H</sub> F4<sub>H</sub> 43<sub>H</sub> 9E<sub>H</sub> 00<sub>H</sub> 32<sub>H</sub> 4B<sub>H</sub> 03<sub>H</sub>  
*integer float intern*  
 (37.0) (24.946)

## 5.7 Connecting the alarm contact



### NOTE – Expert work

Thermo Electron LED GmbH warrants the operational safety and the operativeness of the device only if installation and repairs are performed properly.

The connection of the device to an external alarm system must only be carried out by adequately trained and authorized expert electrical/telecommunication personnel!

### Function:

When failures occur in the temperature or gas control circuits, an alarm message is issued to the connected alarm/monitoring system. The potential-free contacts (1 changeover contact) have been laid out for the following circuits:

Circuit	Voltage	External fusing
Circuits with system voltage	max. 250 V ~	max. 6 A
SELV circuits (cf. VDE 0100, Part 410)	25 V ~	max. 2 A
	60 V =	max. 1 A
SELV-E circuits (cf. VDE 0100, Part 410)	50 V ~	max. 1 A
	120 V =	max. 0.5 A

### Alarm relay

Operating state	Contact 4 - 1	Contact 4 - 3
No failure, power off	X	O
No failure, power on	O	X
Failure	X	X
X: Contact closed / O: Contact open		



### NOTE – Switching structure

For all failures reported by the device (sensor circuit open, deviation from the nominal value and door open for more than 10 minutes), the alarm relay changes state.

**Connection example:**

**Fig. 17:** The connector [5] for the connecting cable is comprised in the scope of delivery. The values for the operating voltage of the external circuits and of the fusing of the alarm system are given in the table above.

1. Connect the individual conductors [1] to [4] of the connecting cable as shown in the wiring diagram.
2. Connect the connector [5] of the alarm system connecting cable to the interface [6] at the control box at the rear panel of the device.

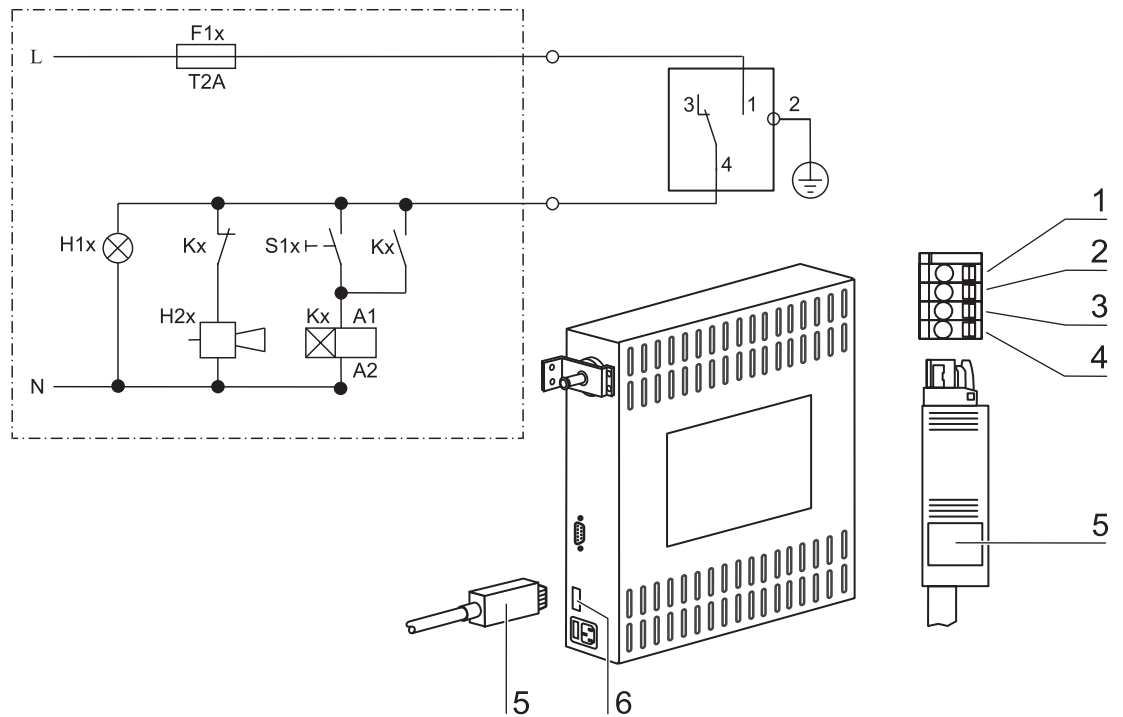

Fig. 17  
Example of a connection  
scheme for an external alarm  
system (changeover contact:  
device off, no failure)

## 6. Handling and control

### 6.1 Power switch

**Fig. 18:** Depending on which side the door hinges are installed, the power switch [1] is integral to the front cover [2] of one of the front device stands.

- To turn the device on:  
Press the power switch [1]; the switch illumination comes on.
- To turn the device off:  
Press the power switch; the switch illumination goes off.

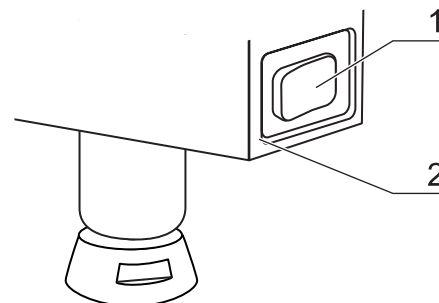

Fig. 18  
Power switch

### 6.2 Operating panel

**Fig. 19:** The operating panel is divided into three functional areas:

- 2 displays that show numeric values for temperature and CO<sub>2</sub> content.
- 7 keys for selecting functions and for entering data.
- 4 LEDs that show functions or operating states.

[1]	Key for setting temperature nominal value	[8]	Key for starting cal function
[2]	Key for increasing value	[9]	Key for reducing value
[3]	Key for reading failure codes/stopping acoustic alarm	[10]	Key for setting CO <sub>2</sub> nominal value
[4]	Key for activating auto-start	[11]	LED for indicating active CO <sub>2</sub> gas supply
[5]	LED for indicating active auto-start	[12]	CO <sub>2</sub> display
[6]	LED for indicating door (open door)	[13]	Temperature display
[7]	LED for indicating active overtemperature protection	[14]	Heating LED

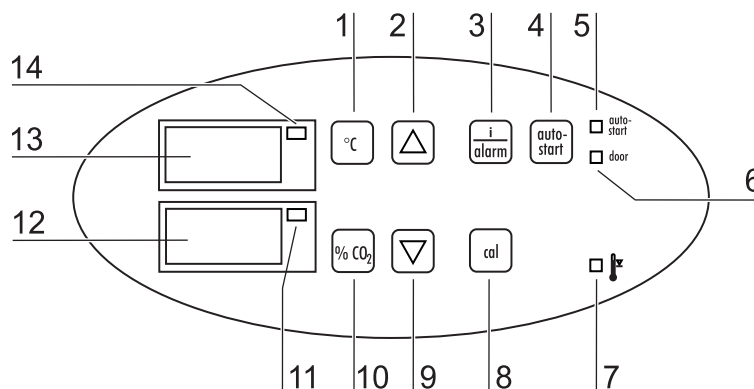

Fig. 19  
Operating panel functions



### 6.3 Control self-test

After the device has been turned on, the control goes through a test routine.

#### 1. Turn the device on

- ▶ Press power switch.
- All indicators on the operating panel come on, all displays show the numeric value 8 to indicate that the test routine is being run.

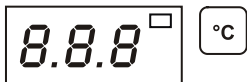

- The temperature display shows a three-digit number for the corresponding assembly/parameter set:
  - P 1: Operating and display board
  - P 2: Measuring cell
  - P 3: Main board
  - P n: Parameter number
 The CO<sub>2</sub> display shows the software version/device version.

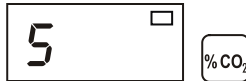
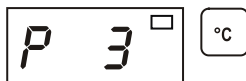

#### 2. Test routine completed

- The temperature display shows the current temperature value, the CO<sub>2</sub> display shows the current CO<sub>2</sub> value.

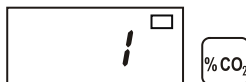

#### NOTE – Factory presetting

Upon delivery of the device, the following nominal values have been set:

- Temperature: 37 °C
- CO<sub>2</sub> content: 0.0 %

## 6. Handling and control

### 6.4 Setting the nominal temperature value

#### 1. Display the nominal value:

- ▶ Press the  key.
- The temperature display shows the current **nominal value**.

#### 2. Enter the nominal value:

The nominal value can be increased or reduced in increments; if you keep the key depressed, the UP/DOWN function switches to a rapid increase/reduction; after approx. 3 seconds, another increase/reduction occurs.

To increase the nominal value:

- ▶ Press the  +  keys.

To reduce the nominal value:

- ▶ Press the  +  keys.

#### 3. Accept and store the nominal value:

- ▶ Release both keys.
- The temperature display shows the **current actual value** measured in the work space.



### 6.5 Setting the CO<sub>2</sub> nominal value

#### 1. Indicate the nominal value:

- ▶ Press the  key.
- The CO<sub>2</sub> display shows the current **nominal value**.

#### 2. Enter the nominal value:

The nominal value can be increased or reduced in increments; if you keep the key depressed, the UP/DOWN function switches to a rapid increase/reduction; after approx. 3 seconds, another increase/reduction occurs.

- ▶ Press the  +  keys.

To reduce the nominal value:

- ▶ Press the  +  keys.

**3. Accept and store the nominal value:**

- ▶ Release both keys.
- The CO<sub>2</sub> display shows the current **nominal value** measured in the work space.

**6.6 Activating the stacked incubator mode**

When stacking the incubators, the stacked incubator mode must be activated on the upper unit. This function adjusts the parameters of the upper unit to compensate any heat transmission between the two units.

**1. Activate the stacked incubator mode:**

- ▶ Keep the  key depressed for 5 seconds, then release key.
- All indicators on the operating panel flash.

**2. Display the mode:**

- ▶ Press the  key.
- The temperature display shows the current mode (disabled).



**3. Change the mode:**

Use the following key combinations to switch between the two modes (enabled and disabled):

- ▶ Press the  +  keys.

or

- ▶ Press the  +  keys.

- The temperature display shows the new mode (enabled).

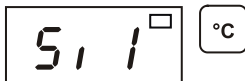

## 6. Handling and control

### 4. Accept and store the desired mode:

- ▶ Press the  key.
- The temperature, O<sub>2</sub>, and CO<sub>2</sub> displays show the actual values.

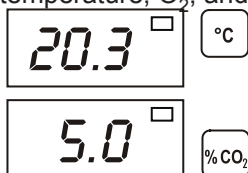

- The new mode is accepted.

### 6.7 Activating the auto-start routine

The auto-start function is an automated routine for the start and the subsequent adjustment of the CO<sub>2</sub> measuring system. After the start, the device control adjusts the temperature to the set nominal value while humidity is generated. When temperature and relative humidity have reached constant values, the CO<sub>2</sub> measuring system is automatically adjusted to these values, and the work space is supplied with the preset quantity of CO<sub>2</sub>.



#### NOTE – Application of the routine

To ensure that the specified accuracy of the CO<sub>2</sub> measuring system is maintained, the device should always be started using the auto-start routine after the nominal temperature setting has been changed by more than 1 °C or after extended interruptions of the operation of the device. The auto-start routine should be run at least every three months on the occasion of cleaning and maintenance works.

Running the routine usually takes 5 to 7 hours. At low room temperatures and when the device is cold, it may take up to 10 hours until the auto-start routine has been completed. If the glass door is opened or if the power supply of the device is interrupted while the routine is running, the routine is interrupted and rerun after the glass door has been closed and after the power supply has been reestablished.

At the start of the auto-start routine, the work space atmosphere must consist only of ambient air. The floor pan must be filled with a sufficient quantity of water!

**1. Open both doors until the acoustic alarm sounds after 30 seconds:**

- All current **actual values** flash on the displays, the "door" LED illuminates, after 30 seconds the acoustic alarm sounds.

**2. Enter nominal values:**

- ▶ See sections 6.4 / 6.5.

**3. Activate the auto-start routine:**

- ▶ Keep the  key depressed for 5 seconds.
- The "auto-start" LED flashes.

**4. Close all device doors:**

- The temperature display shows the actual value, the CO<sub>2</sub> display shows "run", the "door" LED goes off.

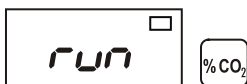
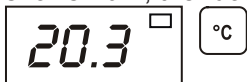

**5. Cancel the auto-start routine:**

- ▶ Keep the  depressed for 5 seconds.
- The displays return to normal operation (incubation operation).



**NOTE – Cancelling the routine!**

**The auto-start routine can be cancelled any time.**



**NOTE – Failure code**

**The cancelling of the routine is indicated by a corresponding failure code. For a list and for a description of the codes, please refer to Section 6.8, "Failure code list".**

## 6. Handling and control

### 6.8 Reading failure codes

The device is equipped with a failure diagnostic system. This system recognizes failures during the operation and allows the allocation of failure causes by numeric codes. Failure recognition is displayed by an acoustic and a visual alarm at the operating panel. The diagnostic system stores the last 10 failures in the sequence of their occurrence. The failure table can be requested and read. If the cause of a failure cannot be repaired, please have the fault code and the serial number of the device available when contacting Technical Service.



#### NOTE – Response delay

**To prevent short term changes of the operating conditions from resulting in repeated failure messages during the operation of the incubator, the diagnostic system has a response delay:**

- **After changes to nominal values:**  
max. 152 min
- **After the glass door has been opened:**  
max. 45 min
- **Other failure causes:** max. 1 min



#### NOTE – Delay time reset

**If the set nominal value is reached during the specified period, the delay time is reset to 1 min.**



#### NOTE – Failure cause

**When the temperature nominal value and/or the CO<sub>2</sub> nominal value is reduced, a failure message (code 101/201) may appear due to the slow reaction time of the atmosphere within the work space. Therefore, the device doors should be opened for some time if the nominal values are reduced.**

6.

Handling and control

1. The audible alarm sounds.

2. Silence the audible alarm:

- ▶ Press any key.
- The audible alarm is silenced.

3. Read failure codes:

- ▶ Keep the  key depressed.
- If no failure is detected, each display shows three hyphens.

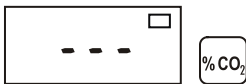
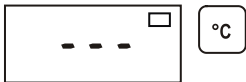

- If the system detects a failure, the display that is assigned to the corresponding control circuit shows a failure code. Example: If the temperature display shows failure code 101, a failure in the temperature control circuit was detected.

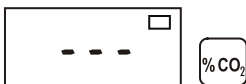



**NOTE – Failure codes**

**For a list and a description of the failure codes, please refer to Section 6.8, "Failure code list".**

## 6. Handling and control

### 5. Scroll through the failure code table:

To read stored failure codes from the failure code table:

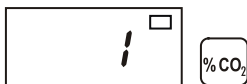
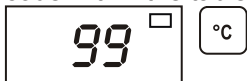

- ▶ Keep the  key depressed.
- ▶ To scroll, keep the  or  key depressed.
- The temperature display shows the last 10 failure codes that had been registered. The CO<sub>2</sub> display shows the number of the individual failure code within the table.



### 6. Exit the failure code table:

- ▶ Release the  key.
- The temperature and CO<sub>2</sub> displays show the current actual values.

### 7. Erase the failure code table:

- ▶ Keep the  +  depressed for 5 seconds.
- The temperature and CO<sub>2</sub> displays flash to indicate that the failure table has been erased.



## 6. Handling and control

### 6.9 Failure code list

Code	Description	Cause	Repair
☰☰☰	No values displayed	Communication between display and CPU- main board faulty	Contact Service
42	NV RAM read failure	NV RAM faulty, default values loaded	Contact Service
43	NV RAM read failure	NV RAM faulty, mirrored values loaded	Contact Service
44	NV RAM faulty	CO <sub>2</sub> measuring cell values not overwritten, device works with default values	Contact Service
54	Manipulated variable failure	Calculation error, device performed RESET	Contact Service
55	I <sup>2</sup> C bus failure	Data transfer faulty, measured value quality dropped below 50 %	Eliminate source of interference, e.g. cellular phone
66	Deviation of temperature sensors from one another	Temperature signal plausibility doubtful	Contact Service
77	CO <sub>2</sub> cal range exceeded	Max. adjustment value exceeded	Contact Service
88	Failure upon auto-start	Total time elapsed or max. adjustment value exceeded	Repeat auto-start
99	Device doors open	Doors open for more than 10 minutes, door switch	Close device doors, test door switch for correct function
100	Temperature below nominal value	Actual value < nominal value -1 °C	Contact Service
101	Temperature above nominal value	Actual value > nominal value +1 °C	Do not exceed ambient temperature limit
104	Temperature sensor faulty	Sensor circuit open/shorted	Contact Service
200	CO <sub>2</sub> below nominal value	Act. val. < nom. val. -1 % • No CO <sub>2</sub> • Prepressure low • Supply line blocked	Check gas supply: • Connect new gas cylinder • Raise prepressure to 1 bar • Check supply line to device
201	CO <sub>2</sub> above nominal value	Act. val. > nom. val. +1 % • Prepressure high	Check gas supply: • Reduce prepressure to 1 bar
204	CO <sub>2</sub> measuring cell faulty	Sensor circuit open/shorted	Contact Service

## 6. Handling and control

### 6.10 Resetting the thermal protection

1. The “Thermal Protection Active” LED illuminates.

2. Turn the device off:

▶ Press the power switch.

○ All indicators come off.

3. Turn the device back on:

▶ Press the power switch.



#### NOTE – Thermal protection

When the cause of the failure (e.g. excessive temperature in the operating room) has been repaired, the device is set to normal incubation operation after it has been turned on again. If the cause of the failure cannot be repaired with simple measures (e.g. by ventilating the room or by reducing the temperature in the operating room), the thermal protection will respond again immediately; in this case, contact Technical Service.

## 7.1 Preparing the device

The device must only be released for operation after all major measures for the start-up have been taken (Section 5.1–5.7).

Prior to starting operation, the following device components must be checked for their correct function:

- Gas hoses must be seated tight on the connecting filter and must be secured using a hose clamp.
- The access port must be capped.
- The pressure compensation opening must be permeable, its insert must be installed in the work space.
- The glass door seal must not be damaged.
- The glass door measurement opening must be capped.
- The shelf system components must be installed safely.



### NOTE – Hygiene regulations

**Prior to any operation, the user must clean and disinfect the work space in accordance with the hygiene regulations set forth by the operator to protect the cultures.**

**The "Principles of good microbiological practice" at the end of these instructions are to be used as safety information for personnel operating the device.**



### NOTE – Water supply

**The water tray of the work space can hold up to 3.0 l of processed water. When the running operation, always keep a sufficient quantity of processed water of the following quality available:**

- **demineralized and distilled or autoclaved for sterilization,**
- or**
- **completely deionized and distilled or autoclaved for sterilization.**

**When the water level falls below the lower limit, refill water.**

## 7.2 Starting operation

### Starting and loading the device:

1. Fill the water tray with up to max. 3.0 l of processed water. Do not exceed the upper level mark.
2. Make sure that the CO<sub>2</sub> supply system valve is open.
3. Turn the device on using the power switch.
4. Set nominal values for temperature and CO<sub>2</sub> content on the operating panel.
5. Ventilate work space by leaving both device doors open until acoustic alarm sounds.
6. Start device using auto-start routine.
7. Close device doors.
8. The temperature control adjusts the temperature to the set nominal value, the humidity rises.
9. When the temperature and relative humidity are constant, automatic adjustment of the CO<sub>2</sub> measuring system is performed.
10. The "auto-start" indicator goes off.
11. The CO<sub>2</sub> control supplies the set amount of CO<sub>2</sub>.
12. The device is ready for operation.
13. Load work space with cultures.



#### **NOTE – Duration of the auto-start routine**

**When the device is cold and when the ambient temperature is low, the auto-start routine may take up to 10 hours.**



#### **NOTE – Loading**

**To ensure sufficient air circulation and even heating of the samples, the loading surface within the work space should be used up to 70 % max. Large objects in the work space that dissipate heat may impair heat distribution.**

### 8.1 Shutting the device down



**CAUTION! – Contamination hazard!**

**If the work space surfaces are contaminated, germs may be transferred to the environment of the device.**

**In case of a shut-down, the device must be decontaminated!**

1. Remove culture containers and all accessories from the work space.
2. Pump water out of the water reservoir.
3. Clean and decontaminate the work space and wipe device dry.
4. Turn device off using the power switch.
5. Unplug power connector and protect it against accidental reconnection.
6. Close the CO<sub>2</sub> supply system shut-off valves.
7. Disconnect gas pressure hoses from sleeve at the rear of the device.
8. Until the device is shut down, the work space must be continuously ventilated: Leave the glass door and the outer door open and secure them in this state.

## 9. Cleaning and disinfection

### 9.1 Cleaning



**CAUTION – Incompatible cleaning agents!**



**Parts of the device are made of plastics. Solvents can dissolve plastics. Strong acids or alkalis can cause embrittlement of the plastics. Do not use solvents containing hydrocarbons, solvents containing more than 10 % alcohol and strong acids or alkalis to clean the plastic parts and surfaces!**

**Moisture-sensitive components!  
Do not spray detergent on the display and the control box on the back of the appliance. When washing, make sure that no moisture penetrates into these components.**

#### **Cleaning the outer surfaces:**

1. Thoroughly remove dirt and debris with lukewarm water mixed with commercial detergent.
2. Wipe surfaces clean using a clean cloth and plenty of clean water.
3. Wipe accessories thoroughly dry.

#### **Cleaning the display:**



**CAUTION – Moisture-sensitive display!**

**Do not wipe the display with a damp cloth or spray with cleaning agent!  
Wipe the display dry with a 100 % microfiber cloth.**

### 9.2 Decontamination procedures

The operator must prepare hygiene regulations for the decontamination of the device in accordance with the application of the device.

**Wipe/spray disinfection:** is used as the standardized manual disinfection procedure for the device and for all accessories.

### 9.3 Wipe/Spray disinfection

The wipe/spray disinfection is carried out in three stages:

- Predisinfection,
- cleaning,

- final disinfection.

Recommended cleaning and disinfection agents:



**CAUTION – Incompatible cleaning agents!**



Some device components are made of plastic. Solvents may dissolve plastics. Powerful acids or bases may cause embrittlement of the plastics.

For cleaning the plastic components and surfaces, do not use hydrocarbon-containing solvents, detergents with an alcohol content of more than 10 % or powerful acids and bases!



**CAUTION – Chloride-containing disinfectants!**



Chloride-containing disinfectants may corrode stainless steel.

Use only disinfectants that do not affect stainless steel!



**CAUTION – Alcoholic disinfectants!**



Disinfectants with an alcohol content of more than 10 % may form, in combination with air, easily combustible and explosive gas mixtures.

When using such disinfectants, avoid open flames or exposure to excessive heat during the entire disinfection process!

- Use such disinfectants only in adequately ventilated rooms.
- After the disinfectant has been allowed to react, wipe the cleaned device components thoroughly dry.
- Observe safety regulations to avoid fire and/or explosion hazard caused by alcohol-containing disinfectants.

**Recommendation disinfectant:**

A surface disinfectant recommended by Thermo Electron LED GmbH is available under the following order number:

- Spray bottle, 250 ml                      Order no.: 50052425
- Refill bottle, 500 ml                      Order no.: 50051939



**NOTE – Description Disinfectant**

Details on efficacy and approval are as follows available on request.

## 9.

## Cleaning and disinfection

Preparing the manual wipe/spray disinfection:



**WARNING – Electric shock!**



Contact with current-carrying components may cause a lethal electric shock.

Prior to cleaning and disinfection work, disconnect the device from the power supply!

- Turn the device off using the power switch.
- Unplug power connector and protect it against accidental reconnection.
- Check to see if the device is deenergized.



**CAUTION! – Health hazard!**



The surfaces of the work space may be contaminated. Contact with contaminated cleaning liquids may cause infections.

Disinfectants may contain harmful substances.



When cleaning and disinfecting, always observe the safety instructions and hygiene regulations!

- Wear safety gloves.
- Wear safety glasses.
- Wear mouth and respiratory system protection gear to protect the mucous membranes.
- Observe the safety instructions of the manufacturer of the disinfectant and of the hygiene experts.

**Pumping water out of the water tray:**

The standard equipment of the device comprises an electrical suction pump for removing the water from the water tray.

1. Attach pump to work space rear panel using the three suction cups with the suction opening of the pump facing downward.
2. Insert pump drain hose into an appropriate reservoir.
3. Connect pump power cable connector to a properly grounded and fused socket.
4. Pump water out of water tray.
5. Disconnect connector from socket and remove pump from rear panel.



## 9. Cleaning and disinfection

- Wipe remaining water off using a cloth.

### Predisinfection:

- Remove all samples from the work space and store them in a safe place.
- Spray disinfectant onto the surfaces of the work space and of the accessories or wipe the surfaces clean using disinfectant.
- Allow disinfectant to react as specified by the manufacturer.



### NOTE – CO<sub>2</sub> sensor

**Do not spray disinfectant onto the CO<sub>2</sub> sensor in the baseplate of the measuring cell.**

### Removing accessories and shelf system:

- Remove all shelves, then remove the entire shelf system from the work space.  
For removal and installation of the shelf system, please refer to Section 5.3.
- If required, remove the blower wheel and its cover from the baseplate of the measuring cell. The wheel and the cover can be autoclaved.

### Removing blower wheel and cover:

- Fig. 20:** Remove the two retaining screws [3] of the cover using the supplied Allen wrench (3 mm) and remove the cover.
- The blower wheel [1] is secured to the axle by a set screw [2]. Remove set screw using the Allen wrench (2 mm) and pull blower wheel off.



### NOTE – Functional check

**After the installation, check to see if the blower wheel is securely attached to the axle and if it can rotate freely, then secure cover using the screws.**

### Cleaning the work space and accessories:

- Thoroughly remove dirt residues and deposits using a solution of tepid water and dishwashing agent.
- Wipe surfaces clean using a clean cloth and plenty of clean water.
- Remove cleaning liquid from water tray and wipe all surfaces of the work space thoroughly dry.
- Wipe accessories thoroughly dry.

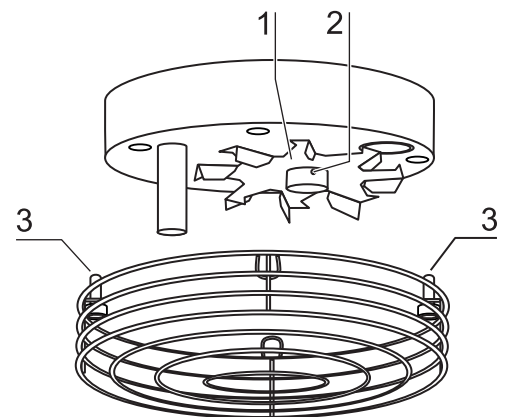

Fig. 20  
Removing blower wheel  
and cover

9.

## Cleaning and disinfection

**Final disinfection:**

1. Install shelf system and accessories.
2. Again, spray disinfectant onto the surfaces of the work space and of the accessories or wipe the surfaces clean using disinfectant.
3. Allow disinfectant to react as specified by manufacturer.

### 10.1 Inspections and checks

To ensure the operativeness and the operational safety of the device, the functions and device components listed below must be checked at different intervals.

**Daily check:**

- Gas supply of the CO<sub>2</sub> supply system.

**Annual inspection:**

- Tightness of the glass door seal.
- Permeability of the pressure compensation opening with insert.
- Functional check of the operating panel and of the device control.
- Electrical safety check in accordance with the relevant national regulations.



**NOTE – Functional check**

**If safety devices were removed or disabled for inspections, the device must not be operated before the safety devices have been reinstalled and checked for their correct function.**

### 10.2 Service intervals

During normal operation, the following service routine must be performed:

**Weekly service:**

- Refill the work space water tray with fresh processed water.

**3-month service:**

- Run auto-start routine.
- Perform temperature and CO<sub>2</sub> calibration.

**Annual service:**

- Replace sterile filter.



**NOTE – Service contract**

**Thermo Electron LED GmbH offers a device-specific service contact that comprises all test and service works required.**

### 10.3 Preparing the temperature calibration

To determine the exact measured value of the integrated temperature sensor, a temperature comparison measurement has to be performed every three months.

If a major temperature deviation is found during this check, a temperature calibration is required.

During this process, the temperature control of the device is set to the value measured during the temperature comparison measurement.

Use a calibrated measuring instrument with an accuracy of  $\leq \pm 0.1 \text{ }^\circ\text{C}$  for this test. To minimize temporary temperature fluctuations during the measurement, the measuring instrument is placed into the work space in an isothermal container (e.g. a bowl filled with glycerol). The center of the work space is the reference location for the comparison measurement.



#### NOTE – Isothermal container

**Do not use a container filled with water as an isothermal container as the evaporation of water will result in a lower temperature reading.**

#### Comparison measurement procedure:

1. Turn device on using power switch.
2. Set temperature nominal value and allow device to be heated. This may take up to several hours.
3. **Fig. 21:** Place measuring instrument [3] onto the center area of the work space.  
Alternatively, a temperature sensor may be positioned in this location. Route the connecting cable either through the measurement opening [2] in the glass door or through the access port [1] at the rear panel of the device.
4. Close doors.
5. Wait until the temperature value displayed on the measuring instrument has stabilized.
6. Calibrate temperature control as described in Section 10.4.

#### Measurement example:

- Temperature nominal value: 37 °C
- Reference temperature: 36.4 °C



#### NOTE – Excessive work space temperature

**Excessive work space temperature after the calibration can be reduced by leaving the doors open for approx. 30 seconds.**

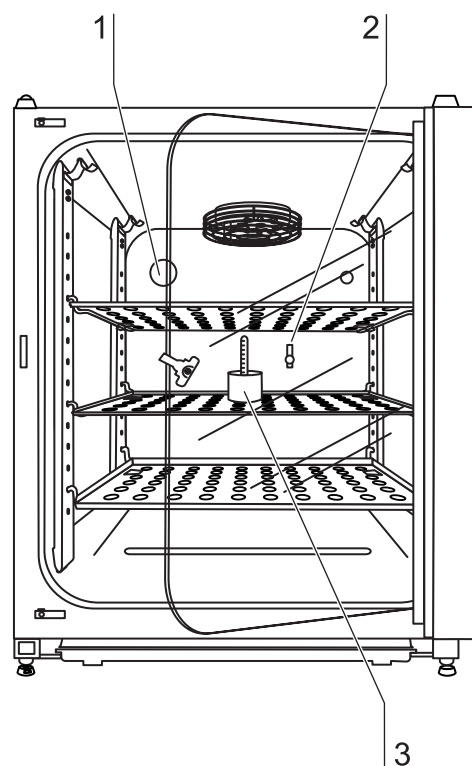



Fig. 21  
Temperature calibration

## 10.4 Temperature calibration procedure

### 1. Activate calibration:

- ▶ Keep the  key depressed for 5 seconds.
- All operating panel indicators flash.

### 2. Display the nominal value:

- ▶ Press the  key.
- The preset value of 37 °C is displayed.



### 3. Enter the measured value (destination value):

- ▶ Press the  +  keys.

or

- ▶ Press the  +  keys.

- Destination value e.g. 36.4 °C

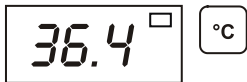

### 4. Accept the destination value:

- ▶ Press the  key.
- The temperature display momentarily shows "CAL",



- then the corrected actual value (measured destination value 36.4 °C) is displayed.

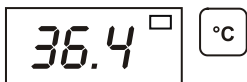

### 5. Cancel the calibration process:

- ▶ Press any key.
- The temperature display and the CO<sub>2</sub> display show the actual values.

### 10.5 Preparing the CO<sub>2</sub> calibration

To determine the exact measured value of the device-integral CO<sub>2</sub> sensor, a CO<sub>2</sub> comparison measurement may be performed every three months.

If a major deviation is found during this check, a CO<sub>2</sub> calibration is required.

During this process, the CO<sub>2</sub> control of the device is set to the value measured during the comparison measurement.

Use a calibrated measuring instrument with an accuracy of  $\leq \pm 0.3\%$  CO<sub>2</sub> for this test.

Suitable instrument:

- Portable IR readout instrument. (Part no. see Section 11, "Spare parts and accessories")

The measuring sample is withdrawn through the sealable measurement opening of the glass door. The comparison measurement must be performed when the device is completely stable.

#### Comparison measurement procedure:

1. Turn device on using power switch.
2. Set CO<sub>2</sub> nominal value and allow device to heat up completely and to create humidity. This process may take several hours.
3. **Fig. 21:** Insert the measuring instrument probe through the measurement opening [1] into the work space. Wait until the CO<sub>2</sub> value displayed by the instrument has stabilized.
4. Remove measuring probe, plug measurement opening and close doors.
5. Calibrate CO<sub>2</sub> control as described in Section 10.6.

#### Measurement example:

- CO<sub>2</sub> nominal value: 5 %
- Measured value: 5.6 %



#### NOTE – Excessive CO<sub>2</sub> content

**Excessive CO<sub>2</sub> content after the calibration can be reduced by leaving the device doors open for approx. 30 seconds.**

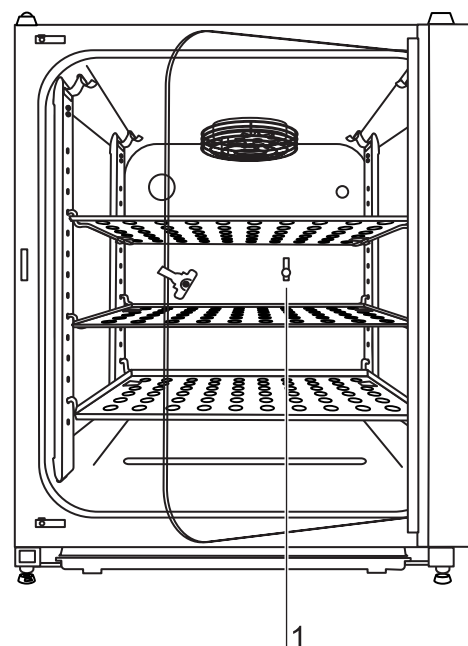



Fig. 21  
CO<sub>2</sub> calibration

## 10.6 CO<sub>2</sub> calibration procedure

### 1. Activate the calibration:



- ▶ Keep the  key depressed for 5 seconds.
- All operating panel indicators flash.

### 2. Display the nominal value:

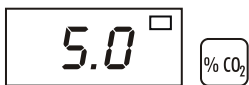

- ▶ Press the  key.
- The set nominal value of 5 % is displayed.



### 3. Enter the measured value (destination value):

- ▶ Press the  +  keys.

or

- ▶ Press the  +  keys.

- Destination value e.g. 5.6 %.

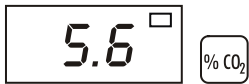

### 4. Accept the destination value:

- ▶ Press the  key.
- The CO<sub>2</sub> display momentarily shows "CAL",



- then the corrected actual value (measured destination value 5.6 %) is displayed.

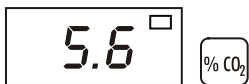

### 5. Cancel the calibration process:

- ▶ Press any key.
- The temperature display and the CO<sub>2</sub> display show the actual values.

## 10.

## Maintenance

## 10.7 Replacing the sterile filters

The sterile filters have plastic threads and are screwed by hand into the threaded hole on the control box.

**Procedure for gas supply sterile filter:**

1. Make sure that the gas supply is shut off.
2. **Fig. 23:** Loosen hose clamp [4].
3. Remove gas hose [5] from sterile filter sleeve [2].

**Procedure for all sterile filters:**

4. Remove retainer [1].
5. Unscrew sterile filter [2] from the threaded hole [3].
6. When installing the new sterile filter, make sure that the plastic thread is not canted. Screw filter in carefully all the way to the stop.
7. Install retainer [1].

**Procedure for gas supply sterile filter:**

8. Connect gas hose to sterile filter sleeve and secure it using hose clamp. Check to see if the gas hose is securely seated on the sleeve.

## 10.8 Replacing the device fuses

**Fig. 24:** The two identical device fuses [4] are installed in the fuse compartment [1] next to the power plug receptacle of the device:

- Time delay fuses, 6.3 A (5x20 mm)

1. The fuse holder is secured to the fuse compartment [1] using two locking tabs [2].
2. To remove the fuse holder, squeeze the two locking tabs and pull holder [3] out of fuse compartment.
3. Remove faulty fuse from holder and install new fuse.
4. Slide fuse holder into fuse compartment and press holder on until locking tabs are fully engaged.

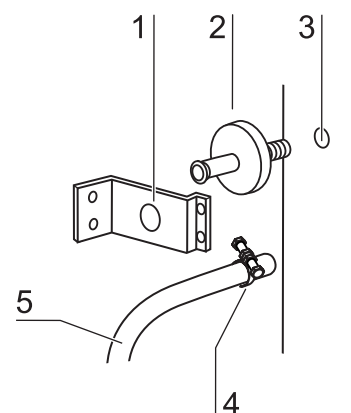

Fig. 23  
Sterile filter replacement

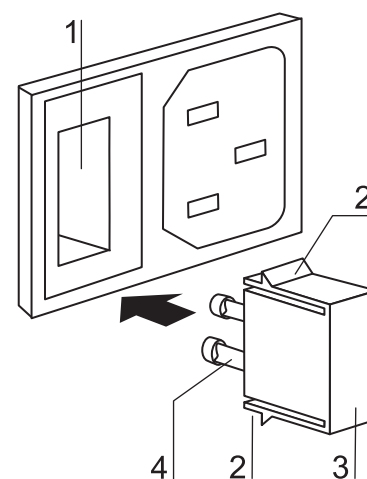

Fig. 24  
Device fuse replacement



### 10.9 Replacing the door seal

The door seal (magnetic seal) of the outer door is located in the retaining slot. No tools are required to replace the seal.

1. **Fig. 25:** Pull magnetic seal [3] out of the guide slot [1].
2. Position new seal at a corner [2] and press seal retaining rail [4] into slot.
3. Make sure that the retaining rail taper is positioned correctly in the slot [1] and that the seal is flush with the door frame.

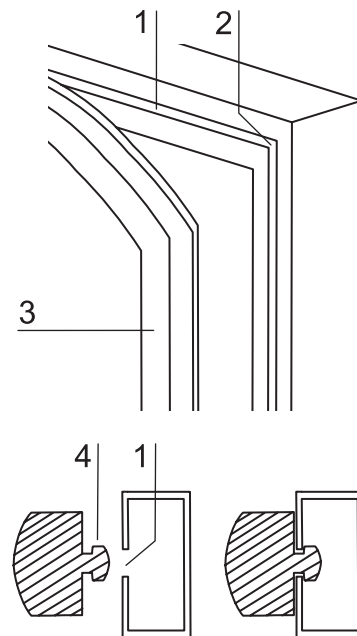

Fig. 25  
Door seal replacement

## 11.

## Spare parts and accessories

## 11.1 List of spare parts and accessories

When ordering spare parts, please have the device specifications on the nameplate available.

**NOTE – Repairs**

**Use only original spare parts that have been tested and approved by Thermo Electron LED GmbH. The use of other spare parts presents potential hazards and will make the warranty void.**

Description	Type	Part No.
Operating instructions	Set	50078936
Stacking element	Ceiling, set of 3	50049238
Stand	Height-adjustable	50049939
Floor stand	Height 200 mm	50051376
Floor stand with rollers	Height 185 mm	50057161
Floor stand	Height 780 mm	50051436
Roller set for floor stand, set of 4	Guide rollers	50052528
Spare caps	Set	50052958
Outer door magnetic seal	637 x 858	50078769
Glass door silicone seal		50048705
Glass door	Complete	50050779
Glass door latch	Complete	50058542
Shelf, set with 2 shelf supports	Stainless steel	50051909
Split shelf, set with 2 shelf supports	Copper	50052454
Support rail, front	Stainless steel	50050923
Support rail, rear	Stainless steel	50050924
Support rail, front	Copper	50051420
Support rail, rear	Copper	50051421
Spring for support rail		50050922
HERAtray 1/3 width, set of 3	Stainless steel	50051913
HERAtray 1/3 width, set of 3	Copper	50051914
HERAtray, 1/2 width, set of 2	Stainless steel	50058672
HERAtray, 1/2 width, set of 2	Copper	50061050
Electrical suction pump	230 V	50051461
Electrical suction pump	120 V	50051937
Blower wheel	Stainless steel	50049692
Blower wheel	Copper	50051184
Device fuse	T 6.3 A (set of 2)	3002641

Description	Type	Part No.
Power supply cable	EU	50043143
Power supply cable	GB	50047100
Power supply cable	IT	50047101
Power supply cable	CH	50047099
Power supply cable	120 V, USA	50048111
Hose set for gas connection		50062701
Sterile filter, gas inlet	With thread	50050737
Cylinder pressure reducer CO <sub>2</sub>	Dual-stage	3429937
Measurement opening plug		26139262
Insert for pressure compensation opening		50070316
Plug for pipe channel		50063283
IR CO <sub>2</sub> gas tester (Incl. Charger)	100 V – 230 V	50060283
Spare filters, set of 5, for IR CO <sub>2</sub> gas tester		50060287
IrDa computer interface with connecting cable and PM COM software		50060289
CO <sub>2</sub> gas tester with 10 test tubes	Measurement kit	50051 435
CO <sub>2</sub> test tubes, set of 10	0 ... 10 % vol.	50055124
Surface disinfectant, 250 ml, spray bottle	Barrycidal 36	50052425
Surface disinfectant, 500 ml, refill bottle	Barrycidal 36	50051939
Gas cylinder monitor GM 2	EU	50046033
Gas cylinder monitor GM 2	GB	50054748
Gas cylinder monitor GM 2	USA	50059043
Adapter plate for stacking 2 BB 15		50079816
Door handle		50079817

**12.**
**Technical data**

Description	Unit	Value
<b>Mechanical</b>		
External dimensions (W x H x T)	mm	637 x 870 x 766
Interior dimensions (W x H x T)	mm	470 x 607 x 530
Chamber volume	l	approx. 151
Shelves (W x T)	mm	423 x 455
Standard quantity	Piece	3
Maximum quantity	Piece	10
Maximum surface load	kg	10 / insertion shelf
Maximum device overall load	kg	30
Weight, without accessories	kg	60 (stainless steel)
<b>Thermal</b>		
Ambient temperature range	°C	+18...33
Temperature control range	°C	RT + 3 ... 55
Temperature deviation, time (DIN 12880, Part 2)	°C	± 0.1
Temperature deviation, spatial (DIN 12880, Part 2) at 37 °C	°C	± 0.5
Duration of the auto-start routine, to 37 °C ambient temperature 20 °C	h	5 ... 10
Temperature recovery time, at 37 °C, door open 30 seconds (to 98 % of initial value)	min	< 10
Heat transfer to environment at 37 °C	kWh/h	0.085
<b>Humidity</b>		
Water quality		Electrical Resistance: 50 KΩcm to MΩcm Conductivity: 1 to 20 μS/cm
Liquid quantity incubation operation	l	max. 3.0 / min 1.2
Constant humidity at 37 °C	% rH	approx. 95
Humidity recovery time, at 95 % rH, door open 30 s (to 98 % of initial value)	min min	approx. 30 (stainless steel) approx. 30 (copper)
<b>CO<sub>2</sub> gas supply system</b>		
Gas purity	%	min. 99.5 or medical quality
Prepressure	bar	min. 0.8 - max. 1
Measuring and control range	% vol.	0... 20
Control deviation, temporal	% vol.	± 0.1
Recovery time, at 5 %, door open 30 seconds (to 98 % of initial value)	min	< 8

Description	Unit	Value
<b>CO<sub>2</sub> measuring cell</b>		
Accuracy (absolute)	% CO <sub>2</sub>	± 0.3
<b>Electrical system</b>		
Rated voltage	V V	1/N/PE 230 V, AC 1/N/PE 120 V, AC
Rated frequency	Hz	50/60
Interference suppression (DIN VDE 0875)		Interference level N
Type of protection (DIN 40 050)		IP 20
Protection class		I
Overvoltage category (IEC 1010, EN 61010)		II
Pollution severity (IEC 1010, EN 61010)		2
Rated current	A	2.2 (230 V, AC) 5.0 (120 V, AC)
On-site fusing: Fuse Circuit breaker		T 16 A B 16
Rated input	kW kW	0.52 (230 VAC) 0.60 (120 VAC)
EMC class		B
<b>Others</b>		
Sound pressure level (DIN 45 635, Part 1)	dB(A)	< 50
Relative humidity of environment	% rH	max. 80
Location elevation	m NN	max. 2000

**13. Technical data**

Fig. 26: Overview of gas consumption (CO<sub>2</sub>)

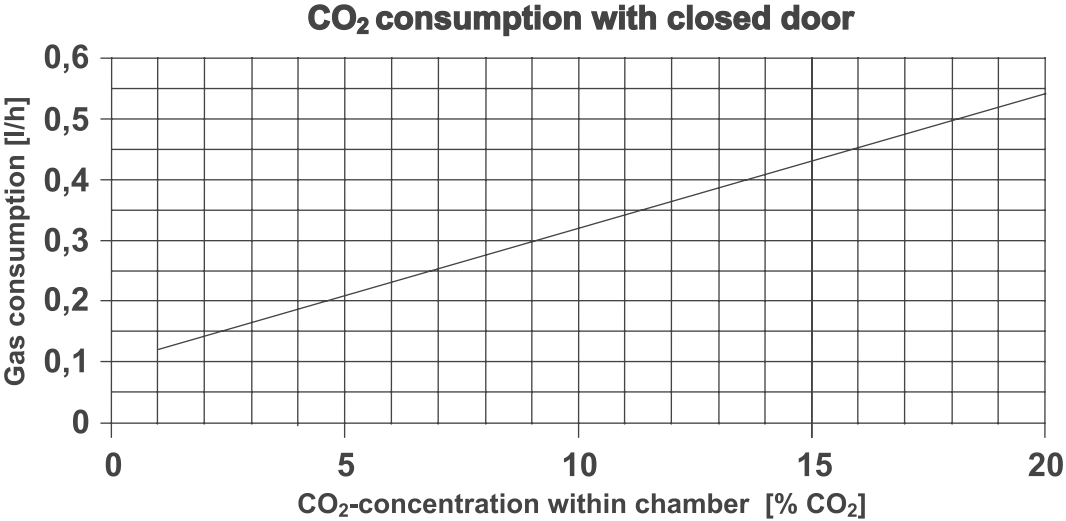

Fig. 26  
Overview of gas  
consumption (CO<sub>2</sub>)



**CAUTION – Contamination hazard!**

The device can be used for preparing and processing infectious substances so that the device or device components may become contaminated.

Before device components are discarded, they must be decontaminated!

- The device components must be cleaned thoroughly; after the cleaning, they must be disinfected or sterilized, as required by the application.
- Discarded devices or device components must be provided with an appropriate certificate showing the decontamination measures performed.

All device components can be discarded properly after they have been decontaminated properly.



**NOTE – Recycling service**

Thermo Electron LED GmbH offer, for a small fee, an environmentally compatible recycling service for discarded devices.

Component	Material
Thermal insulation components	Polystyrene foam EPS/PPS-Compound
Printed circuit boards	Enclosed electrical components coated with different plastics, equipped on epoxy resin-bound boards.
Plastic components, general	Note material labelling
Exterior housing	Galvanized steel sheet, painted
Device rear panel	Galvanized steel sheet
Outer door	Galvanized steel sheet, painted
Door inner panel	Galvanized steel sheet, painted
Operating panel and indicator foil	Polyethylene
Magnetic door seal	Magnetic core sheathed with EMPP
Heating	Silicone-sheathed resistance-type wires
Interior containers, installed components and shelves	Stainless steel 1.4301 or copper
Plug for pipe channel	Silicone
Pressure compensation opening insert	POM with brass sinter filter
Glass screen	Soda-silicate glass
Glass door seal, measurement opening	Tempered silicone

12.

Disposal

Component	Material
Sensor block	Stainless steel 1.4301
Blower wheel	Stainless steel 1.4305 or copper
Measuring cell baseplate seal	Tempered silicone
Cables	Plastic-sheathed copper flexible
Packaging	Corrugated board, polyethylene film, and Styrofoam

**WEEE Compliance:**

This product is required to comply with the European Union`s Waste Electrical & Electronic Equipment (WEEE) Directive 2012/19/EU. It is marked with the following symbol:



Thermo Electron LED GmbH has contracted with one or more recycling/disposal companies in each EU Member State, and this product should be disposed of or recycled through them. Further information on Thermo Electron's compliance with these Directives, the recyclers in your country, and information on Thermo Electron products which may assist the detection of substances subject to the RoHS Directive are available at [www.thermo.com/WEEERoHS](http://www.thermo.com/WEEERoHS).



**General information:**

- Keep windows and doors at the place of location closed while carrying out work.
- Do not eat, drink or smoke in the work area.  
Do not store food in the work area.
- Wear laboratory frocks or other protective clothing in the work area.
- Always use auxiliaries when pipetting.
- Do not use syringes and hollow needles unless absolutely necessary.
- For all manipulations, try to avoid aerosol formation.
- After completion of the work and prior to leaving the work area, wash your hands thoroughly and disinfect and regrease them, as required.
- Keep the work area tidy and clean. The work tables should contain only the required devices and materials. Store stocks only in the designated containers and cabinets.
- Check the identity of the used agents at regular intervals as required for assessing the potential hazard. The intervals depend on the potential hazard.
- When handling agents, employees are subject to a verbal, job-related instruction prior to starting work and subsequently at least once a year.
- Employees with little or no experience in microbiology, virology or cellular biology must be carefully instructed, guided, and looked after.
- Vermin must be exterminated at regular intervals, as required.

**The following additional principles apply to the handling of causatives:**

- Disinfect all workplaces every day. If required, the growth of resistant germs must be prevented by using a different disinfectant.
- Do not wear protective clothing outside the work area.
- Autoclave or disinfect contaminated devices prior to cleaning.
- Germ-contaminated waste must be collected safely and destroyed by autoclaving or disinfecting.
- If infectious material is spilled, the contaminated area must be immediately blocked and disinfected.
- When handling humanopathogenic germs for which an effective vaccine is available, all employees must be vaccinated and immunity has to be checked at regular intervals using appropriate measures.
- The health conditions of the employees must be monitored using occupational medicine check-ups, i.e. initial examination prior to starting work and annual follow-ups. For the check-ups, particularly the guidelines G24, "Skin Diseases", and G42, "Infection Diseases", of the German trade associations apply; these guidelines are used as generally acknowledged occupational medicine guidelines by physicians to rate, evaluate, and acquire examination results based on identical criteria.
- For handling genetically manipulated organisms, viruses, and subviral agents with potential hazards, proceeding according to guideline G43, "Biotechnology", of the German trade associations is required.
- First aid instructions for accidents with pathogenic microorganisms and viruses must always be freely accessible in the work area. All accidents must be reported immediately to the supervisor in charge.

**Further safety measures in dependence of the potential hazard:**

- Usage of safety cabinets (airflow directed away from the experimentator) according to Class I, Class II (type-tested)<sup>2</sup> or Class III.
- Restriction and monitoring of the access to certain areas.
- Usage of special protective clothing and breathing equipment.

## 14.

## Principles of good microbiological practice

- Disinfection of all germ-contaminated materials before they are removed from the worktable.
- Constant vacuum in the work area.
- Reduction of the germ quantity in the exhaust air by suited measures, e.g. HEPA filters.

**The following general directives apply to the handling of humanopathogenic and livestock-pathogenic biological agents:**

- For handling humanopathogenic biological agents, a permission according to the German Federal Epidemic Act is required.
- For the handling of livestock epidemic germs, a permission in accordance with the German Livestock Epidemic Act and Livestock Epidemic Germ Directive is required.
- Pregnant women and breast-feeding mothers must not handle infectious humanopathogenic biological agents or materials containing these agents.

<sup>1</sup>To be applied accordingly to cell cultures.

<sup>2</sup>Manufacturers references are published in the information bulletins "Safe Chemical Working" of the German chemical industries trade association and of the German trade association for health and welfare service and also on demand by the inspection office of the expert commission "Health and Welfare Service". The commission can be contacted at the trade association for health and welfare service, Pappelallee 35-37, D-2000 Hamburg

Reference: Notice B003, Issue 1/92 – ZH 1/343 of the trade association of the German chemical industry, published by Jedermann Verlag, Postfach 103140, D-69021 Heidelberg.



## Certificate of decontamination

Invoice recipient / Customer no.:			Location / Forwarding address:		
Year of manufacturer:	KC:	ST:	Name of technician:	Appointed date:	
order date:	Ordered by:	Order no.:			
Type of device:			ID no. / Order no.:	Operating hours:	
Equipment no.:	Factory no.:	Service device no.:	Date of delivery:	Date of start-up:	Customer inventory no.:

### Certificate of decontamination

Dear customer,

when using biological and chemical agents within and outside of devices, hazards to the health of the operating personnel may be present and contamination of the surroundings of the device may occur when service or repair works are carried out.

Within the scope of national and international legal regulations, such as

- responsibility of a company for the protection of its employees,
- responsibility of the operator for the operational safety of devices,

all possible hazards must absolutely be prevented. Prior to any calibration, service, and repair works, prior to any relocation of a device, and prior to the shut-down of a device, the device must be decontaminated, disinfected, and cleaned as required by the work to be carried out. Therefore, we ask you to fill in this certificate of decontamination before you start with the required work.

Yours sincerely

Thermo Electron LED GmbH

### Works to be carried out (please mark where applicable)

Service	<input type="checkbox"/>	Filter replacement	<input type="checkbox"/>
Repair	<input type="checkbox"/>	Relocation	<input type="checkbox"/>
Calibration	<input type="checkbox"/>	Transport	<input type="checkbox"/>

### Declaration of possible contamination (please mark where applicable)

The device is clear of biological material	<input type="checkbox"/>	The device is clear of dangerous chemical substances	<input type="checkbox"/>
The device is clear of radioactivity	<input type="checkbox"/>	The device is clear of other dangerous substances	<input type="checkbox"/>
The device is clear of cytostatic agents	<input type="checkbox"/>		

### Certification:

Prior to carrying out the required work, we have decontaminated, disinfected, and cleaned the device as described in the operating instructions of the device and in accordance with nationally applicable regulations. The device does not present any hazards.

Note:

Date, legally binding signature, stamp



thermo scientific



Thermo Electron LED GmbH  
Robert-Bosch-Straße 1  
D - 63505 Langenselbold

---

Find out more at [thermofisher.com](https://www.thermofisher.com)

© 2019 Thermo Fisher Scientific Inc. All rights reserved. All trademarks mentioned in this operating instructions are the exclusive property of the respective manufacturers.  
50078936 1019

**ThermoFisher**  
S C I E N T I F I C